

www.wackergroup.com

0109969en	006
09.2008	

Gasoline cut-off saw

BTS

930L3, 935L3, 1030L3, 1035L3, 1140L3



Operator's manual

Important note

EPA engine

This machine is equipped with an EPA-certified engine.

Relevant details can be found in the instructions of the engine manufacturer.

Warning

The engine's exhaust fumes contain chemicals which are known to the State of California to cause cancer, congenital defects or other reproductive anomalies.

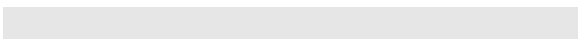

Warranty for machines with EPA-certified engines (USA)

WARRANTY IN CASE OF DEFECTIVE EXHAUST MONITORING DEVICES

The engine manufacturer guarantees the first end user and every subsequent owner that this engine was designed, built and equipped for a machine that is not to be used on the road, that at the time of the initial purchase it met all valid EPA regulations, and that the engine does not have any defects due to material or workmanship such that this engine would not fulfill the requirements of the EPA regulations for the duration of the warranty period.

For the components listed below under PARTS INCLUDED, the authorized WACKER customer service shop will carry out all trouble-shooting, repairs or replacements necessary for the engine to meet the valid EPA regulations.

WARRANTY PERIOD IN CASE OF DEFECTIVE EXHAUST MONITORING DEVICES

The warranty period for this engine begins on the date it is purchased by the first user and ends after 2 years.

PARTS INCLUDED

The parts included in the above warranty are listed below. Regularly scheduled maintenance is required for some of the parts listed. These parts are under warranty only up to the first planned replacement.

Fuel batching system

Carburetor and internal parts

Fuel filter, if present

Throttle flap, if present

Choke system, if present

Air supply system

Air cleaner plate, air cleaner

Air cleaner housing, intake manifold

Ignition system

Spark plugs

Magneto flywheel

Ignition coil

Other parts of the above systems

Fuel hoses, clamps and seals

WARRANTY SERVICES

To use the services within the scope of the warranty, bring the engine to the nearest authorized WACKER customer service shop. Present your purchase receipt, which includes the date of purchase. The authorized WACKER customer service shop will carry out the necessary repairs or conversion within an appropriate period of time and will give you a copy of the repair order. All parts and accessories replaced within the scope of this warranty become the property of WACKER.

WHAT IS NOT INCLUDED?

- * Defects due to unauthorized intervention, improper use or adjustment (except when carried out by an authorized WACKER customer service shop as a warranty repair), modifications, accidents, use of unsuitable fuels and oils or not carrying out prescribed maintenance work.
- * The replacement parts used for prescribed maintenance work.
- * Consequential damage, e. g. loss of time, inconvenience, downtime for engine or machine, etc.
- * Diagnostic or testing fees if the testing reveals that a warranty claim cannot be made.
- * Any of the disallowed parts or breakdowns of allowable parts due to the use of disallowed parts.

RESPONSIBILITIES OF THE OWNER WITHIN THE SCOPE OF THE WARRANTY

As the owner of the engine you are responsible for carrying out the prescribed maintenance in accordance with the operator's manual. WACKER recommends that you retain all documents pertaining to maintenance work on your engine. However, WACKER cannot dismiss warranty claims based only on missing documentation or not carrying out all scheduled maintenance work. However, we draw your attention to the fact that WACKER can dismiss warranty claims if a defect to your engine or to a part of it was caused by improper use, negligence, improper maintenance or impermissible modifications.

You are obliged to bring your engine to the nearest authorized WACKER customer service shop as soon as a problem occurs.

If you have questions regarding your rights and responsibilities within the scope of the warranty, please contact the WACKER CORPORATION Product Support Department (USA: 1-800-770-0957, Canada: 1-877-977-0775).

WHAT YOU SHOULD KNOW ABOUT THE WARRANTY FOR THE EXHAUST CONTROL SYSTEM:

MAINTENANCE AND REPAIRS

You are responsible for properly maintaining your engine. Retain all documents pertaining to regular maintenance work in case there are questions. Give these documents to any subsequent owner of the engine. WACKER reserves the right to dismiss warranty claims if the engine has not been properly maintained. However, warranty claims will not be dismissed only because prescribed maintenance was not carried out or maintenance documents are missing.

MAINTENANCE, REPLACEMENTS OR REPAIRS OF EXHAUST GAS REGULATING DEVICES AND SYSTEMS MAY BE CARRIED OUT BY ANY REPAIR SHOP OR PERSON. HOWEVER, WARRANTY REPAIRS MUST BE CARRIED OUT BY AN AUTHORIZED WACKER CUSTOMER SERVICE SHOP. THE USE OF PARTS THAT ARE NOT EQUIVALENT TO ALLOWABLE PARTS IN TERMS OF PERFORMANCE AND SERVICE LIFE CAN IMPAIR THE EFFECTIVENESS OF THE EXHAUST CONTROL SYSTEM AND VOID A WARRANTY CLAIM.

If parts other than those allowed by WACKER were used for replacements within the scope of maintenance or to repair components related to the exhaust control system, you are responsible for determining if a manufacturer's warranty exists for these parts that is equivalent to that for parts allowed by WACKER in terms of performance and service life.

HOW TO MAKE A WARRANTY CLAIM

All repairs for which a warranty claim can be made within the scope of this limited warranty must be carried out by an authorized WACKER customer service shop. If a fault is detected in a part of the exhaust control system during the warranty period, contact the WACKER CORPORATION Product Support Department (USA: 1-800-770-0957; Canada: 1-877-977-0775). They will let you know which customer service shop or which suitable service station can carry out the warranty repair.

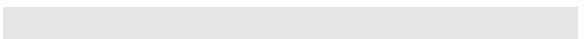

1. Foreword

For your own safety and protection from bodily injuries, carefully read, understand and follow the safety information in this manual.

Please operate and maintain your WACKER machine in accordance with the instructions in this operator's manual. Your WACKER machine will reward you with troublefree operation and a high degree of availability.

Defective components must be replaced immediately.

All rights, especially the right for copying and distribution, are reserved

Copyright 2008 by Wacker Construction Equipment AG

No part of this publication may be reproduced in any form or by any means, electronic or mechanical, including photocopying, without express permission in writing from Wacker Construction Equipment AG.

Any type of reproduction, distribution or saving on data carriers of any type or method not authorized by WACKER represents an infringement of valid copyrights and will be prosecuted. We expressly reserve the right to make technical modifications - even without special notice - which aim at further improving our machines or their safety standards.

Table of contents

1. Foreword	9
2. Many thanks for choosing this product!	12
2.1 Packaging	13
3. Scope of delivery/Symbols	14
3.1 Scope of delivery	14
3.2 Symbols	14
4. Safety information	16
4.1 Proper use	16
4.2 General notes	16
4.3 Personal protective gear	17
4.4 Operating fluids / Filling the tank	20
4.5 Starting up	21
4.6 Cutting blades	22
4.7 Kickback and pulling motion	25
4.8 Work habits and methods	26
4.9 Instructions for using synthetic resin cutting blades	27
4.10 Cutting metals	28
4.11 Cutting stone, concrete, asbestos or asphalt	30
4.12 Transport and storage	32
4.13 Maintenance	33
4.14 First Aid	34
4.15 Disposal and environmental protection	35
5. Technical data	36
6. Part identification	39

7.	Starting up	41
7.1	Attaching the cutting blade	42
7.2	Tightening the V-belt/Checking the tension	43
7.3	Operating fluids	44
7.4	Storing fuel	45
7.5	Filling the tank	46
7.6	Starting the engine	47
7.7	Turning off the engine	49
7.8	Readjusting the idle speed	49
8.	Maintenance work	51
8.1	Replacing the V-belt	52
8.2	Cleaning the protective hood	53
8.3	Cleaning/Changing the air cleaner	53
8.4	Prefilter, air cleaner cartridge and internal filter	55
8.5	Replacing the spark plug	58
8.6	Checking the ignition spark	59
8.7	Replacing the suction head	60
8.8	Replacing the starter rope	60
8.9	Replacing the return spring	62
8.10	Cutting attachment in the center/outer position	63
8.11	Remounting the cutting attachment	64
8.12	Periodic maintenance and service instructions	66
8.13	Troubleshooting	68
9.	Guide cart	69
9.1	Application	69
9.2	Safety information	70
10.	Signs	71
	 EC Declaration of Conformity	 73
	 DIN EN ISO 9001 Certificate	 75

Many thanks for choosing this product!

2. Many thanks for choosing this product!

We're pleased that you decided to purchase your new WACKER cut-off saw. The WACKER cut-off saws are equipped with specially designed high performance engines with an excellent power to weight ratio for better performance at a lower weight.

Other advantages of the WACKER cut-off saw include:

- * Robust construction and high reliability.
- * Maintenance-free electronic ignition, hermetically encapsulated to prevent dust and moisture from entering.
- * Vibration damping with a double-mass system that allows operators to work nearly without fatigue, even with a hand-operated machine.
- * Five stage air cleaner system for reliable operation, even when an unusual amount of dust is produced.
- * Two ways to mount the cutting blade: Use the center position for optimal balance with the hand-operated machine or the side position for cutting near to walls or curbs or for horizontal cuts directly above the ground.
- * A comprehensive range of accessories, including synthetic resin or diamond-encrusted cutting blades and a guide cart, water sprayer and angular fuel tank filler neck.

We'd like you to be happy with your purchase from WACKER. To guarantee that your WACKER cut-off saw is always ready to use and functions well and to ensure your personal safety, we'd like to ask you to:

Read this operator's manual completely before using the cut-off saw for the first time and, above all, follow the safety regulations! Not following the regulations can lead to life-threatening injuries!



Many thanks for choosing this product!

2.1 Packaging

To avoid damage during transportation, your WACKER cut-off saw was shipped in a cardboard box.

Cardboard is a renewable resource and can be used again and or recycled as waste paper.



Scope of delivery/Symbols

3. Scope of delivery/Symbols

3.1 Scope of delivery

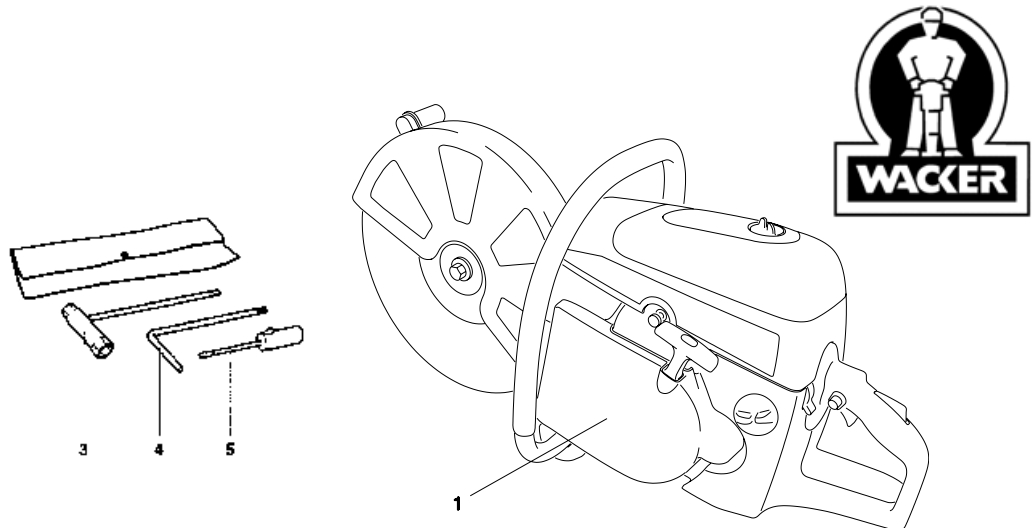





1. Cut-off saw
3. Combination wrench 13/19 mm
4. Offset screwdriver
5. Screwdriver for setting the carburetor
6. Operator's manual (without illustration)





















If any of the components listed here is not included with delivery, please contact your salesperson!

3.2 Symbols

You will find the following symbols on the machine and when reading the operator's manual:

	Read the operator's manual and observe the warnings and safety information		Multifunction switch Start/Stop (I/O), choke
	Use extra caution!		Locked / Unlocked

Scope of delivery/Symbols

	Prohibited!		Wear eye protection!
	Wear a helmet, eye protection, mouth protection and ear protection!		Start the engine
	Wear protective gloves!		Turn off the engine!
	Wear breathing protection!		Caution, kickback!
	No smoking!		Fuel/oil mixture
	No open flames!		First Aid
	Cutting blade's direction of rotation!		Recycling
	Maximum cutting blade peripheral speed is 80 m/s!		CE marking
	Dangerous dust formation and gas emission!		Fire hazard from flying sparks!
	Cutting blade dimensions!		Never use circular saw blades
	Actuate the decompression valve		

Safety information

4. Safety information

4.1 Proper use

Cut-off saw

The cut-off saw must only be used outdoors for cutting/cutting to length suitable materials with the cutting blade approved for the unit.

Non-approved work methods:

The cutting blades of the cut-off saw must not be used as a grinding tool (removing material with the side surface of the cutting blade). This may cause the cutting blade to break! It is prohibited to attach saw blades, knives or brushes to the cut-off saw.

Non-approved operators:

Persons unfamiliar with the operator's manual, children, juveniles as well as persons under the influence of alcohol, drugs or medication must not attempt to operate the unit.

4.2 General notes

- 4.2.1 **To ensure safe handling, the operating person must read the operator's manual (even if that person is experienced in using a cut-off saw), to become familiar with the cut-off saw.** Operators can endanger themselves and others if they are unaware or insufficiently informed about how to properly use the unit.



- 4.2.2 Only lend the cut-off saw to experienced users. Give the operator's manual to the user along with the tool.
- 4.2.3 First time users should receive instruction from a skilled technician regarding the characteristics of engine-driven cutting.
- 4.2.4 Children and juveniles under the age of 18 must not attempt to operate the cut-off saw. Juveniles who are at least 16 years old are exempted from this rule if they are working under the supervision of qualified personnel for educational purposes.
- 4.2.5 Working with the cut-off saw requires special precautions.
- 4.2.6 Work only if you are in good physical condition. Fatigue can lead to carelessness. Take special precautions, particularly as you finish your work. Carry out all work calmly and circumspectly. The operator is responsible for others in the area.

- 4.2.7 Never operate the machine under the influence of alcohol, drugs, medication or other substances that can impair your vision, coordination and judgment.



- 4.2.8 When working with highly flammable vegetation and in dry conditions ensure that a fire extinguisher is readily available for use (danger of fire).
- 4.2.9 Asbestos or materials that could discharge toxins may only be cut using the proper safety measures and after notifying the responsible authorities and under their supervision or that of persons charged with this duty. The use of dust bonding devices is strongly recommended.
- 4.2.10 Some dust created by power sanding, sawing, grinding, drilling, and other construction activities contains chemicals known (to the State of California) to cause cancer, birth defects or other reproductive harm. Some examples of these chemicals are:
- * lead from lead-based paints,
 - * crystalline silica from bricks and cement and other masonry products
 - * arsenic and chromium from chemically treated lumber.

Your risk from these exposures varies, depending on how often you do this type of work.

To reduce your exposure to these chemicals: work in a well ventilated area, and work with approved safety equipment, such as those dust masks that are specially designed to filter out microscopic particles.

4.3 Personal protective gear

- 4.3.1 Wear and use the following protective equipment and devices to prevent head, eye, hand and foot injuries as well as hearing damage.
- 4.3.2 Clothing should be appropriate, i.e. should be close-fitting but not restrict your movement. When cutting metal, do not wear clothing in which grains of material can be caught (pants with cuffs, jackets or pants with open pockets, etc.).
- 4.3.3 Do not wear jewelry or clothing that can become entangled or distract the operator from the cutting process.

Safety information

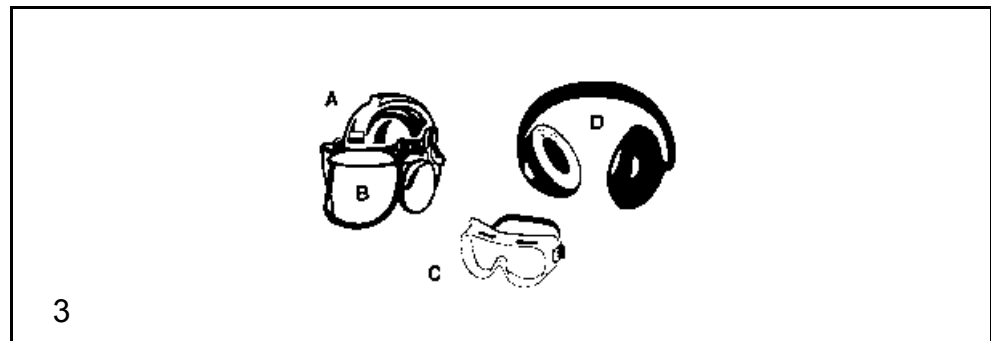

- 4.3.4 Always wear a **hardhat** (A). Regularly check the hardhat for damage and and replace it at least every 5 years. Only use tested hardhats.
- 4.3.5 The hardhat **face protection** (B) protects the face from grinding residue and grains of material. To prevent eye and face injuries, always wear **eye protection** (C) or face protection when working with the cut-off saw.
- 4.3.6 To prevent hearing damage always wear suitable **ear protection**. (Ear protections (D), ear plugs, etc.). Octave band analysis by request.

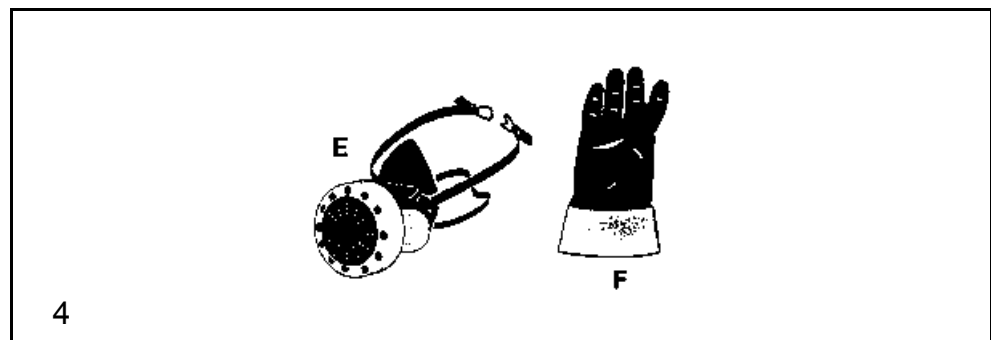

- 4.3.7 When dry cutting stone materials that generate particulate matter (stone, concrete, etc.), properly functioning **breathing protection** (E) must be worn.
- 4.3.8 **Work gloves** (F) made of durable leather are part of the proper working equipment and must always be worn when working with the cut-off saw.

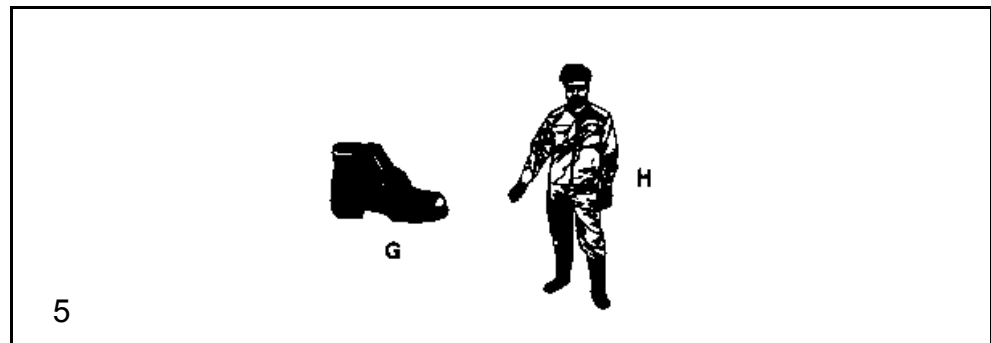

- 4.3.9 Wear non-skid, hard-toed **shoes** or **boots** (G) and leg protection when working with the cut-off saw. Safety shoes with protective inlays protect feet from laceration and ensure that the operator is standing in secure position.
- 4.3.10 Always wear **overalls** (H) made of durable material that is sufficiently fire resistant!

Safety information

4.4 Operating fluids / Filling the tank

- 4.4.1 Before you fill the tank, go to a safe and level area. **It is prohibited to fill the tank on a scaffolding, a mound of material or similar elevated structure!**
- 4.4.2 Turn off the engine before you fill the tank of the cut-off saw.

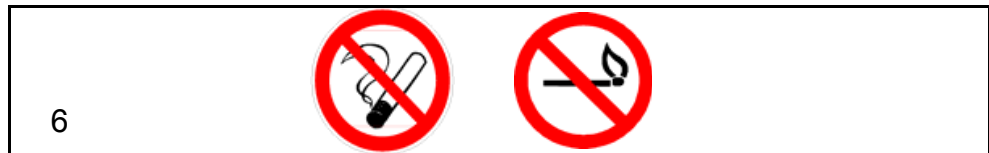

- 4.4.3 Smoking and open fires are not permitted (6).
- 4.4.4 Let the engine cool down before you fill the tank.
- 4.4.5 Fuels can contain solvent-like substances. Avoid skin and eye contact with mineral products. When filling the tank, wear gloves (not work gloves). Change and wash your clothing more often. Do not inhale fuel vapors. Inhaling fuel vapors can damage your health.
- 4.4.6 Do not spill fuel. If you have spilled fuel, clean the cut-off saw immediately. Avoid getting fuel on your clothing. Should you spill fuel on your clothing, change your clothes immediately.
- 4.4.7 Make every effort to ensure that you do not allow fuel to soak into the ground (environmental protection). Use a suitable base.
- 4.4.8 Do not fill the tank in closed rooms. Fuel vapors accumulate near the floor (danger of explosion).
- 4.4.9 Tightly close the screw plug on the fuel tank.

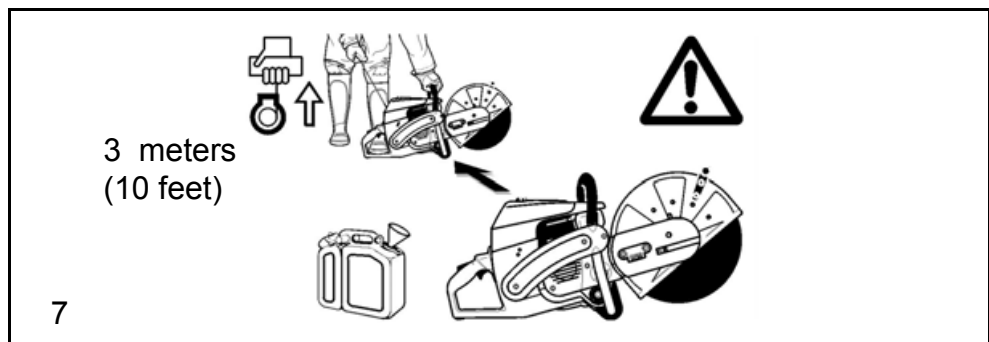

- 4.4.10 To start the cut-off saw, go to another location (at least 3 meters (10 feet) away from the place where you filled the tank) (7), however not in the extended swing area (direction of flying sparks) of the cutting blade.
- 4.4.11 Fuels cannot be stored indefinitely. Purchase only enough fuel as you can possibly use in the foreseeable future.
- 4.4.12 Only use fuel and oil which has been approved by WACKER, see chapter *Technical Data*.

Safety information

- 4.4.13 When preparing the correct gasoline/oil mixing ratio, first always pour oil into the mixing container and then the gasoline.
- 4.4.14 Transport and store fuel only in approved and specially marked canisters.
Do not allow children near the fuel.

4.5 Starting up

- 4.5.1 **Do not work alone; someone must be nearby in case of an emergency** (within calling distance).
- 4.5.2 When using cut-off saws in residential areas, please observe the local noise regulations.
- 4.5.3 **Do not use the cut-off saw near combustible materials or explosive gases. There is a risk of sparking.**

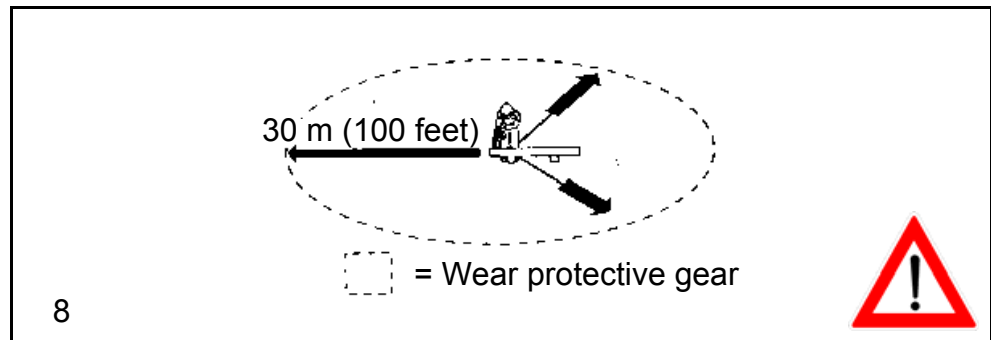

- 4.5.4 Ensure that persons (for example those assisting you) within a range of 30 m (100 feet) also wear protective gear (see "Personal Protective Gear") (8). Children or other persons must keep a distance of at least 30 m (100 feet) from the work area of the cut-off saw. Be aware of any animals in the vicinity (9).

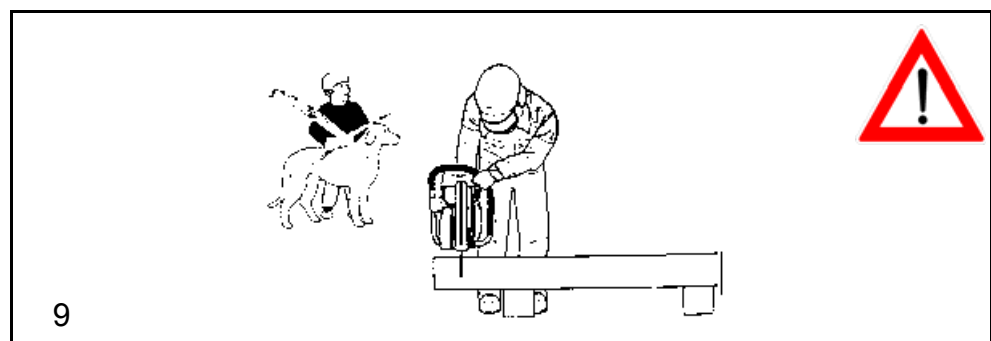

Safety information

- 4.5.5 Before you start to work with the cut-off saw, check to see that it is in proper working order and in a safe operating condition!

In particular, check the following: Inspect the condition of the cutting blade (replace immediately if the disc is cracked, bent or otherwise damaged). Check that the disc is properly mounted, the protective hood is locked in place, the belt guard is firmly attached, the V-belt is properly tightened, the throttle lever moves unhindered and functions correctly, the handles are clean and dry and the multifunction switch works.

- 4.5.6 Do not start the cut-off saw until you have completely assembled and tested it in operation. The cut-off saw must only be operated when it is completely assembled!

4.6 Cutting blades

- 4.6.1 The protective hood must always be attached. Change the cutting blade only when the engine has been turned off!

If you are using diamond-edged cutting blades, make sure you observe the attached rotational direction mark.

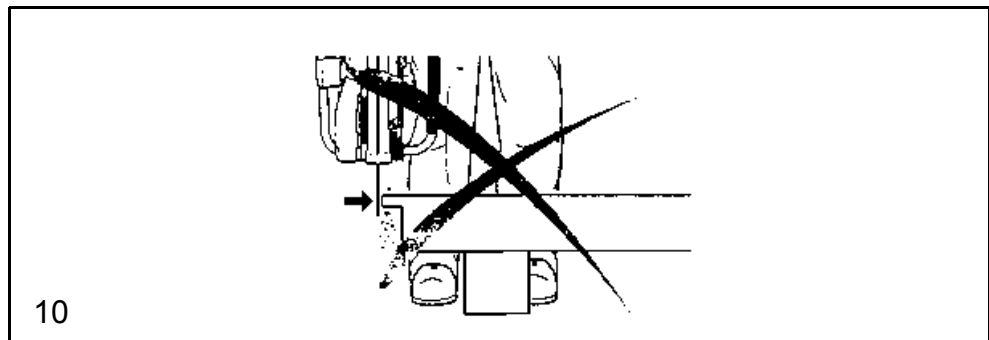

- 4.6.2 Cutting blades are only designed to cut materials on their edges. Never use the side surfaces for grinding purposes as this can break the disc! (10).

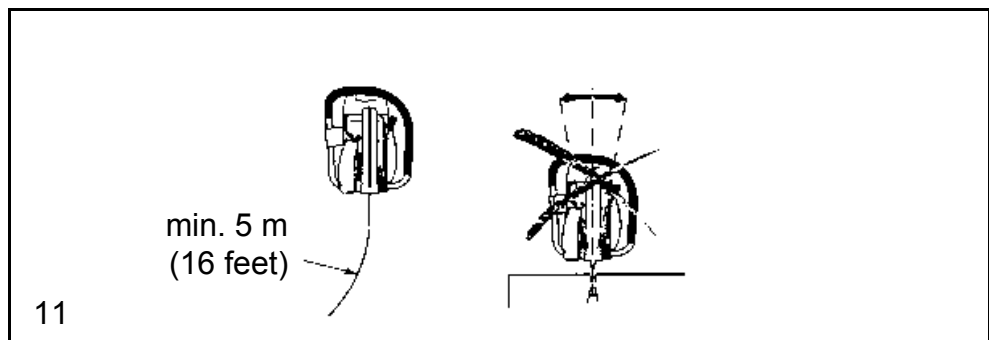

NOTICE:

It is prohibited to change the direction (a radius of 5 m (16 feet) or less), apply lateral pressure or tilt the cut-off saw while you are cutting (11)!

- 4.6.3 Cutting blades must only be used to cut materials they were designed for. Depending on the material you wish to cut (metal or concrete), you must select the proper disc type.
- 4.6.4 The arbor diameter of the cutting blade must precisely fit the shaft. If the arbor diameter is larger, you must use an intermediate ring as an adapter.
- 4.6.5 The cutting blade must be approved for freehand cutting with a 400 mm (16") cutting blade diameter up to 3,850 rpm or 80 m/s (260 ft./sec), a 350 mm (14") cutting blade diameter up to 4,370 rpm or 80 m/s (260 ft./sec) or a 300 mm (12") cutting blade diameter up to 5,100 rpm or 80 m/s (260 ft./sec). Use only cutting blades that comply with EN 12413 or EN 13236.

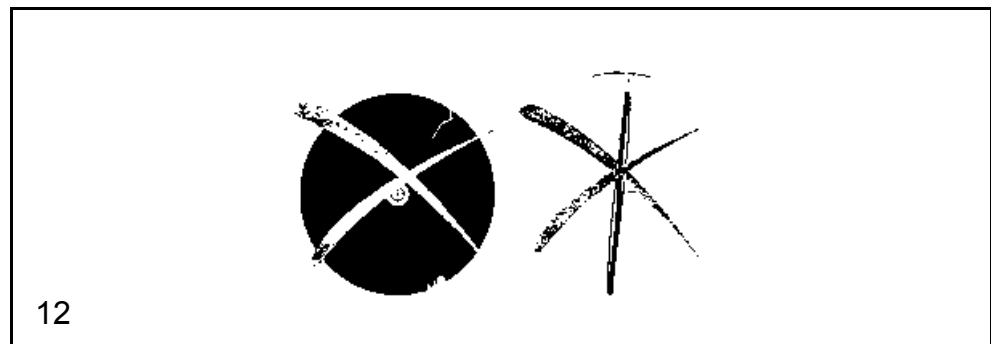

- 4.6.6 The cutting blade must be completely undamaged (12). Test it by performing a sound test with a piece of wood.
Always tighten the cutting blade to 30 Nm, otherwise you may distort the cutting blade.
- 4.6.7 Before starting, the operator must stand at safe distance away from the cut-off saw.

Safety information

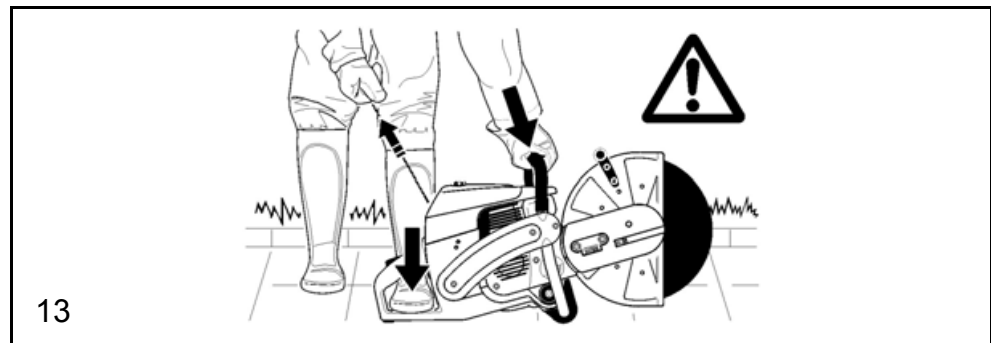

- 4.6.8 Start the cut-off saw only as described in the operator's manual (13). Always set your left foot into the handle and firmly hold the bow handle grip handle by using your thumb. Starting the machine in any other way is not permitted.
- 4.6.9 When you start up the machine, support it well and hold it firmly. The cutting blade must be freestanding.
- 4.6.10 A new cutting blade must be tested before you cut with it by running it at least 60 seconds at the specified maximum speed. Ensure that no one is in the extended swing area of the cutting blade.
- 4.6.11 **When operating the cut-off saw, hold it firmly with both hands.** The right hand on the rear handle, and the left hand on the bow handle grip. Hold the grips firmly using your thumbs.
- 4.6.12 **When you release the throttle lever, the cutting blade will continue to run briefly** (afterrun).
- 4.6.13 Always ensure that you are standing in a secure position.
- 4.6.14 Hold the cut-off saw in such a way that you cannot inhale the exhaust fumes. Do not work in closed rooms or in deep trenches (danger of poisoning through exhaust fumes).
- 4.6.15 If you notice any changes in the way the machine operates, turn off the engine immediately.

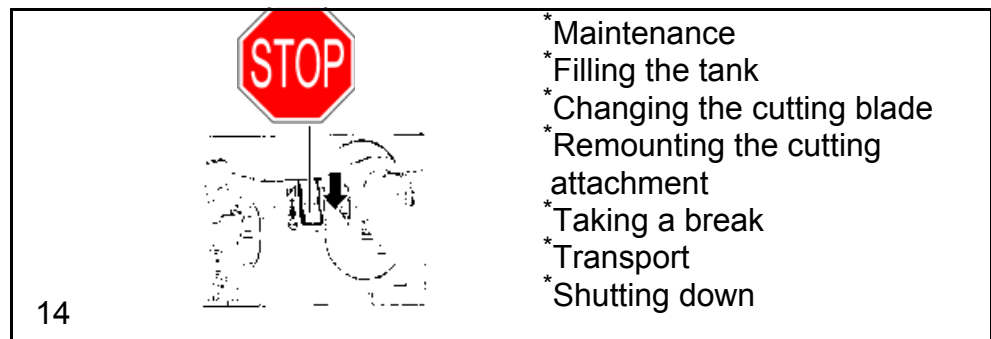

- 4.6.16 **You must turn off the engine before you check the V-belt tension, retighten the belt, change the cutting blade, remount the cutting attachment (outer or center position) and eliminate malfunctions** (14).

Safety information

- 4.6.17 If you hear or feel a change in the way the machine is cutting, turn off the engine immediately and check the cutting blade.
- 4.6.18 During breaks and after you finish work, turn off (14) the cut-off saw and set it down so that the cutting blade is freestanding and cannot endanger anyone.
- 4.6.19 Do not lay the hot cutting blade on dry grass or onto combustible objects. The muffler radiates an enormous amount of heat (danger of fire).
- 4.6.20 **NOTICE:** After a wet cutting procedure, first shut off the stream of water and then let the cutting blade run another 30 seconds so that it can spin off the remaining water. This prevents corrosion.

4.7 Kickback and pulling motion

- 4.7.1 When working with the cut-off saw, it can kick back or suddenly pull you.

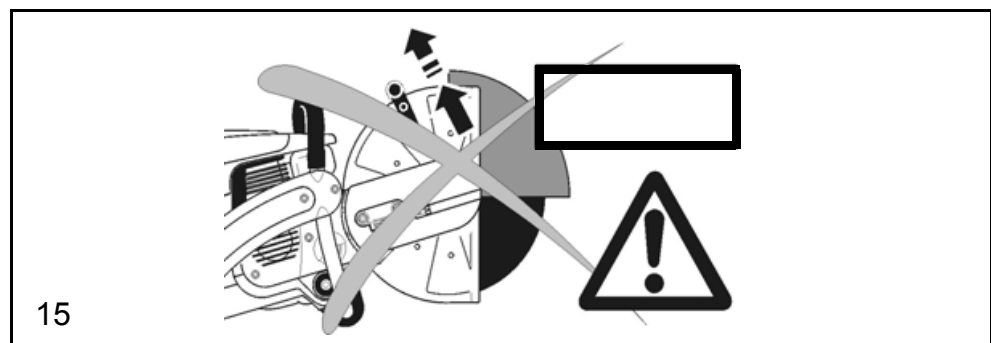

- 4.7.2 Kickback can occur if the upper area of the cutting blade is used for cutting (15).
- 4.7.3 The cut-off saw will skid or accelerate with great force toward the operator (**danger of injury!**).
To prevent kickback, observe the following:
- 4.7.4 Never use the area illustrated in Fig. 15 for cutting!
Exercise extra caution when inserting the tool into previously made cuts!
- 4.7.5 A pulling motion occurs when the cut is constricted (due to a crack or a workpiece under tension).
- 4.7.6 The cut-off saw will skid or accelerate forward with great force (**danger of injury!**).
To prevent this pulling motion, observe the following:
- 4.7.7 Always insert the tool into previously made cuts and carry out the cutting process at maximum speed.

Safety information

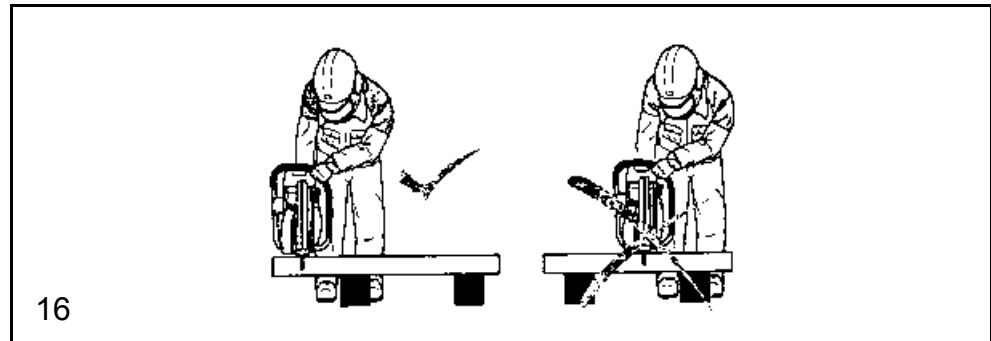

- 4.7.8 Always support the workpiece such that the cut is under tensile stress (16) so that the cutting blade is not pinched as cutting progresses.
- 4.7.9 When starting the cutting process, always move the cutting blade carefully toward the workpiece. Avoid uncontrolled movements.
- 4.7.10 Never cut through several workpieces at once! When cutting, make sure that the tool does not contact other workpieces.

4.8 Work habits and methods

- 4.8.1 Before starting operation, check the work area for any hazards (electrical cables, flammable materials). Clearly indicate the work area (e.g. set up warning signs or barriers).
- 4.8.2 During operation, hold the cut-off saw tightly using the front and rear handles. Never allow the cut-off saw to run unattended!
- 4.8.3 When possible, operate the cut-off saw with nominal spindle speed (see "Technical data").
- 4.8.4 Only work in well-lit areas with good visibility. Be particularly careful regarding slippery or wet surfaces, ice and snow (slipping hazard).
- 4.8.5 Never work on an instable surface. Exercise caution with obstacles in the work area that present a tripping hazard! Always ensure that you are standing in a secure position.

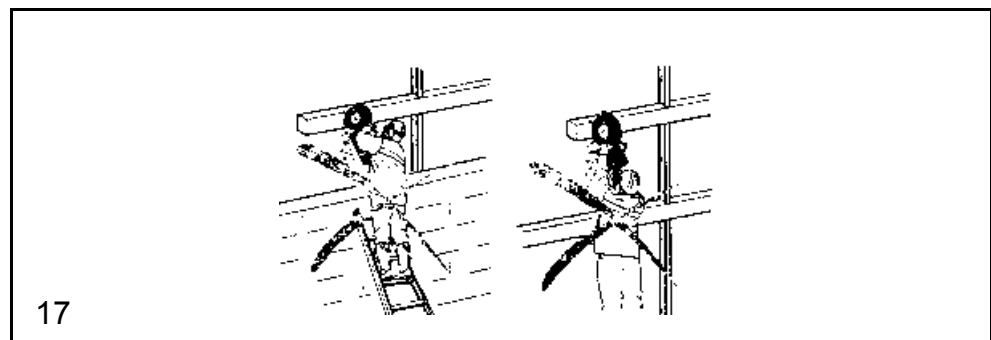

- 4.8.6 Never cut above shoulder height (17).

Safety information

- 4.8.7 Never cut while standing on a ladder (17).
- 4.8.8 Never work with the cut-off saw on a scaffolding.
- 4.8.9 Do not bend too far forward when working. Always use your knees to lift or put down the cut-off saw. Do not bend down from the waist.

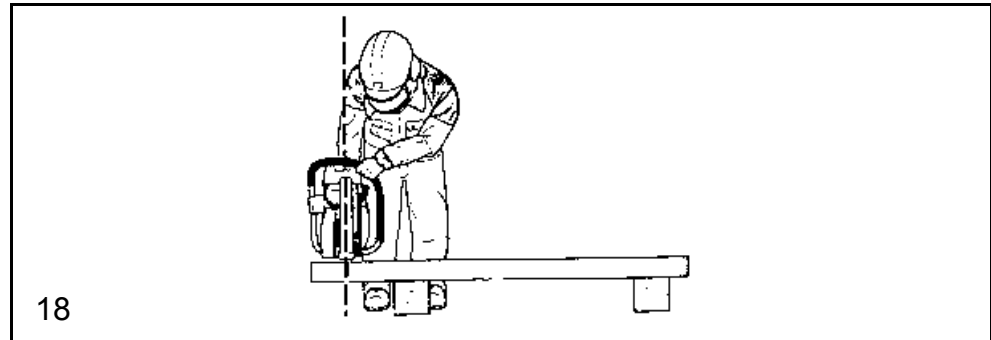

- 4.8.10 When moving the cut-off saw, ensure that none of your body parts is in the extended swing area of the cutting blade (18).
- 4.8.11 Cutting blades must only be used to cut materials they were designed for.
- 4.8.12 Do not use the cut-off saw to lift or shovel workpiece scraps or other objects out of the way.
Caution, risk of injury! Before beginning the cutting process, remove objects such as stones, nails, etc. from the cut area. Such objects can be flung away and cause injuries.
- 4.8.13 When cutting workpieces to length, use a secure support and, if necessary, secure them so they cannot slide away. Do not use your foot to hold the workpiece down. Do not allow another person to hold the workpiece down.
- 4.8.14 Round workpieces must be secured so they do not rotate during the cutting process.
- 4.8.15 Guide the cut-off saw by hand only if necessary with the cutting attachment in the outer position. A cut-off saw with the cutting attachment in the center position has a better center of gravity, which helps prevent early fatigue.

4.9 Instructions for using synthetic resin cutting blades

NOTICE!

- 4.9.1 Synthetic resin cutting blades can absorb moisture. When the cutting blade rotates quickly, the absorption of moisture causes eccentric weight distribution. The eccentric weight can break the blade.
- 4.9.2 Do not cool synthetic resin cutting blades with water or another liquid.

Safety information

- 4.9.3 Do not expose synthetic resin cutting blades to high humidity or rain!
- 4.9.4 Only use synthetic resin cutting blades up to their expiration date! This date (quarter/year) is engraved on the cutting blade supporting ring.

EXAMPLE: 04 / 2007

With proper use and storage, this cutting blade can be used up to and including the 4th quarter in 2007.

4.10 Cutting metals

NOTICE!

Wear proper breathing protection!

Materials that could discharge toxins may only be cut after notifying the responsible authorities and under their supervision or that of persons charged with this duty.

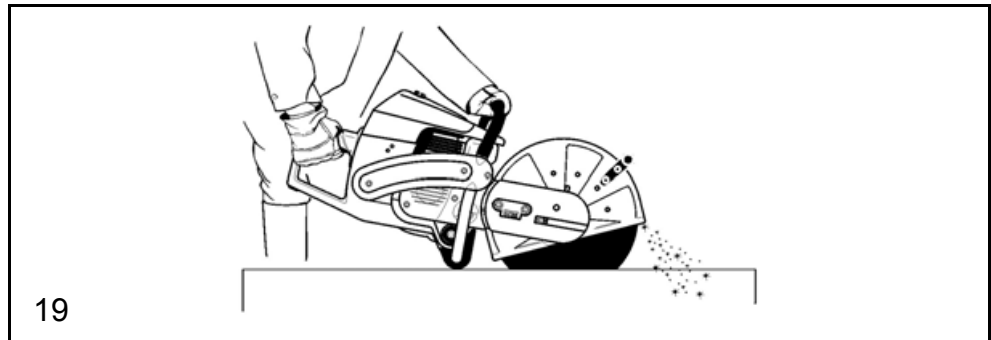

CAUTION!

The quick rotation of the cutting blade heats and melts metals at the contact point. As far from the cut as possible (behind it), swivel the protective hood down (19) to divert flying sparks away from the operator (greater danger of fire!).

- 4.10.1 Determine and mark the cutting direction and bring the cutting blade into contact with the material, rotating at average speed. After cutting a guide groove you can work at full throttle and higher pressure.
- 4.10.2 Cut only in the vertical or horizontal direction, not at an angle, which can break the blade.
- 4.10.3 The best way to achieve a square, smooth cut is to pull or reciprocate the cut-off saw. Do not "push" the cutting blade into the material.

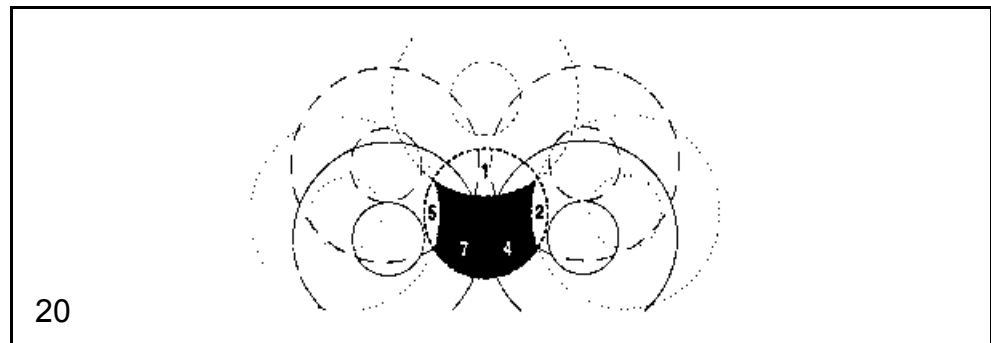

- 4.10.4 Cut large rods in stages (20).
- 4.10.5 Thin pipes can be cut with a simple downward cut.
- 4.10.6 Treat large diameter pipes as large rods. To avoid canting and for better control of the cutting process, do not allow the cutting blade to cut too deep into the material. Always make shallow cuts around the perimeter.
- 4.10.7 Worn cutting blades with a small diameter have a lower peripheral speed at the same engine speed and do not cut as well.

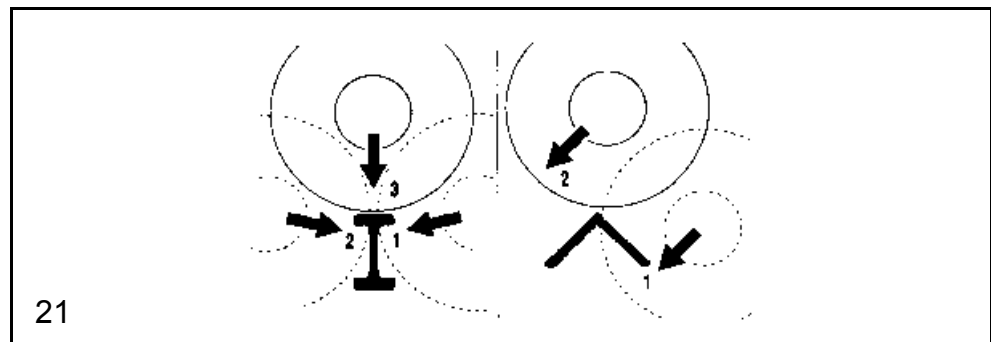

- 4.10.8 Cut double T-girders or angle steel in stages. See illustration 21.
- 4.10.9 Cut steel strips or sheets like pipes: pull evenly and use a long cutting surface.

Safety information

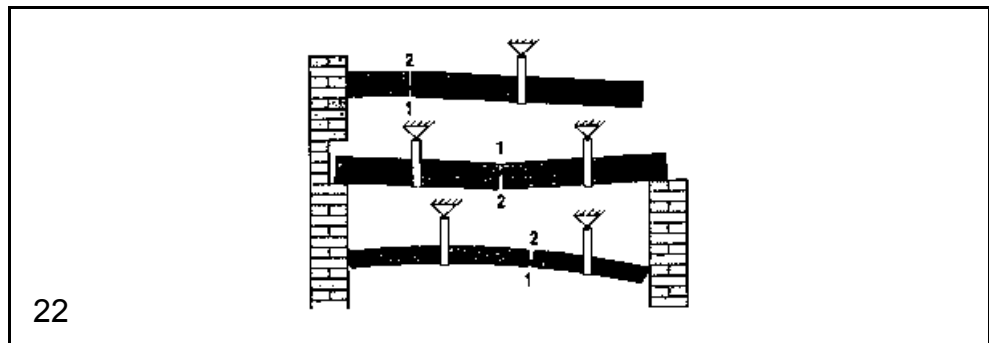

- 4.10.10 Always notch material that is under tension (material that is supported or embedded in a wall) on the pressure face and then cut from the opposite side so that the cutting blade does not get pinched (22). **Secure the material that is to be cut so that it does not fall!**

NOTICE!

In case of suspected tension, be prepared for the material to kick back and make sure you can move away, should it occur.

Use extra caution in scrapyards, accident scenes or unsorted stacks of material. Material that is under tension, slipping or cracking is unpredictable. Secure the material that is to be cut so that it does not fall (22)! Work very carefully and only with machines that are in perfect condition.

Observe the accident prevention regulations set forth by the professional liability insurance association.

4.11 Cutting stone, concrete, asbestos or asphalt

NOTICE!

Wear proper breathing protection!

Asbestos or materials that could discharge toxins may only be cut after notifying the responsible authorities and under their supervision or that of persons charged with this duty. When cutting concrete piles that are under tension and contain metal, comply with the instructions and norms from the respective authorities or part manufacturers. The process for cutting through reinforcing bars must be carried out in the proper order, taking the respective safety regulations into account.

NOTE!

When cut, mortar, stone or concrete generate a great deal of fine dust. To extend the service life of the cutting blade (cooling medium), to enable a better visual inspection and to prevent excessive dust formation, wet cutting is preferred over dry cutting. Both sides of the cutting blade must be sprayed evenly with water. You can find the right equipment for every wet cutting application in the WACKER product range.

- 4.11.1 Before beginning the cutting process, remove objects such as stones, nails, etc. from the cut area.

Notice: Make sure that you know where the electrical cable is!

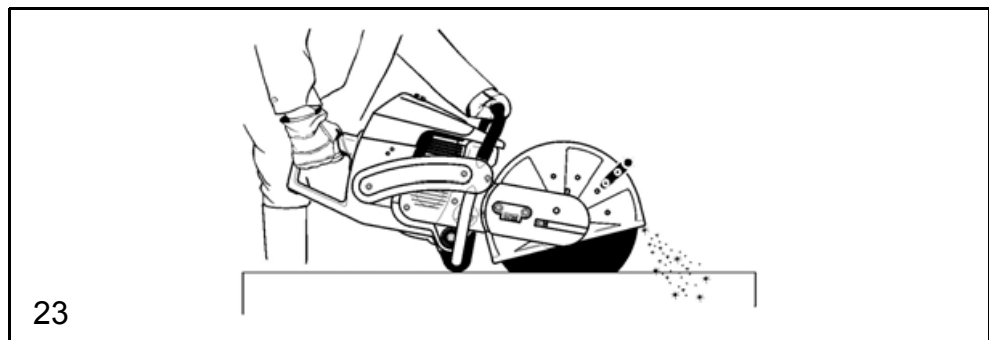

The quick rotation of the cutting blade at the contact point tears the material and throws it out of the cutting groove. As far from the cut as possible (behind it), swivel the protective hood down (23) to divert the workpiece particles that have been cut away from the operator.

- 4.11.2 Mark the cutting line and grind a groove ca. 5 mm (0.2") deep along the entire length of the workpiece at half throttle, which will guide the cut-off saw exactly during the subsequent cutting process.



NOTE:

Using a guide cart (24) is recommended for long, straight cuts. It makes guiding the cut-off saw in a straight pass easier and doesn't require as much effort.

Safety information

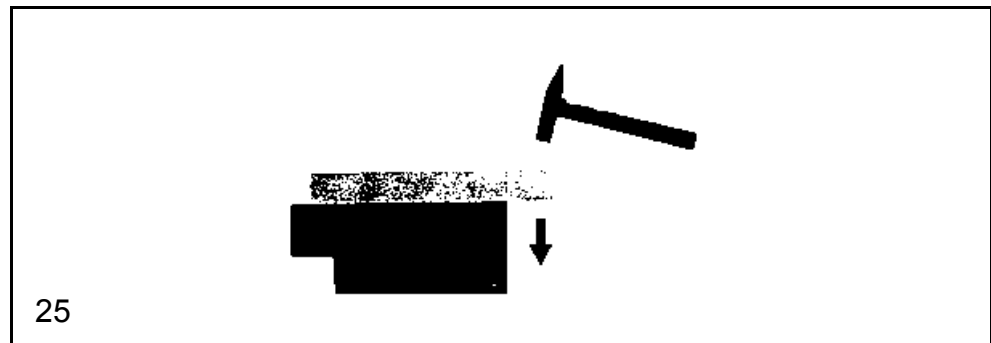

- 4.11.3 When truing stone slabs you only need to grind one groove (to prevent unnecessary dust formation), and then place the slab on a flat base and knock off the overhanging piece (25).

NOTICE!

For cutting to length, prevent the cut section from pinching the cutting blade and to avoid injuries due to falling parts, determine the direction of the cut and the order of the steps to be carried out.

4.12 Transport and storage

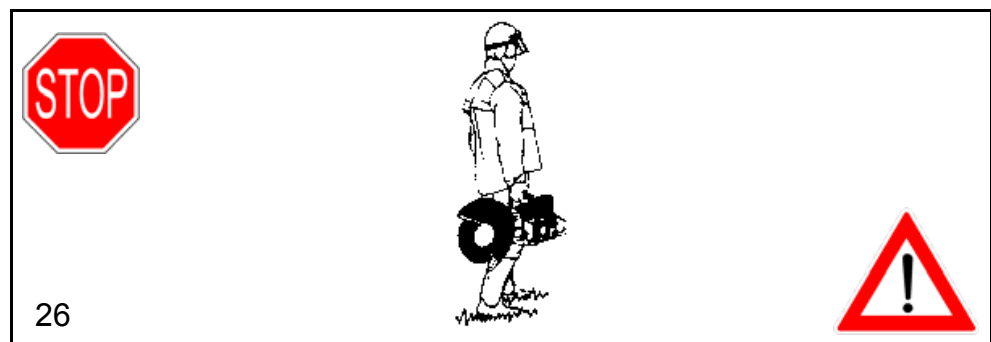

- 4.12.1 **Turn off the cut-off saw when transporting it or moving it to another location while working (26).**
- 4.12.2 Never carry or transport the cut-off saw while the engine or the cutting blade is running!
- 4.12.3 Use only the bow handle grip to carry the cut-off saw. The cutting blade points to the rear (26). Do not touch the muffler (can cause burns).
- 4.12.4 For transport over a substantial distance, use a wheelbarrow or a cart.
- 4.12.5 When transporting by truck ensure that the cut-off saw is in a stable position so that that no fuel runs out. Always detach the cutting blade when transporting by truck.

- 4.12.6 Store the cut-off saw securely in a dry area. Do not store it outdoors. Always detach the cutting blade. Do not allow children near the cut-off saw.
- 4.12.7 **Before a long storage period and before shipping the cut-off saw make sure to follow the "Periodic maintenance and service instructions". Always empty the fuel tank and run the carburetor empty.**
- 4.12.8 Proceed especially carefully when storing the cutting blades:
- 4.12.9 Clean them and dry them well.
NOTICE:
Do not clean synthetic resin cutting blades with water or other liquids!
- 4.12.10 Always lay them flat to store them.
- 4.12.11 Avoid the risk of splintering or breakage by preventing contact with moisture, frost, direct sunlight, high temperatures or temperature fluctuation!
- 4.12.12 Check the expiration date before using the synthetic resin cutting blades again after storage (engraved on the supporting ring - quarter/year). If the expiration date has passed, the cutting blade may not be used.
- 4.12.13 Always check new cutting blades or those from storage for damage and test them by running them at least 60 seconds at the specified maximum speed. Ensure that no one is in the extended swing of the cutting blade.

4.13 Maintenance



- 4.13.1 **Before you carry out any maintenance work, always turn off the cut-off saw (27) and pull off the spark plug connector!**
- 4.13.2 Check that the cut-off saw is in a safe operating condition before you start work. Make sure that the cutting blade has been attached according to instructions. Also make sure that the cutting blade is undamaged and suited for the application at hand.
- 4.13.3 While operating the machine, try to produce as little noise and exhaust fumes as possible. Check the carburetor setting.
- 4.13.4 Clean the cut-off saw regularly.

Safety information

- 4.13.5 Check the tank cap regularly to make sure it is on tightly.
- 4.13.6 Observe the accident prevention regulations set forth by the professional liability insurance association. Never attempt to modify the cut-off saw! Doing so will endanger your safety!
- 4.13.7 Service and maintenance work must only be carried out to the extent described in these operator's manual. All other procedures must be performed by WACKER Service.
- 4.13.8 Use only WACKER spare parts and accessories.

Use of spare parts, accessories and cutting blades not produced by WACKER increases your chances of having an accident. **If accidents or damage that occurs with accessories not produced by WACKER exempts the manufacturer from all liability.**

4.14 First Aid



A first aid kit in accordance with DIN 13164 should always be available in the working area in case an accident occurs. Immediately replace any materials that are removed.

When requesting assistance, provide the following information:

- * where it happened
- * what happened
- * how many are injured
- * what type of injuries
- * who is requesting assistance!

NOTE!

If persons with circulatory problems are exposed too often to vibrations, the blood vessels or nervous system can be damaged.

The following symptoms can occur due to vibrations experienced in the fingers, hands or wrists: Body parts can "go to sleep," tingling, pain, prickling, changes in skin color or in the skin itself.

If these symptoms occur, consult a doctor.

4.15 Disposal and environmental protection

Remember our environment!

Dispose of worn out or defective cutting blades according to local waste disposal regulations. To prevent misuse, destroy the cutting blades that can no longer be used before disposing of them.

When the machine has reached the end of its service life, recycle it or dispose of it in a way that does not harm the environment. If necessary, ask your local administration for more information.

Technical data

5. Technical data

		BTS 930L3	BTS 935L3
Item no.		0008987	0008988
Engine displacement	cm ³ (cu in)	64 (3.9)	
Bore	mm (in)	47 (1.85)	
Stroke	mm (in)	37 (1.46)	
Max. performance	kW (hp)	3.3 (4.5)	
Max. torque	Nm (ft.lbs.)	4.0 (3.0)	
Idle speed	rpm	2,500	
Clutch engaging speed	rpm	3,800	
Limiting speed	rpm	9,350	
Nominal spindle speed	rpm	4,300	
Sound pressure level $L_{pA\ eq}$ according to EN 1454 ^{1) 4)}	dB(A)	97	
Sound power level	L_{WA}	109 dB(A)	
Vibrational acceleration $a_{h,w}$ according to EN 1454 - Bow handle grip (idle/nominal spindle speed) - Handle (idle/nominal spindle speed)	m/s ²	6 / 5 8 / 6	
When using the guide cart FBTS: Vibrational acceleration $a_{h,w}$ according to EN 1454 (for the guide cart)	m/s ²	2.5	
Ignition system (with maximum rpm limitation)	Type	Electronic	
Spark plug	Type	NGK BPMR 7A / BOSCH WSR 6F / CHAMPION RCJ 6Y	
Spark plug air gap	mm (in)	0.5 (.020)	
Fuel consumption at max. capacity according to ISO 8893	l/h (US qt/h)	2.1 (2.2)	
Special consumption at max. capacity according to ISO 8893	g/kWh (oz./hph)	500 (13)	
Fuel tank capacity	l (US qt)	1.1 (1.2)	
Gasoline/2-cycle oil mixing ratio ⁵⁾		50:1	
Cutting blade for max. 80 m/s (260 ft/sec.) ²⁾	mm (in)	300 / 20.0 / 5 ³⁾ (12/0.787/0.2)	350 / 25.4 / 5 ³⁾ (14/1/0.2)
Spindle diameter	mm (in)	20.0 (0.787")	25.4 (1")
Weight of cut-off saw (empty tank, without cutting blade)	kg (lb)	10.0 (22)	10.2 (22.5)

¹⁾ Data takes the operating states idle and top speed equally into consideration.

²⁾ Peripheral speed at the highest engine speed.

³⁾ Outer diameter/centre bore/thickness.

⁴⁾ At the working area (operator's ear).

⁵⁾ Only use 2-cycle engine oil of the specification JASO FC. or ISO L-EGD!

Technical data

		BTS 1030L3	BTS 1035L3
Item no.		0008989	0008990
Engine displacement	cm ³ (cu in)	73 (4.5)	
Bore	mm (in)	50 (1.97)	
Stroke	mm (in)	37 (1.46)	
Max. performance	kW (hp)	4.2 (5.7)	
Max. torque	Nm (ft.lbs.)	5.0 (3.7)	
Idle speed	rpm	2,500	
Clutch engaging speed	rpm	3,800	
Limiting speed	rpm	9,350	
Nominal spindle speed	rpm	4,300	
Sound pressure level L _{pA eq} according to EN 1454 ^{1) 4)}	dB(A)	99	
Sound power level	L _{WA}	110 dB(A)	
Vibrational acceleration a _{h,w} according to EN 1454 - Bow handle grip (idle/nominal spindle speed) - Handle (idle/nominal spindle speed)	m/s ²	7 / 5 8 / 7	
When using the guide cart FBTS: Vibrational acceleration a _{h,w} according to EN 1454 (for the guide cart)	m/s ²	2.5	
Ignition system (with maximum rpm limitation)	Type	Electronic	
Spark plug	Type	NGK BPMR 7A / BOSCH WSR 6F / CHAMPION RCJ 6Y	
Spark plug air gap	mm (in)	0.5 (.020)	
Fuel consumption at max. capacity according to ISO 8893	l/h (US qt/h)	2.7 (2.9)	
Special consumption at max. capacity according to ISO 8893	g/kWh (oz./hph)	500 (13)	
Fuel tank capacity	l (US qt)	1.1 (1.2)	
Gasoline/2-cycle oil mixing ratio ⁵⁾		50:1	
Cutting blade for max. 80 m/s ²⁾	mm (in)	300/20.0/5 ³⁾ (12/0.787/0.2)	350/25.4/5 ³⁾ (14/1/0.2)
Spindle diameter	mm (in)	20.0 (0.787")	25.4 (1")
Weight of cut-off saw (empty tank, without cutting blade)	kg (lb)	10.0 (22)	10.2 (22.5)

¹⁾ Data takes the operating states idle and top speed equally into consideration.

²⁾ Peripheral speed at the highest engine speed.

³⁾ Outer diameter/centre bore/thickness.

⁴⁾ At the working area (operator's ear).

⁵⁾ Only use 2-cycle engine oil of the specification JASO FC. or ISO L-EGD!

Technical data

		BTS 1140L3
Item no.		0610063
Engine displacement	cm ³ (cu in)	81 (4.9)
Bore	mm (in)	52 (2.05)
Stroke	mm (in)	38 (1.50)
Max. performance	kW (hp)	4.5 (6.1)
Max. torque	Nm (ft.lbs.)	5.2 (3.8)
Idle speed	rpm	2,500
Clutch engaging speed	rpm	3,800
Limiting speed	rpm	9,350
Nominal spindle speed	rpm	3,750
Sound pressure level $L_{pA_{eq}}$ according to EN 1454 ^{1) 4)}	dB(A)	98.3
Sound power level	L_{WA}	108 dB(A)
Vibrational acceleration $a_{h,w}$ according to EN 1454 - Bow handle grip (idle/nominal spindle speed) - Handle (idle/nominal spindle speed)	m/s ²	5.6 / 6.3 8.8 / 6.0
When using the guide cart FBTS: Vibrational acceleration $a_{h,w}$ according to EN 1454 (for the guide cart)	m/s ²	2.5
Ignition system (with maximum rpm limitation)	Type	Electronic
Spark plug	Type	NGKBPMR 7A / BOSCH WSR 6F / CHAMPION RCJ 6Y
Spark plug air gap	mm (in)	0.5 (.020)
Fuel consumption at max. capacity according to ISO 8893	l/h (US qt/h)	2.9 (3.2)
Special consumption at max. capacity according to ISO 8893	g/kWh (oz./hph)	500 (13)
Fuel tank capacity	l (US qt)	1.1 (1.2)
Gasoline/2-cycle oil mixing ratio ⁵⁾		50:1
Cutting blade for max. 80 m/s ²⁾	mm (in)	400/25.4/5 ³⁾ (16/1/0.2)
Spindle diameter	mm (in)	25.4 (1.0")
Weight of cut-off saw (empty tank, without cutting blade)	kg (lb)	10.6 (23.4)

¹⁾ Data takes the operating states idle and top speed equally into consideration.

²⁾ Peripheral speed at the highest engine speed.

³⁾ Outer diameter/centre bore/thickness.

⁴⁾ At the working area (operator's ear).

⁵⁾ Only use 2-cycle engine oil of the specification JASO FC. or ISO L-EGD!

6. Part identification

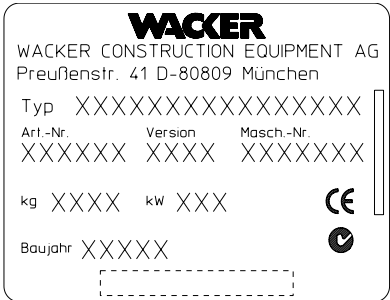

Nameplate
Please indicate when ordering replacement parts!

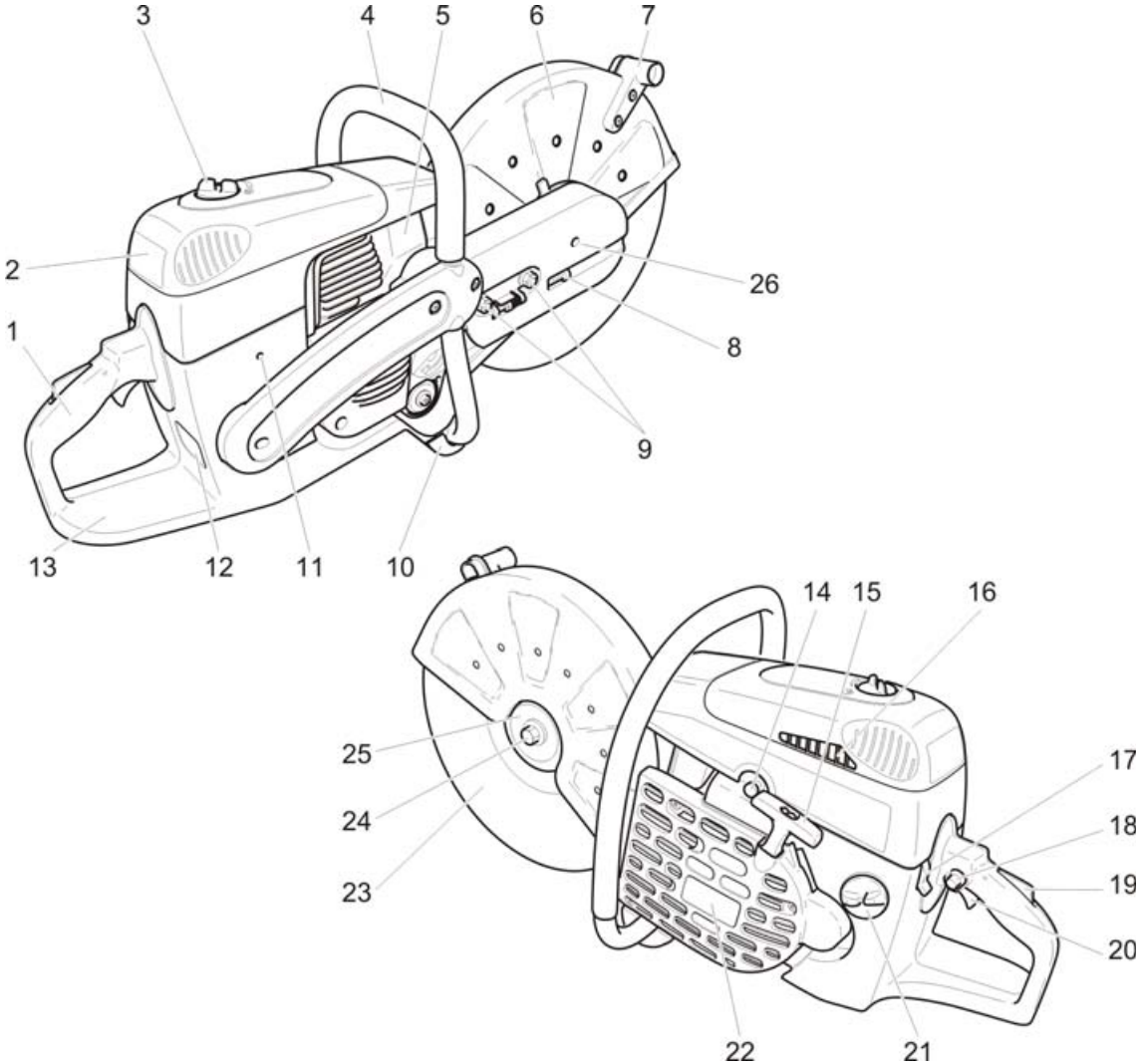

Part identification

- 1 Handle
- 2 Filter cover for air cleaner and spark plug cap
- 3 Cover lock
- 4 Bow handle grip
- 5 Muffler
- 6 Protective hood
- 7 Handle for protective hood
- 8 Adjusting screw for tightening the V-belt
- 9 Fastening nuts
- 10 Base
- 11 Opening for setting the carburetor
- 12 Nameplate
- 13 Tank with hand guard
- 14 Decompression valve
- 15 Starter handle
- 16 Air intake port
- 17 Multifunction switch "Start/Stop" (I/O) choke
- 18 Lock button for half throttle
- 19 Safety switch
- 20 Throttle lever
- 21 Fuel tank seal
- 22 Valve housing with starting device
- 23 Cutting blade
- 24 Fastening screw for cutting blade
- 25 Clamping disc
- 26 Opening for counterholder

7. Starting up



30

NOTICE:

Before working on the cut-off saw, always turn off the engine, pull off the spark plug connector and wear protective gloves!

NOTICE:

The cut-off saw must not be started until it has been completely assembled and tested!

Always use the assembly tools included in delivery for the following procedures:

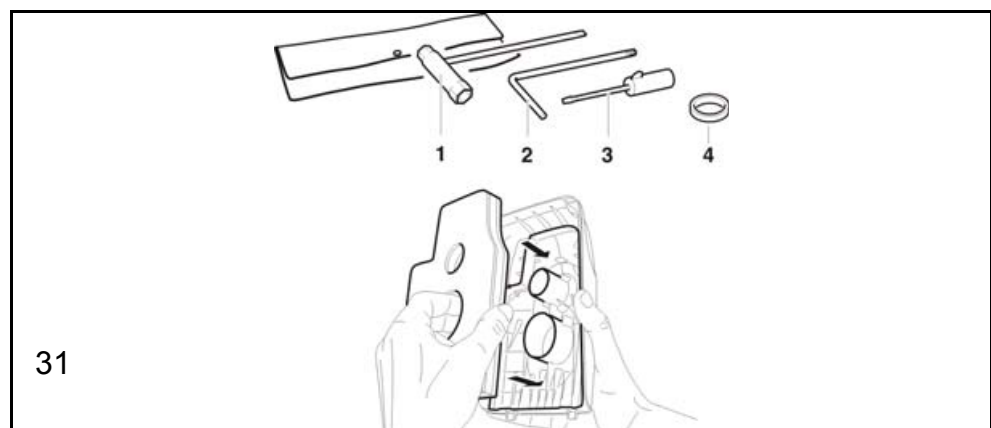

31

- 1 Combination wrench 13/19 mm
- 2 Offset screwdriver
- 3 Screwdriver for setting the carburetor
- 4 Adapter ring (not usually included in delivery)

NOTE: Only for the BTS 1140L3 model

No air cleaner mounted!

Before starting operation, insert the oiled foam air cleaner (prefilter) as shown in illustration 31! First remove the filter cover (see chapter Cleaning/Changing the air cleaner).

Knead the foam air cleaner in the packaging prior insertion to ensure distribution of the oil. Remove the packaging afterwards.

Starting up

7.1 Attaching the cutting blade

Set the cut-off saw onto a sturdy base and carry out the following assembly steps:

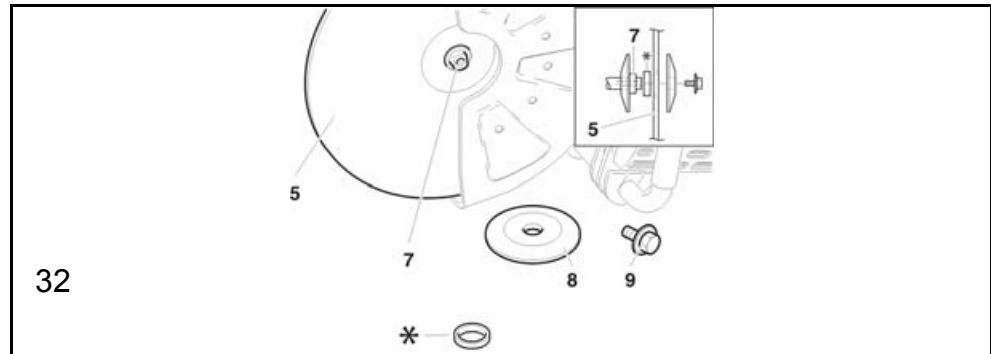

Check the cutting blade for damage. See SAFETY INFORMATION. Unscrew the screw (9) and remove the clamping disc (8). Set the cutting blade (5) onto the shaft (7).

NOTE: The arbor diameter of the cutting blade must precisely fit the shaft. If the arbor diameter is larger, you must use an adapter ring (*).



NOTICE:

If you are using diamond-edged cutting blades, make sure you observe the attached rotational direction mark!

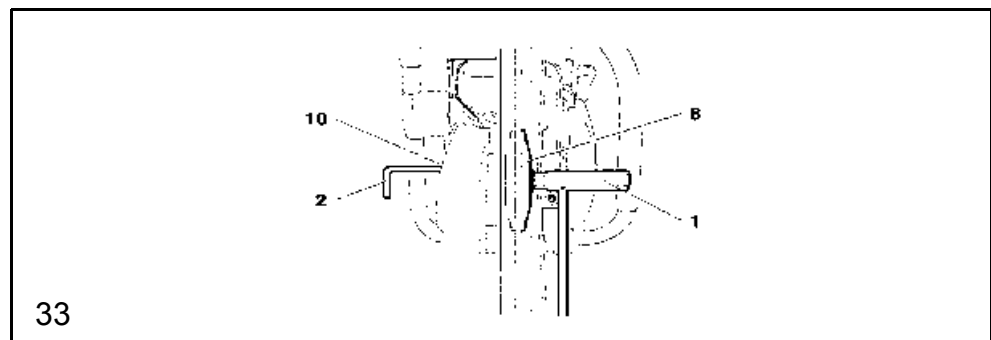

Set the clamping disc (8) onto the shaft, screw in together with the screw (32/9) and tighten by hand.

Turn the cutting blade slowly until you can see the locking bore of the V-belt pulley bolt through the gear arm hole (10).

Press the offset screwdriver (2) all the way in. The shaft is now blocked.

Firmly tighten the screw with the combination wrench (1).

NOTE: Firmly tighten the screw to 30 ± 2 Nm (22 ± 1.5 ft.lbs.), otherwise the cutting blade may slip while cutting.

7.2 Tightening the V-belt/Checking the tension



34

NOTICE:

To obtain the maximum cutting performance at the lowest fuel consumption, it is absolutely necessary to tighten the V-belt precisely. An incorrectly tightened V-belt leads to premature wearing of the V-belt and V-belt pulley or to damage on the clutch bearing. Retighten the V-belt after one hour of operation!

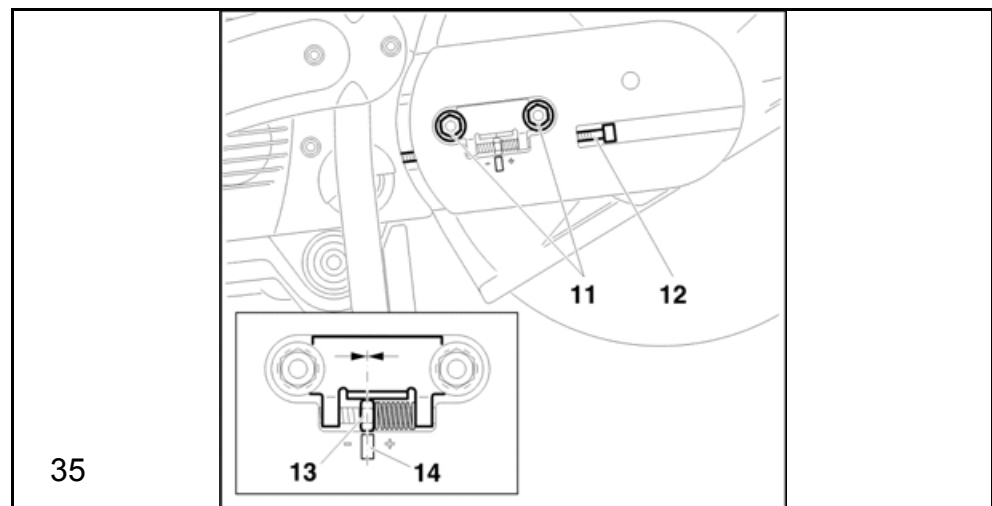

35

NOTE: To tighten the V-belt and to check the tension, you must loosen both mounting nuts (11).

To increase the tension, turn the tension screw (12) in the clockwise direction with the combination wrench included in delivery.

The V-belt is correctly adjusted if the marking (14) is centered between the nuts (13).



NOTICE: After tightening/testing the V-belt, make sure to tighten the mounting nuts (11) to 30 ± 2 Nm (22 ± 1.5 ft.lbs.).

Starting up

7.3 Operating fluids

NOTICE:

The unit uses mineral oil products (gasoline and oil)!

Take special precautions when handling gasoline.

Smoking and open fires are not permitted (danger of explosion).



Fuel 50:1

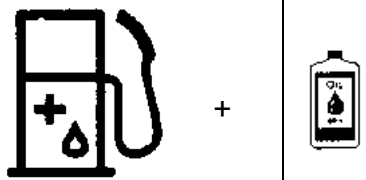

1,000 cm ³ (1 liter)	20 cm ³
5,000 cm ³ (5 liters)	100 cm ³
10,000 cm ³ (10 liters)	200 cm ³
1.0 Us-gal	2.5 floz.
2.5 Us-gal	6.4 floz.
5.0 Us-gal	12.8 floz.

Preparing the correct gasoline/oil mixing ratio:
50:1 Mix 50 parts of fuel with one part of oil.

36

Fuel mixture

The cut-off saw engine is a high-performance two-cycle engine. It is operated with a mixture of fuel and two-cycle engine oil.

The engine is designed for use with normal unleaded gasoline with a minimum octane rating of 91 ROZ (87 R+M). If this octane is not available, you may also use fuel of a higher octane rating. This will not damage your engine.

For optimum engine performance and for the sake of your own health and the environment, always use unleaded fuel! Do not use fuel that contains alcohol.

The two-cycle engine oil must meet the specification JASO FC or ISO L-EGD.

NOTE: To prepare the fuel-oil mixture, always premix the prescribed amount of oil volume with half of the fuel volume and then add the remaining amount of fuel. Before you fill the tank, always shake the finished mixture well.

NOTICE: Open the cap of the fuel tank carefully since there may be pressure present!

It is not a good idea to increase the oil percentage of the two-cycle mixture for beyond the specified mixing ratio for any reason. This will increase the amount of combustion residue which pollutes the environment and also clogs the exhaust port in the cylinder and the muffler. Furthermore, this also increases fuel consumption and reduces engine performance.

7.4 Storing fuel

Fuels cannot be stored indefinitely. Fuel and fuel mixtures age due to evaporation, particularly under the influence of high temperatures. Fuel and fuel mixtures that have been stored for too long can lead to problems with starting and engine damage. Purchase only enough fuel for a few months. Mixed fuels for use at high temperatures should be used within 6-8 weeks.

Store fuel only in approved containers in cool and secure areas!



AVOID CONTACT WITH SKIN AND EYES!

Mineral products and oils scour your skin. If used repeatedly and over time, they will dry out your skin. This could develop into one of various skin diseases. In addition, allergic reactions are also possible.

Oil in your eyes can cause irritations. If you get oil into your eye, rinse it out immediately with clean water.

If irritation continues, consult a physician immediately!

Starting up

7.5 Filling the tank

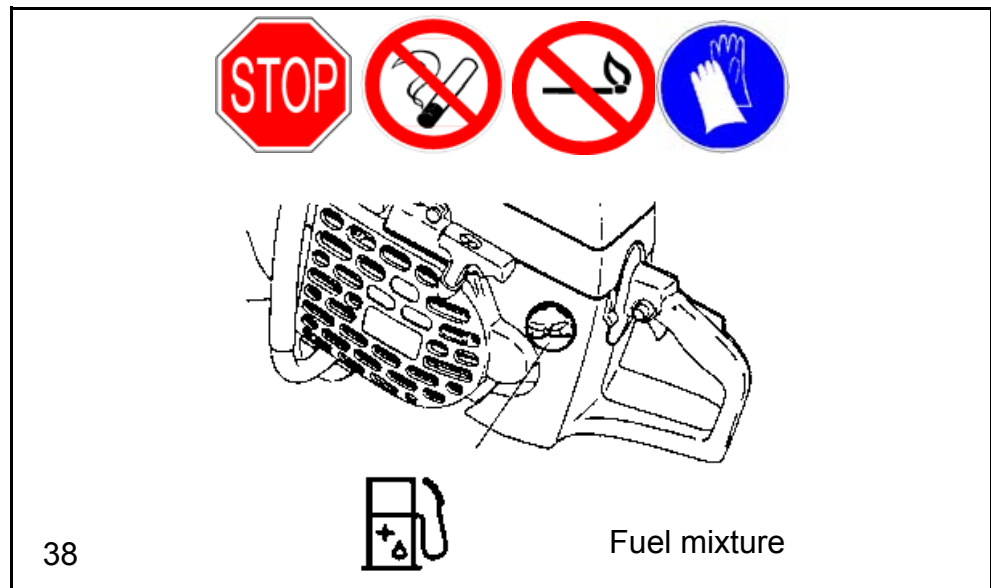

NOTICE: STRICTLY FOLLOW THE SAFETY INFORMATION!

Fuels must be handled carefully and prudently.

Only when the engine is turned off and has cooled down!

Clean the filling area so that no dirt can get into the tank.

Set the machine on its side on a flat base.

Screw off the tank cap and pour in the fuel mixture. Pour it in carefully to avoid spilling the fuel mixture.

Tightly screw the tank cap back on.

Clean the tank cap and surrounding area after you are finished! Never start or operate the unit at the location where you filled the tank! Should you spill fuel on your clothing, change your clothes immediately.

7.6 Starting the engine

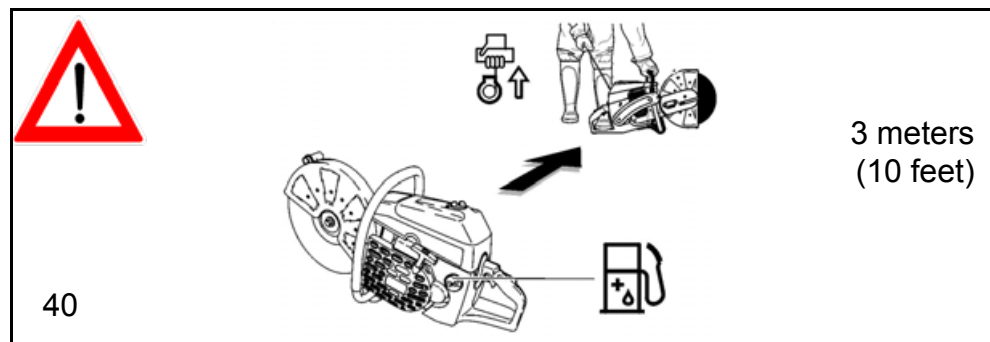
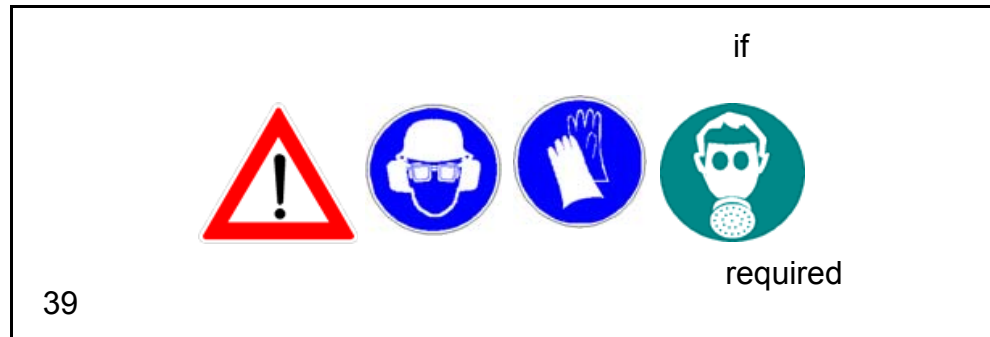

NOTICE:

Strictly follow the SAFETY INFORMATION.

The cut-off saw must not be started until it has been completely assembled and tested!

Take it at least 3 m (10 feet) away from the place where you filled the tank!

Stand squarely and set the cut-off saw onto the ground so that the cutting attachment is freestanding.

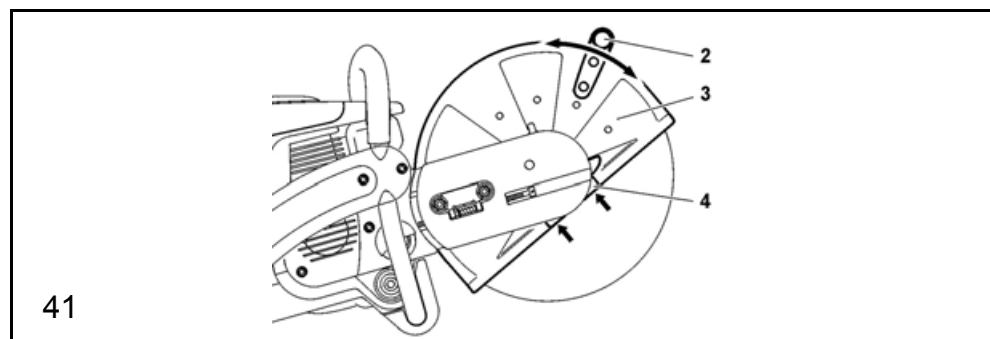

Move the protective hood (3) to the best position for the application at hand (see figure).

Grab the handle (2). The protective hood (3) can be swivelled within the stopmounts in both arrow directions.

Starting up

Notice:

Make absolutely sure that the straight edge of the stop plate (4) is parallel to the edge of the protective hood (see arrows).

If this is not the case, please take your machine to the shop.

7.6.1 Cold start

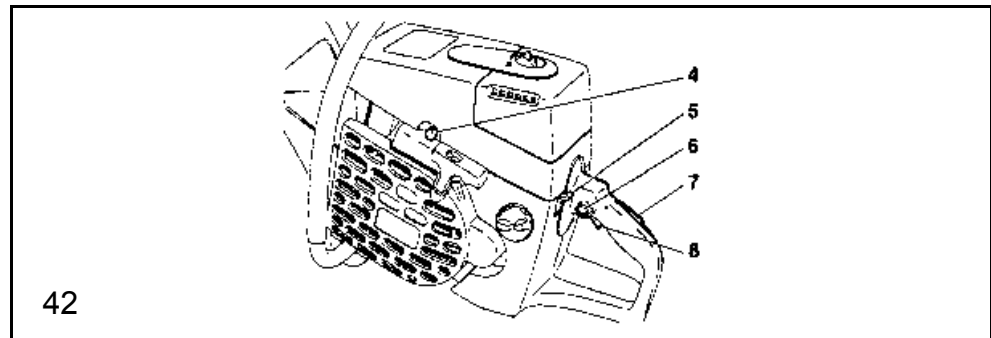

Press the multifunction switch (5) upward (choke position).

Put your hand around the handle (safety switch (7) is actuated by the palm of your hand).

Press the throttle lever (8) all the way through and hold it.

Press the lock button (6) and release the throttle lever (8) (throttle lever is locked in place by the lock button in the half-gas position). Press in the start valve (4).

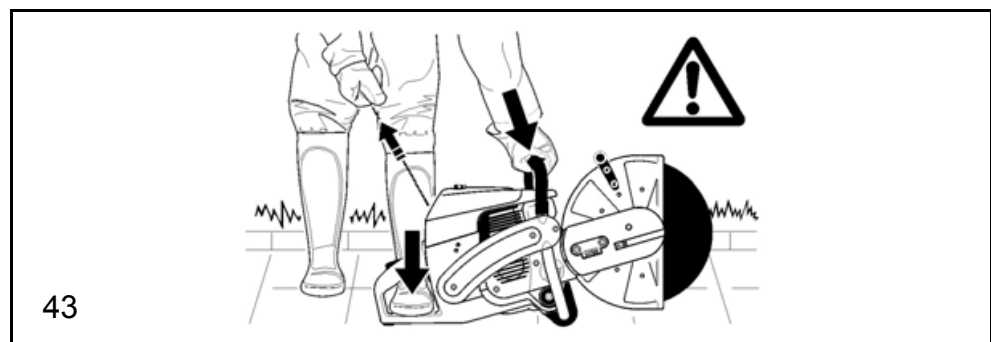

Put your hand around the bow handle grip and hold it firmly while you press the cut-off saw against the ground.

Place your left foot into the rear hand guard.

Pull out the starter rope slowly until you feel resistance (the piston is located before the top dead center).

Now continue pulling quickly with force until you hear the engine start.

Notice: Do not pull out the starter rope more than 50 cm (20") and let it rewind slowly by hand, not letting it go.

Press the multifunction switch (42/5) to the "I" position.

Pull the starter rope again until the engine runs.

Once the engine is running, tip the throttle lever (42/8) so that the lock button (42/6) snaps out and the engine idles.

7.6.2 Warm start

As described under cold start, however without pressing the multifunction switch (42/5) in the choke position.

7.7 Turning off the engine

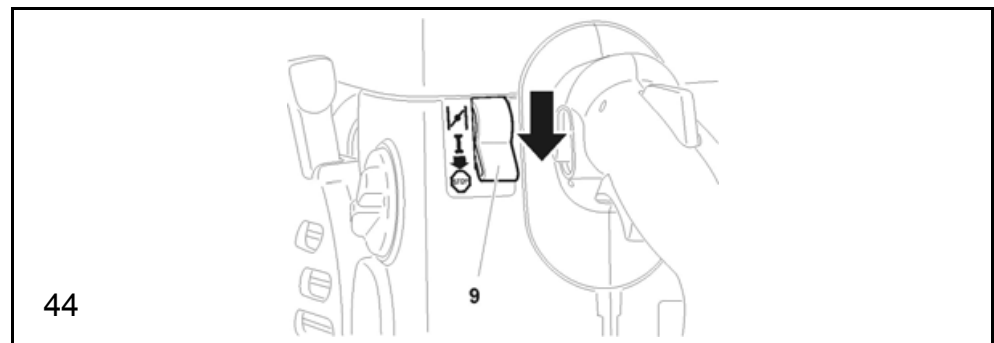

Press the multifunction switch (9) down to the "Stop" position.

7.8 Readjusting the idle speed



NOTE:

The cut-off saw is equipped with a speed limiting electronic ignition. In addition, the carburetor has a fixed nozzle that cannot be adjusted.

The idle speed has been factory set to approx. 2,500 rpm; however, the run-in procedure of a new machine requires a slight readjustment of the idle speed.

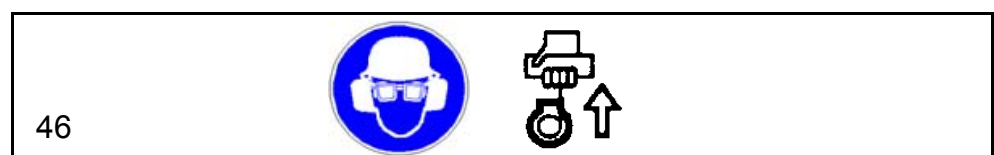

Starting up

The following steps are required to correctly set the idle speed:
Start the engine and let it warm up (approx. 3 - 5 minutes).

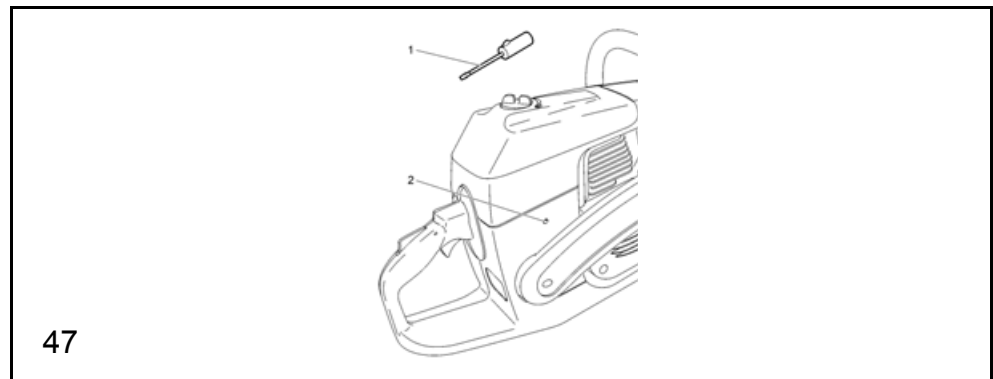

Set the speed for the idle position with the screwdriver that was included in delivery.

Readjust the idle speed

If the cutting blade rotates when the engine is running, screw the stop screws (2) for the choke outward until the cutting blade no longer rotates. If the engine stops when idling, turn the screw back in somewhat.



Turn off the engine

8. Maintenance work

NOTICE:

Only use spare parts from WACKER! Non-compliance will exempt the manufacturer from all liability.



NOTICE:

When working on the cut-off saw, always turn off the engine, remove the cutting blade, pull off the spark plug connector and wear protective gloves!

NOTICE:

The cut-off saw must not be started until it has been completely assembled and tested!

NOTE:

For your safety, regular checks and maintenance must be carried out at a WACKER service station because many parts not discussed in this operator's manual are important safety devices and, like all parts, are also subject to wear.



NOTICE:

If the cutting blade breaks during the cutting process, before starting the machine again it must be serviced in a WACKER shop!

Maintenance work

8.1 Replacing the V-belt

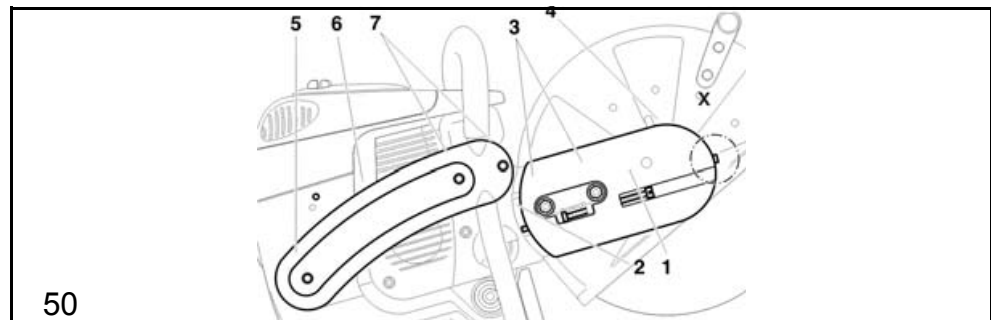

Loosen the nuts (3).

Loosen the tension screw (1) (counterclockwise) until you see the screw end (2) in the gap.

Release the screw (detail X, only on BTS 1140L3) and remove it.

Unscrew the nuts (3) and remove the cap (4).

Unscrew the screws (5) and (7) and take off the side brace (6).



NOTE:

Screw (5) is longer than screws (7). Observe the installation position during assembly!

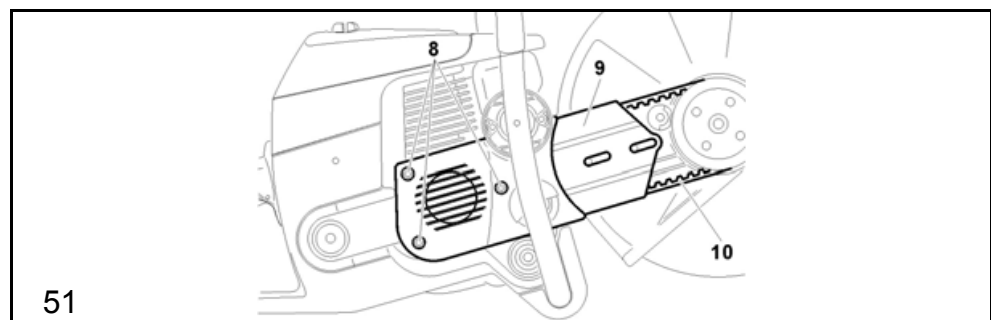

Loosen the screws (8) and take off the crankcase cover (9).

Remove the old V-belt (10) or any leftover V-belt material. Clean the inside of the transmission with a small brush.

Insert the new V-belt.

NOTE:

Mount the crankcase cover (9), the side brace (50/6) and the cover (50/4) in the reverse order.

Tighten the V-belt, see Chapter "**Tightening the V-belt/Checking the tension**".

8.2 Cleaning the protective hood

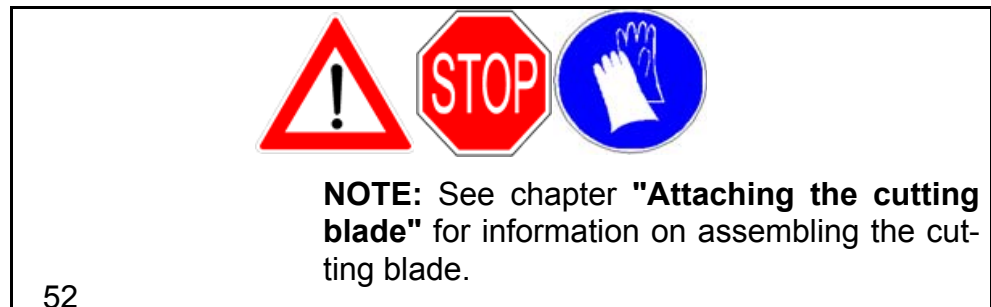

With time, material deposits will form on the inside of the protective hood (particularly when wet cutting). Under certain circumstances, these deposits can hinder the free rotation of the cutting blade.

Detach the cutting blade and thrust washer and remove the material deposits on the inside with a wood strip or similar tool.

Wipe off the shaft and all disassembled parts with a clean cloth.

8.3 Cleaning/Changing the air cleaner



NOTICE:

Before cleaning the air cleaner, turn off the engine! Never clean the air cleaner with compressed air! Do not clean the prefilter or the internal filter with fuel!

The engine's service life depends on the condition and the regular maintenance of the filter elements. Not regularly cleaning or maintaining the engine leads to excessive wear!

Replace a damaged air cleaner immediately! Torn pieces of fabric and large dirt particles can destroy the engine. If possible, do not work in dusty conditions! The particulate matter generated when dry cutting concrete and stone endangers the operator's health and shortens the engine's service life. If possible, carry out cutting operations for concrete and stone with water to bind dust particles together.

Maintenance work

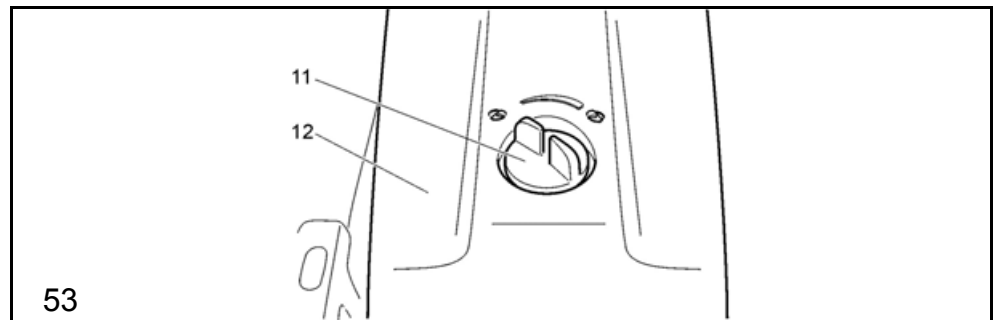

Turn the cover lock (11) to the "unlocked" position and carefully remove the filter cover (12).

Two sealing rings (54/15) are located between the filter cover (12) and the hood (54/14).

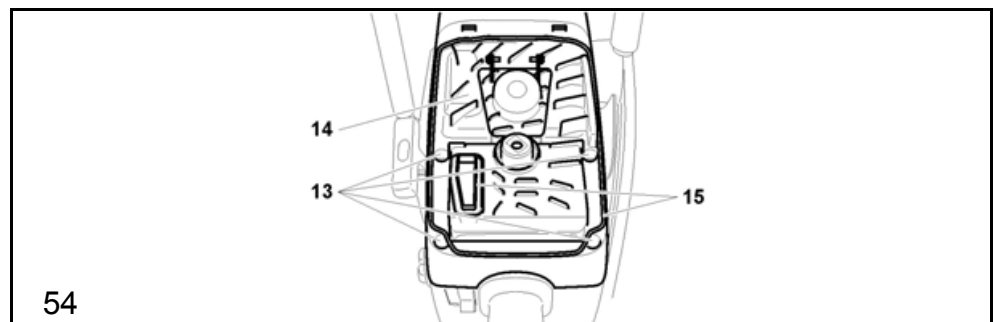

Loosen the screws (13) and take off the hood (14).

Clean the sealing rings (15) using a small brush and check for signs of damage.

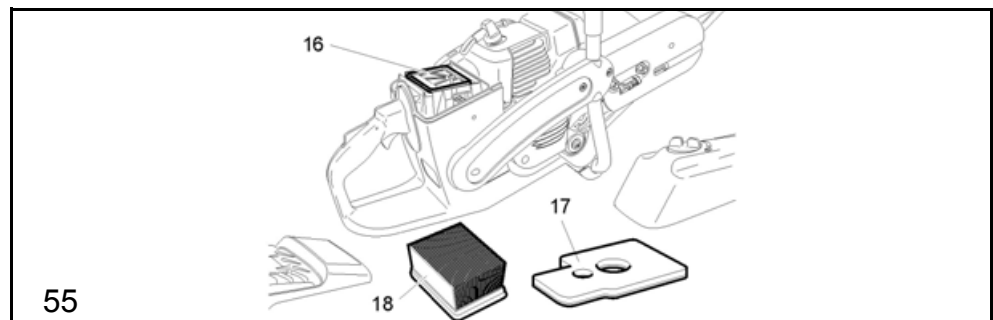

Take the prefilter (17) out of the filter cover.

Pull the air cleaner cartridge (18) out of the hood.

Take the internal filter (16) off the suction head.

Note:

Protect the carburetor to prevent dirt from falling into it!

Put the multifunction switch in the "Choke" position or cover the carburetor with a clean cloth.

8.4 Prefilter, air cleaner cartridge and internal filter

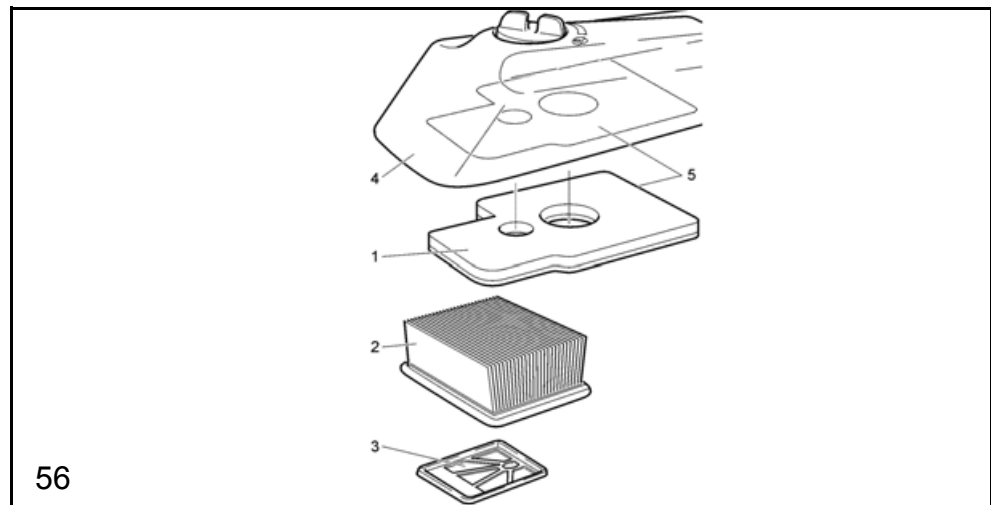

Prefilter (dry foam) (all models except for BTS 1140L3)

Wash out the dirty prefilter (1) in warm soap water using household dish washing detergent or filter cleaner. Do not clean the prefilter with fuel!

Rinse away dirt under running water.

Work 1 cap of filter cleaner into the prefilter foam into a good lather.

Rinse the prefilter under running water.

Dry the prefilter well.

NOTE: The prefilter must be cleaned daily; if an unusual amount of dust is produced, several times a day. If it is not possible to clean the prefilter on site, have a reserve prefilter ready. Renew the prefilter after ever 25 hours of operation at the latest.

Align the prefilter with the cover holder when inserting it into the filter cover, then press it into the filter cover (5). The prefilter must be flush with the cover holder in all areas and pressed in tightly.

Maintenance work

Prefilter (foam with air cleaner oil) (only BTS 1140L3)

Replacement (after cutting with excessive dust formation):

- daily
- or at least after 4 hours of operation
- or at least after filling the tank 8 times
- or at least after using 8 liters of fuel mixture

Replacement (after wet cutting/after cutting steel):

- weekly
- or at least after 25 hours of operation
- or at least after filling the tank 50 times
- or at least after using 55 liters of fuel mixture

Knead the foam air cleaner in the packaging prior insertion to ensure distribution of the oil. Remove the packaging afterwards.

Align the prefilter with the cover holder when inserting it into the filter cover, then press it into the filter cover (5). The prefilter must be flush with the cover holder in all areas and pressed in tightly.

Internal filter (all models)

Wash out the dirty internal filter (3) in warm soap water using household dish washing detergent or filter cleaner.

Air cleaner cartridge (all models)

NOTICE:

The air cleaner cartridge (2) filters the intake air through fine paper filter lamella. Thus never wash out the cartridge or clean it with compressed air.

Clean the air cleaner cartridge once a week.

Expand the lamella of the air cleaner cartridge slightly, lay it on a clean pad and carefully tap against it.

Replace the air cleaner cartridge after every 100 hours of operation. Replace it immediately if you notice a drop in power, a drop in engine speed or smoke in the exhaust fumes.

Before assembling the filter system, check whether dirt particles have fallen into the air intake port. If necessary, remove the dirt particles.

Maintenance work

8.5 Replacing the spark plug



NOTICE:

Do not touch the spark plug or spark plug connector while the engine is running (high voltage).

Carry out maintenance work only when the engine is off.

Hot engine can cause burns. Wear protective gloves!

The spark plug must be replaced if the ceramic insulator is damaged, or if the spark plug electrodes are severely burned, very dirty or oily.

NOTICE: Use only BOSCH WSR 6F, CHAMPION RCJ-6Y or NGK BPMR 7A spark plugs as replacements.

Using unapproved spark plugs can damage the ignition system.

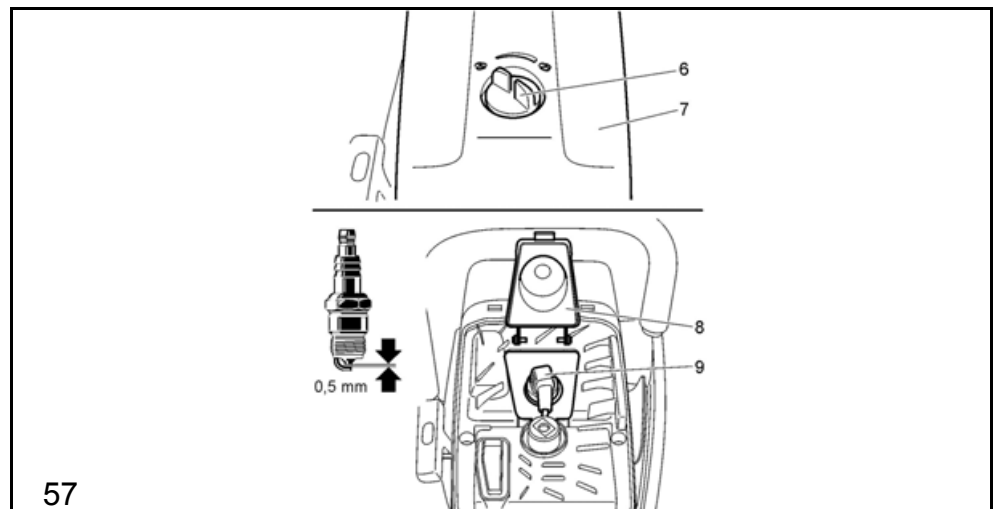

Turn the cover lock (6) to the "unlocked" position and carefully remove the filter cover (7).

Lift up the spark plug cover (8). Pull off the spark plug cap (9) from the spark plug. Remove the spark plug with the combination wrench included in delivery.

Spark plug air gap

The spark plug air gap must be 0.5 mm (0.020").

8.6 Checking the ignition spark

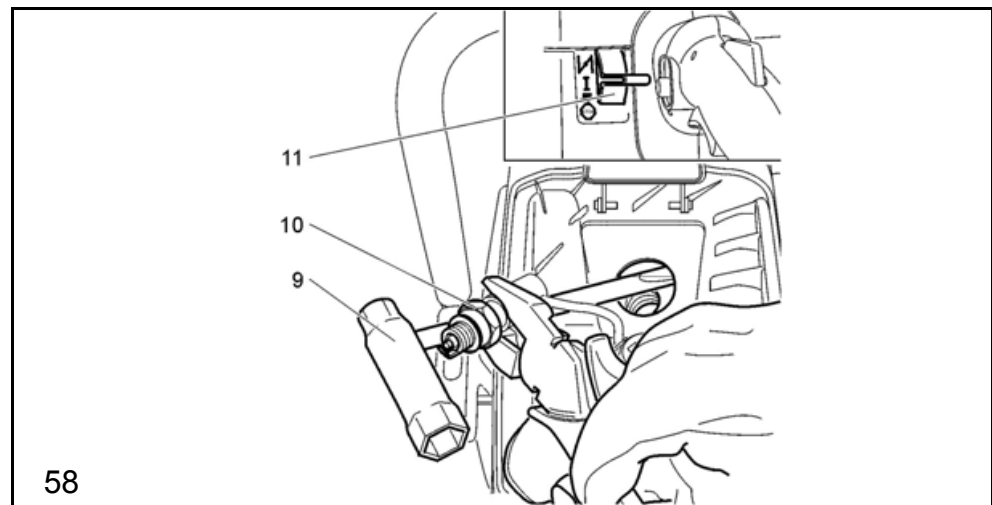

Insert the combination wrench (9) between the hood and cylinder, as shown in the figure.

NOTICE!

Do not insert the wrench into the spark plug hole; just make contact with the cylinder (otherwise you may damage the engine).

Press the unscrewed spark plug (10), with the spark plug terminal cap firmly attached, against the wrench using insulated pliers (away from the spark plug hole!).

Press the multifunction switch (11) to the "I" position.

Pull out the starter rope firmly.

If the spark plug is functioning properly, you must see a spark plug between the electrodes.

Maintenance work

8.7 Replacing the suction head

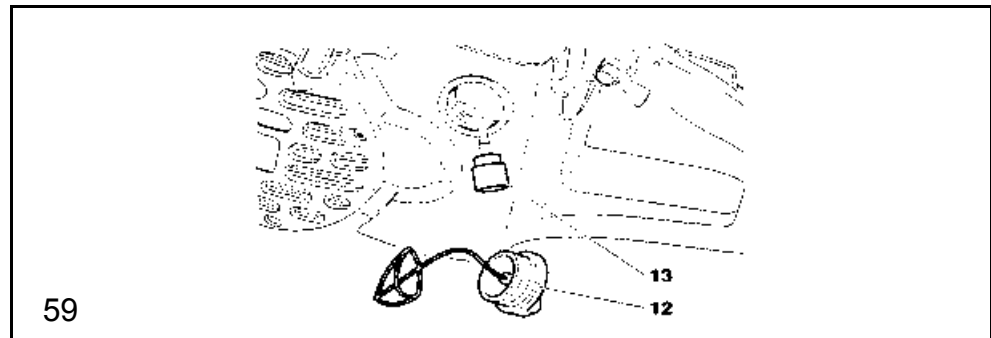

The felt filter (13) of the suction head can become clogged during operation. To ensure an unrestricted flow of fuel to the carburetor, the suction head should be replaced about every 3 months.

Unscrew the fuel tank cap (12), pull the retainer out of the tank opening.

Empty the tank.

To change it, pull the suction head through the tank cap opening using a wire hook.

Notice: Avoid skin and eye contact with mineral products!

8.8 Replacing the starter rope

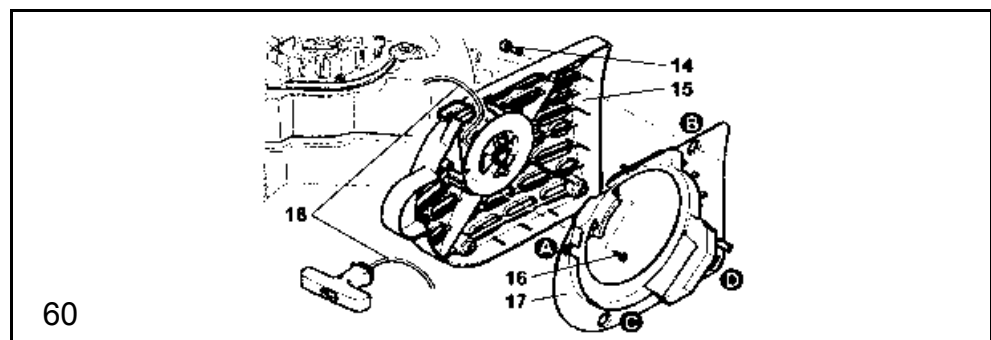

Release the four screws (14). Remove the valve housing (15).

Unscrew the two screws (16) and carefully disconnect the air horn (17) from the valve housing (15). Always proceed in the order (A - B - C - D).

Remove any leftover rope (18).

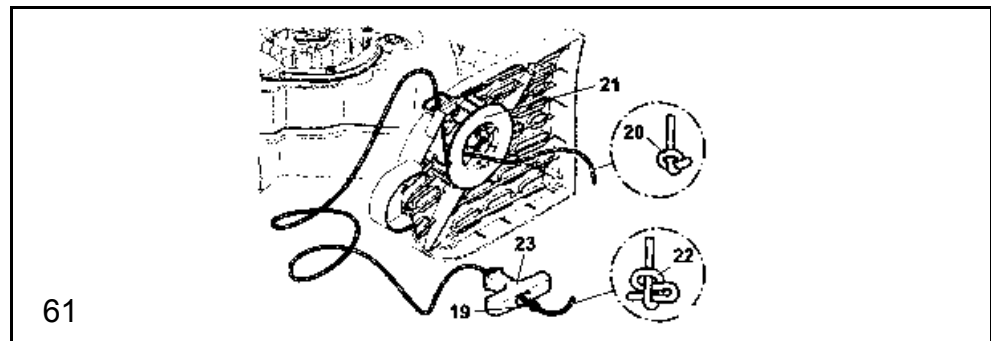

Feed in new rope with a diameter of 4.0 mm (0.16") and a length of 1,000 mm (40"), as in the illustration (do not forget the disc (19)) and knot both ends.

Pull the knot (20) into the rope drum (21).

Notice: Neither the knot nor the end of rope should extend beyond the surface of the rope drum.

Pull the knot (22) into the recoil starter handle (23).

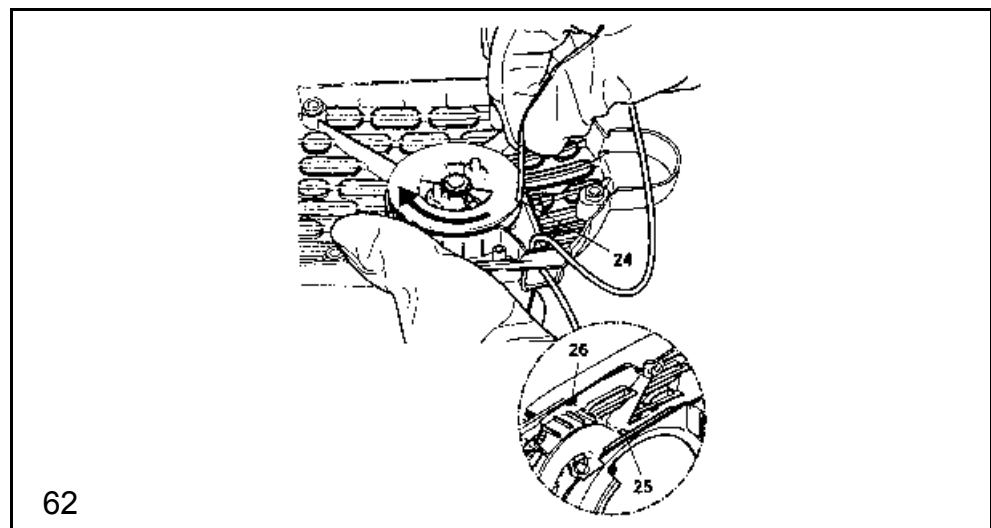

Pass the rope through the recess (24) on the rope drum and, together with the rope, turn the rope drum twice in the direction of the arrow.

Hold the rope drum firmly with your left hand, untwist the rope with your right hand, pull the rope taut and hold it tightly.

Carefully release the rope drum. The spring tension will cause the rope drum to wind up the rope.

Repeat the procedure **three times**. Now the recoil starter handle should now be in the upright position on the valve housing.

NOTE: When the starter rope has been fully extended, it must be possible to continue turning the rope drum at least a quarter of a turn against the spring tension.

Maintenance work

NOTICE! Danger of injury! Hold the extended recoil starter handle securely. It will recoil quickly if you accidentally let go of the rope drum.

Mount the air horn in reverse order (see Fig. 63). Make sure that the guide (25) is positioned in the receptacle (26) on the valve housing.

When attaching the valve housing pull the recoil starter handle lightly, if necessary, until the starting device engages.

8.9 Replacing the return spring

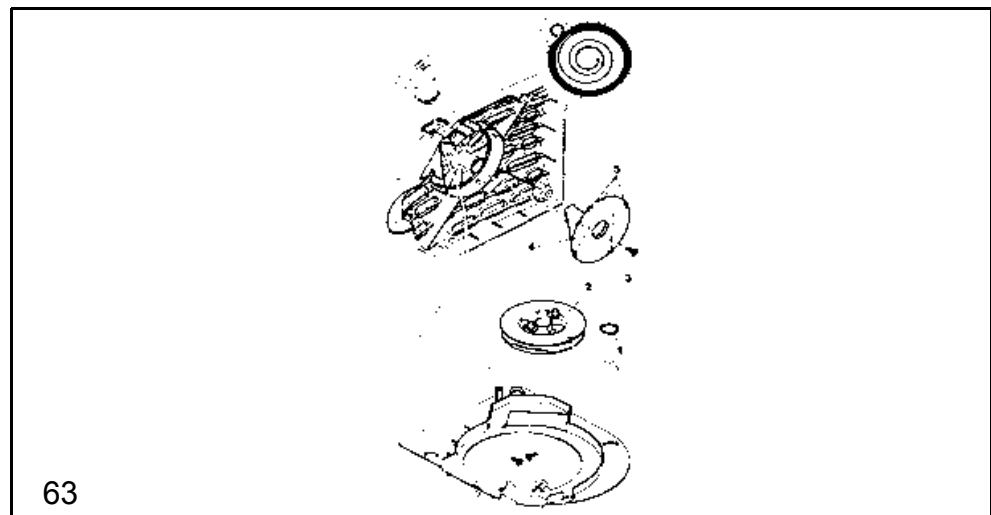

Remove the valve housing (see chapter "Replacing the starter rope"). Disconnect the air horn from the valve housing (see chapter "Replacing the starter rope").

Remove the retaining clip (1) (see the section on accessories for information about the pliers for external retaining clips).

Pull off the rope drum (2).

Remove the screws (3).

Pry the return spring (4) evenly off the latches by using a screwdriver or similar tool. **Exercise extra caution. The return spring is under tension and can suddenly spring out of the cassette!**

NOTICE: Danger of injury! Always wear safety glasses and wear protective gloves when performing this procedure!

Maintenance work

Replacement return springs are delivered already under tension in the housing. **CAUTION. The spring can snap out.** A released spring can be reinserted as in the illustration (**Make sure to note the rotation direction!**)

Apply a light coat of multipurpose grease to the new return spring (4) before you install it in the valve housing. Insert the return spring (4) and press gently against it so that the tabs (5) snap into the holders. Screw in the screw (3) and tighten only slightly. When attaching the rope drum, turn it slightly until it you feel it snap into place. Mount the retaining clip. Wind up the starter rope (see chapter "Replacing the starter rope"). Do not lubricate the rope drum (2) or the journals!

Attach the air horn (see chapter "Replacing the starter rope"). When attaching the valve housing pull the recoil starter handle lightly, if necessary, until the starting device engages.

8.10 Cutting attachment in the center/outer position

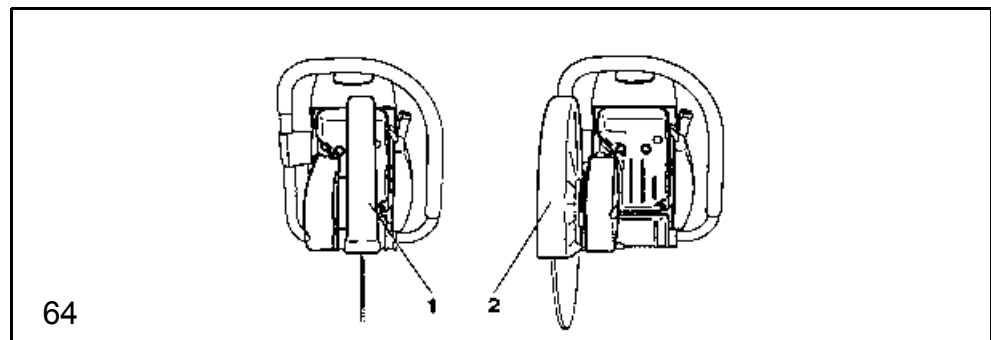

NOTE: The cutting attachment is mounted at the factory for operation in the center position (1). The cutting attachment can be mounted in the outer position (2) to maneuver around obstacles that are very close to the cutting line (for curbs, or brick walls). Use the outer position for guiding the cut-off saw by hand only for the work at hand. Afterwards, mount the cutting attachment back to the center position. A cut-off saw with the cutting attachment in the center position has a better center of gravity, which helps prevent early fatigue.

Maintenance work

8.11 Remounting the cutting attachment

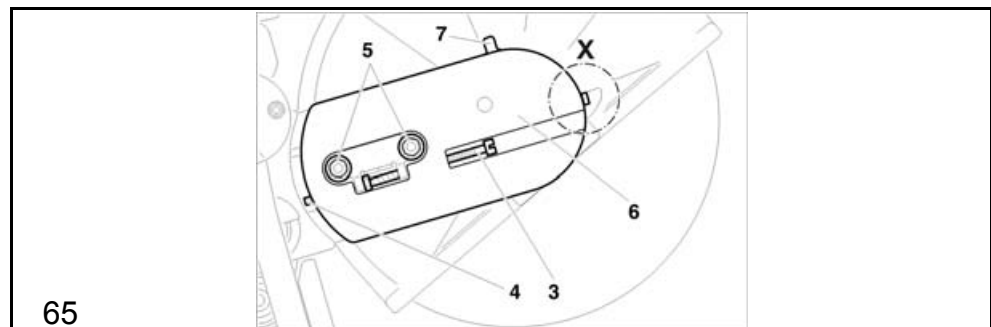

Loosen the nuts (**5**).

Loosen the tension screw (**3**) (counterclockwise) until you see the screw end (**4**) in the gap. Release the screw (detail **X**, only on BTS 1140L3) and remove it. Unscrew the nuts (**5**) and remove the cover (**6**).

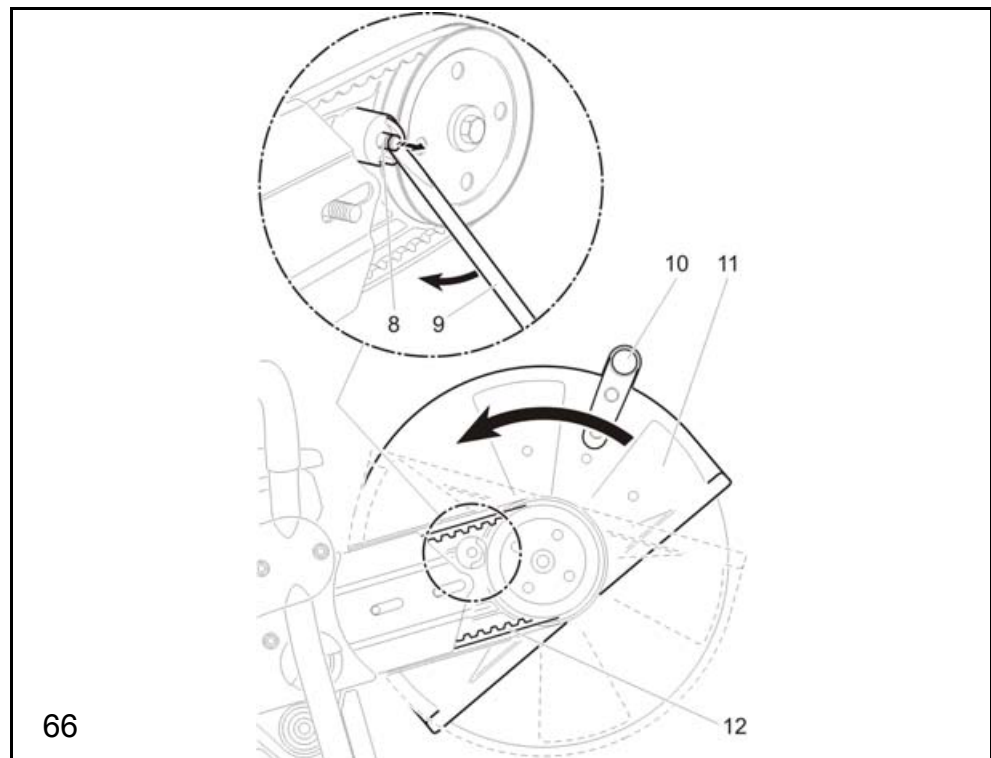

Pry out the stop pin (**8**) with the combination wrench (**9**) far enough, as shown in the figure, so that you are able to turn the protective hood (**11**).

Maintenance work

NOTE: When the stop pin (8) has been pulled out, the rotary stop (7) is deactivated. This makes it possible to turn the protective hood (11) beyond the rotary stop (7).

Unscrew the handle (10) and turn the protective hood (11), as shown in the figure.

Detach the V-belt (12) and remove the cutting attachment.

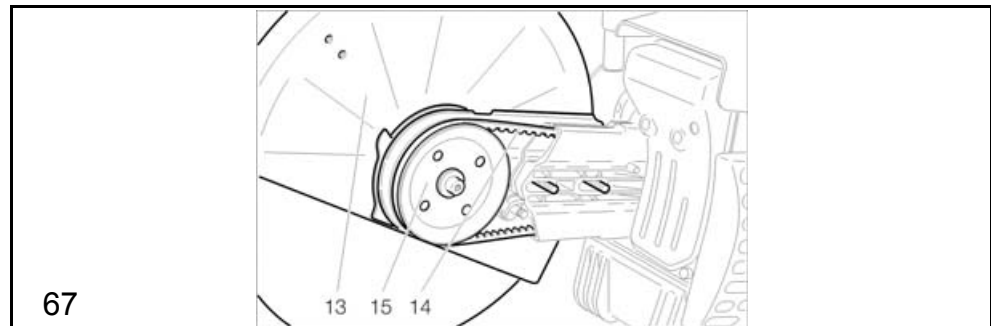

Press the cutting attachment (13) to the outer position against the gear arm receptacle.

Guide the V-belt (14) over the V-belt pulley (15).

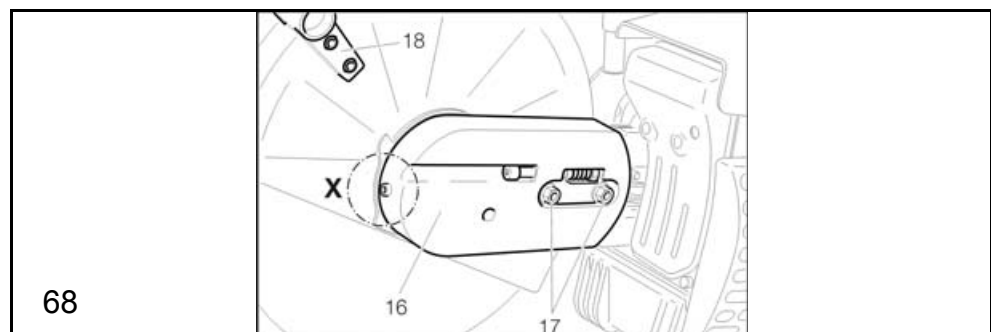

Place the cover (16) on top.

Screw on the nuts (17) and tighten by hand.

Tighten the V-belt, see Chapter "Tightening the V-belt/Checking the tension".

Screw in the screw (detail X, only on BTS 1140L3) and tighten it.

Tighten the nuts (17) securely with the combination wrench.

Reattach the handle (18) as in the illustration.

NOTICE:

Each time you modify the cutting attachment, this will change the cutting blade's direction of rotation!

Diamond-edged cutting blades must be mounted according to the direction of rotation!

Maintenance work

8.12 Periodic maintenance and service instructions

The maintenance work described below must be regularly carried out in to ensure a long service life, prevent damage and ensure that the safety devices function properly. Warranty claims will only be authorized if this work is carried out properly when scheduled. Non-compliance can cause accidents!

Users of cut-off saws are only permitted to carry out the maintenance and care procedures described in this operator's manual. All other procedures may only be carried out by a WACKER service station.

General	Entire cut-off saw	Clean the outside and check for damage. If damage is discovered, have it repair by qualified personnel immediately.
	Cutting blade, clutch	Check on a regular basis for signs of damage and wear.
	Protective hood	Clean, check position.
Each time before startup	Cutting blade	Check for damage and whether the correct cutting blade is mounted for the application at hand.
	V-belt	Check the V-belt tension.
	Multifunction switch, safety switch, throttle lever	Functional check.
	Fuel tank cap	Check for leakage.
Daily	Prefilter	Clean (replace after every 25 hours of operation and more often if necessary).
	Idle speed	Check (cutting blade must not rotate).
Weekly	Starter housing	Clean to ensure a proper flow of cooling air.
	Starter rope	Check for damage.
	V-belt	Check for signs of damage and wear.
	Air cleaner cartridge	Clean (replace after every 100 hours of operation).
	Spark plug	Check and replace as needed.
	Muffler	Check it is clogged, check that the screws are tight.

Maintenance work

Quarterly	Suction head	Replace.
	Fuel tank	Clean.
	Bearing, clutch drum	Clean and regrease.
Storage	Entire cut-off saw	Clean the outside and check for damage. If damage is discovered, have it repair by qualified personnel immediately.
	Cutting blade	Disassemble and clean.
	Fuel tank	Empty and clean.
	Carburetor	Run empty.

Maintenance work

8.13 Troubleshooting

Malfunction	System	Observation	Cause
Cutting blade does not start	Clutch	Engine is running	Clutch is damaged.
Cutting blade rotates when engine is idling	Carburetor, clutch	Cutting blade is running	Idle setting incorrect, clutch is blocked.
Engine will not start or is hard to start	Ignition system	There is an ignition spark	Malfunction in the fuel supply, compression system, mechanical fault.
		No ignition spark	STOP switch was actuated, fault or short-circuit in the cable, spark plug connector or spark plug is defective.
	Fuel supply	Fuel tank is full	Choke is in the wrong position, carburetor is defective, suction head is dirty, fuel line is kinked or interrupted.
	Compression system	Inside the machine	Cylinder base gasket is defective, oil seals are damaged or the piston ring is damaged.
		Outside of the machine	The spark plug does not make an airtight seal.
	Mechanical faults	Starter does not engage	Spring in the starter is broken, broken parts within the engine.
Problems with warm start	Carburetor	Fuel in tank, there is an ignition spark	Carburetor setting is incorrect.
Engine starts, but goes out again immediately	Fuel supply	Fuel in the tank	Idle setting incorrect, suction head or carburetor is dirty. Tank venting is defective, fuel supply interrupted, cable is damaged, STOP switch is damaged, decompression valve.
Insufficient power	This may affect several systems	Machine runs in idle	Air cleaner is dirty, carburetor setting is incorrect, muffler is clogged, exhaust port in the cylinder is clogged.

9. Guide cart

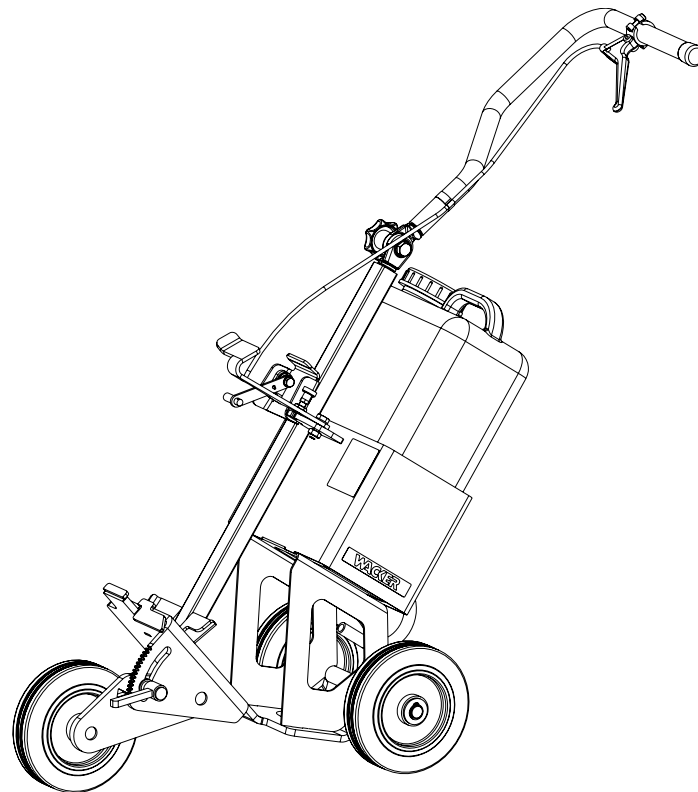

9.1 Application

The WACKER guide cart makes it easier to move the cut-off saw in a straight line. It allows operators to work without fatigue and can be adjusted based on body height. The cut-off saw can be operated with the cutting attachment in either the center or outer position.

Fitting the tank with an angular fuel tank filler neck is recommended when using the guide cart to make refueling easier.

The guide cart is equipped with a water tank and a water sprayer to bind dust particles together during the cutting process and to cool the cutting blade.

There are notches in the clamping lever to make it easier to set the cutting depth. One notch equals 10 mm cutting depth.

Guide cart

9.2 Safety information

- 9.2.1 The supports for the cut-off saw must be clean before inserting the BTS.
- 9.2.2 The notched bolt must be correctly locked to prevent the cut-off saw from coming loose while you are working.
- 9.2.3 Make sure that the clamping lever for setting the cutting depth and the star knob for adjusting the handle are tight during the cutting process.
- 9.2.4 In order to prevent malfunctions, the guide cart should be cleaned using water after each use.
- 9.2.5 During breaks or while in storage or transport place the machine on a flat foundation and secure it from rolling off or tipping over.
- 9.2.6 Immediately after completing the cutting process, bring the throttle lever into the idle position (forward).

10. Signs

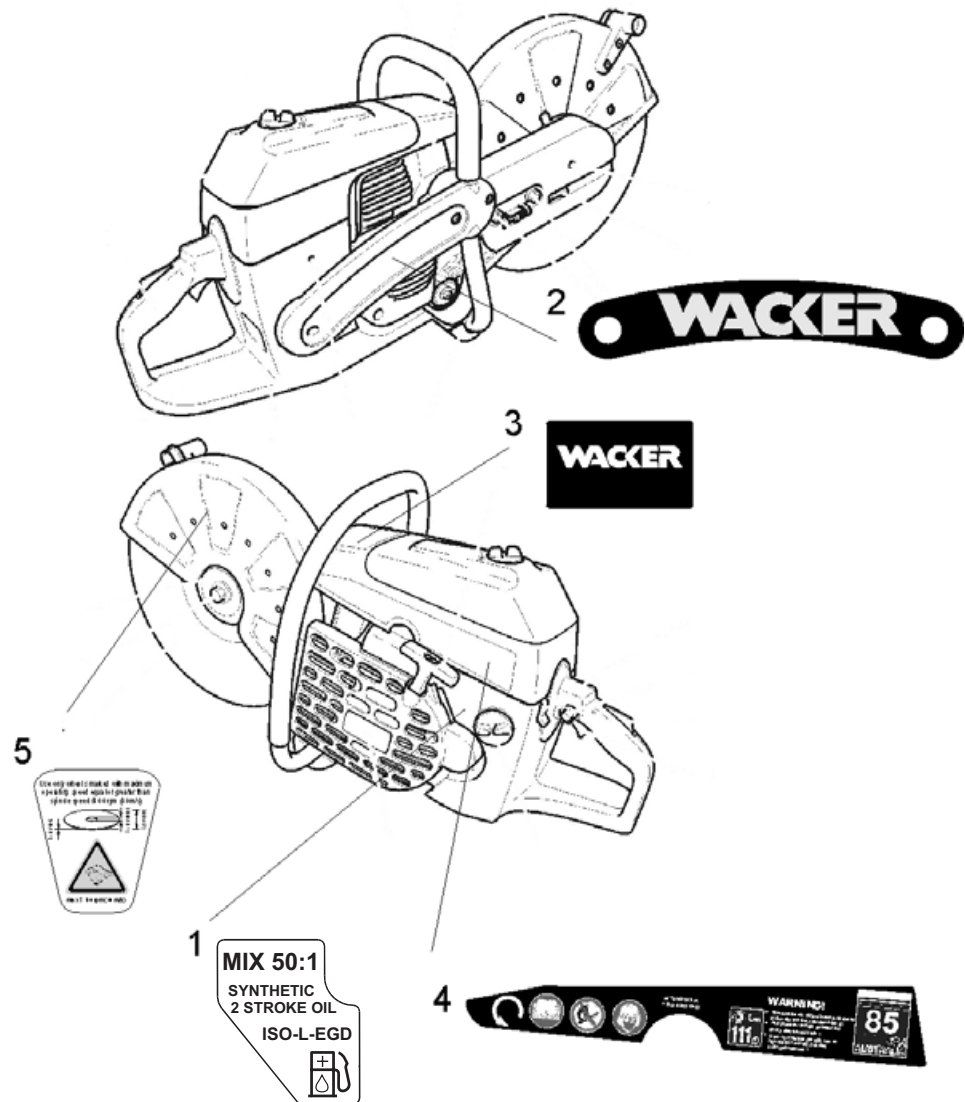

1	Gasoline/oil mixing ratio
2	WACKER Logo
3	Type
4	Safety hood
5	Safety protective hood

EC Declaration of Conformity

Wacker Construction Equipment AG, Preußenstraße 41, 80809 München

certifies that the construction machines:

Category

Cut-off saw

Type	BTS 930L3	BTS 935L3	BTS 1030L3	BTS 1035L3	BTS 1140L3
Machine type number	0008987 0610073	0008988 0610074	0008989 0610075	0008912 0008990 0610076 0610182	0610063 0610078

Type	BTS 930L3	BTS 935L3	BTS 1030L3	BTS 1035L3	BTS 1140L3
Absolute installed power	3.2 KW	3.2 KW	4.2 KW	4.2 KW	4.5 KW

were assessed in accordance with the directive 2000/14/EC.

Type	BTS 930L3	BTS 935L3	BTS 1030L3	BTS 1035L3	BTS 1140L3
Measured sound power level	109 dB(A)	109 dB(A)	110 dB(A)	110 dB(A)	108 dB(A)
Guaranteed sound power level	111 dB(A)				

were produced in accordance with the following directives:

2000/14/EC
89/336/EEC
98/37/EC

ppa Otto C

Dr. Stenzel
Head of Research and Development



VDE Prüf- und Zertifizierungsinstitut

VDE VERBAND DER ELEKTROTECHNIK
ELEKTRONIK INFORMATIONSTECHNIK e.V.

CERTIFICATE

Registration-Number: 6236/QM/06.97

This is to certify that the company

WACKER

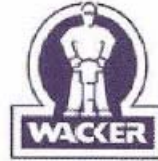

**Wacker Construction Equipment AG
Wacker-Werke GmbH & Co. KG**

at the following locations

**Head Office Munich
Preußenstraße 41
80809 Munich**

**Production plant Reichertshofen
Karlsfeld logistics centre
Sales regions with all branches all over Germany**

has implemented and maintains a
Quality Management System for the following scope:

**Machine manufacture
Construction machines**

This Q System complies with the requirements of

DIN EN ISO 9001:2000

and the requirements of the German and international Road Traffic Act.

This Certificate is valid until 2009-06-05.

VDE Testing and Certification Institute
Certification

Date: 2006-05-30

63069 Offenbach, Merianstraße 28
Telefon: +49 (0) 69 83 06-0, Telefax: +49 (0) 69 83 06-555
E-Mail: vde-institut@vde.com, <http://www.vde-institut.com>



The VDE Testing and Certification Institute is accredited by DAR Accreditation
Bodies according to DIN EN ISO 17020 and DIN EN ISO 45012 and notified in the EU
under ID.No. 0366.

TGA-ZM-09-92-00
KBA-ZM-A 00021-97

995 704 759 (8.08 GB)