

OPERATING INSTRUCTIONS

DINO 260XTD

Manufacturer:

Dinolift Oy

Raikkolantie 145

FI-32210 LOIMAA

Tel. +358 20 1772 400

info@dinolift.com

www.dinolift.com

Dealer:

TRANSLATION OF THE ORIGINAL INSTRUCTIONS

Valid from serial number

260XTD 26419 -

CONTENTS

1.	TO THE OPERATOR	6
1.1.	OVERVIEW OF THE UNIT.....	7
1.2.	INTENDED USE OF THE WORK PLATFORM.....	7
2.	TECHNICAL SPECIFICATIONS	8
2.1.	DIMENSION DRAWING.....	10
2.2.	REACH DIAGRAM.....	11
2.3.	EXAMPLE OF THE MACHINE'S NAMEPLATE.....	12
2.4.	EXAMPLE OF EU DECLARATION OF CONFORMITY.....	13
2.5.	SAMPLE OF INSPECTION PROTOCOL FOR THE ACCESS PLATFORM.....	14
3.	SAFETY	16
3.1.	SAFETY INSTRUCTIONS.....	16
3.2.	SAFETY-RELATED NOTIFICATIONS.....	20
3.3.	SAFETY DEVICES.....	21
4.	STRUCTURE AND FUNCTIONS OF THE WORK PLATFORM	25
4.1.	STRUCTURE OF THE WORK PLATFORM.....	25
4.2.	FUNCTIONS OF THE WORK PLATFORM.....	26
4.3.	OPERATING CONTROLS FOR THE FUNCTIONS.....	27
4.3.1.	Operating controls in the chassis control centre LCB.....	27
4.3.2.	Operating the support outriggers from the chassis panel.....	28
4.3.3.	Operating controls in the platform control centre UCB.....	29
4.3.4.	Automatic levelling and electric control of the driving device – DCB centre (option)...	31
5.	OPERATING INSTRUCTIONS	32
5.1.	START-UP.....	32
5.1.1.	Worksite inspection.....	32
5.1.2.	Positioning the lift.....	33
5.1.3.	Starting the machine.....	34
5.1.4.	Supporting the lift.....	36
5.2.	OPERATION.....	38
5.2.1.	Operating the lift from the chassis control centre.....	38
5.2.2.	Operating the lift from the platform control centre.....	39
5.2.3.	Special instructions for winter use.....	41
5.2.4.	Ending the work.....	41
5.3.	TRANSFERRING THE LIFT.....	42
5.3.1.	Preparing the lift for transport.....	42
5.3.2.	Using the driving device.....	43
5.3.3.	Towing the lift.....	45
5.3.4.	Lifting the device.....	46
5.4.	LONG-TERM STORAGE.....	47

5.3.	IN CASE OF EMERGENCY	48
5.3.1.	When at risk of losing the stability	48
5.3.2.	In case of overloading.....	48
5.3.3.	In case the power supply is interrupted	48
5.3.4.	In case of malfunction, when even the emergency descent system is not operational	50
6.	INSTRUCTIONS FOR FAULT-FINDING	51
7.	MAINTENANCE SCHEDULE.....	55
7.1.	SCHEDULE FOR INSPECTIONS REQUIRED BY THE AUTHORITIES	57
7.2.	LUBRICATION PLAN	58
8.	ROUTINE MAINTENANCE DURING OPERATION	59
8.1.	INSTRUCTIONS FOR DAILY MAINTENANCE AND INSPECTIONS	60
8.1.1.	Check the condition of chassis, the boom and the work platform.....	60
8.1.2.	Check the tyres and tyre pressure.....	60
8.1.3.	Check the lights	60
8.1.4.	Check the hydraulic oil level	60
8.1.5.	Check the hydraulic hoses, pipes and connectors	60
8.1.6.	Check the operation of the safety limit switches.....	61
8.1.7.	Check the operating controls	61
8.1.8.	Check the operation of the emergency descent, the emergency stop and the sound signal	61
8.1.9.	Decals, stickers and signs	61
8.1.10.	Instruction manuals.....	61
9.	CHANGE OF OWNER.....	63

1. TO THE OPERATOR

Keep this manual on the work platform of the lift in the box reserved for it. If the instruction manual gets lost, damaged, or for some other reason becomes unreadable, order a new manual from the manufacturer.

This manual is intended to familiarise the user with the structure and functions of the work platform, as well as with its appropriate use. The manual provides guidance on the service measures that are the responsibility of the user of the work platform.

Other maintenance procedures on the work platform require special skills, special tools or accurate knowledge about measurements or adjusted values. Guidance for these measures is provided in a separate service manual. For situations that require service or repair measures, contact the authorised service provider, importer or manufacturer.



DANGER

Read all the instructions in this manual before using the aerial work platform. Make sure that you have understood all the instructions. The instructions must absolutely be followed during operation and maintenance of the aerial work platform.

When handling the unit, in addition to the instructions in this manual, the user must also observe the local legislation, the guidelines stipulated by the employer, and regulations valid at the work site.

Dinolift Oy is constantly developing its products. For this reason, the contents of this manual might not always be in full compliance with the most recent version of the product. Dinolift Oy reserves the right to modify the product without prior notice. Dinolift Oy assumes no liability for any problems caused by changed or missing data or mistakes in this manual.

Please consult your dealer or the manufacturer for more information and detailed instructions.

NOTICE

USA only

Dealers, installers, owners, users, operators, lessors, lessees and brokers must fulfill the responsibilities stated in the manual of responsibilities according to ANSI92.5 standard for boom-supported elevating work platforms.

1.1. OVERVIEW OF THE UNIT

This unit is a trailer mounted, towable aerial work platform.

It is an aerial work platform, which complies with the EN280 type 1, where travelling is only allowed with the platform in transport configuration.

For the operation the lift shall be supported by its hydraulic outriggers, extended so that the wheels of the trailer lift off the ground.

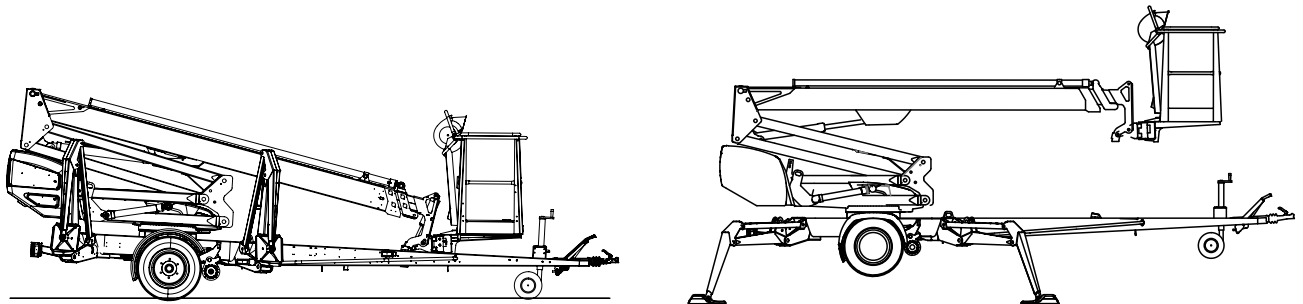

The primary power source of the lift is electric motor. The outriggers and the boom system are hydraulically powered.

As an option, the lifts can be equipped with a driving device that can be controlled from the ground.

Consult the chapters “Technical data” and “Structure and functions of the work platform” in this manual for more detailed information about the lift.

1.2. INTENDED USE OF THE WORK PLATFORM

The aerial work platform is exclusively intended for transferring people and tools and acting as a work platform within its permissible load-bearing capacity and reach (refer to the “Technical Specifications” table and the “Reach Diagram”).

The intended use also covers:

- Following all the instructions in the Operating Instructions
- Performance of the inspections and maintenance operations.

This aerial work platform is NOT insulated, and does not offer protection against contact with electric current. The aerial work platform must not be used for work on electric systems.

Observe the safety instructions concerning the operating environment, and the restrictions given in them,

NOTICE

The operator must receive instructions and consent from the manufacturer for all such specific work methods or conditions that the manufacturer has not explicitly defined in the unit's operation and maintenance instructions.

2. TECHNICAL SPECIFICATIONS

		260XTD
Max. working height		26,0 m
Max. platform height		24,0 m
Max. outreach		11,7 m
Boom rotation		continuous
Platform rotation		90°
Turn area		refer to the reach diagram
Support width		4,40 m
Transport width		2,05 m
Transport length		8,21 m
Transport height		2,43 m
Weight		3495 kg
Max. allowed load on platform		215 kg
Max. number of persons + additional load		2 persons + 55 kg
Max. allowed sideways load (caused by persons)		400 N
Max. lateral inclination (chassis)		±0,3°
Maximum allowed gradient of ground to the side		6,7°
Maximum allowed gradient of ground lengthwise		8,3°
Max. wind speed during operation		12,5 m/s
Min. ambient temperature when working		- 20 °C
Max. support force on the outriggers		22800 N
Platform size		0,8 x 1,8 m
Gradeability		25%
Socket outlets on the platform		2 x 230V/50Hz/16A
Power supply		
- mains current		230V/2,2kW / 50Hz/16A
	Sound pressure level	< 70 dB
	Whole-body vibration	Not detectable

Honda GX390SXE	
Fuel	Petrol
Net output	8,7 kW (11,7 h.p.)
Fuel tank volume:	6.5 l
Oil volume	1.1 l
Fuel consumption	230 g /HPh
Sound pressure level	101 dB
Whole-body vibration	< 0,5 m/s ²

Optional engines

Hatz 1B30	EPA / CARB Tier 4 Final
Fuel	Diesel
Net output	4.6 kW (6.2 hp)/ 3000 rpm
Oil volume	1.1 l
Sound pressure level	101 dB
Whole-body vibration	< 0,5 m/s ²

2.1. DIMENSION DRAWING

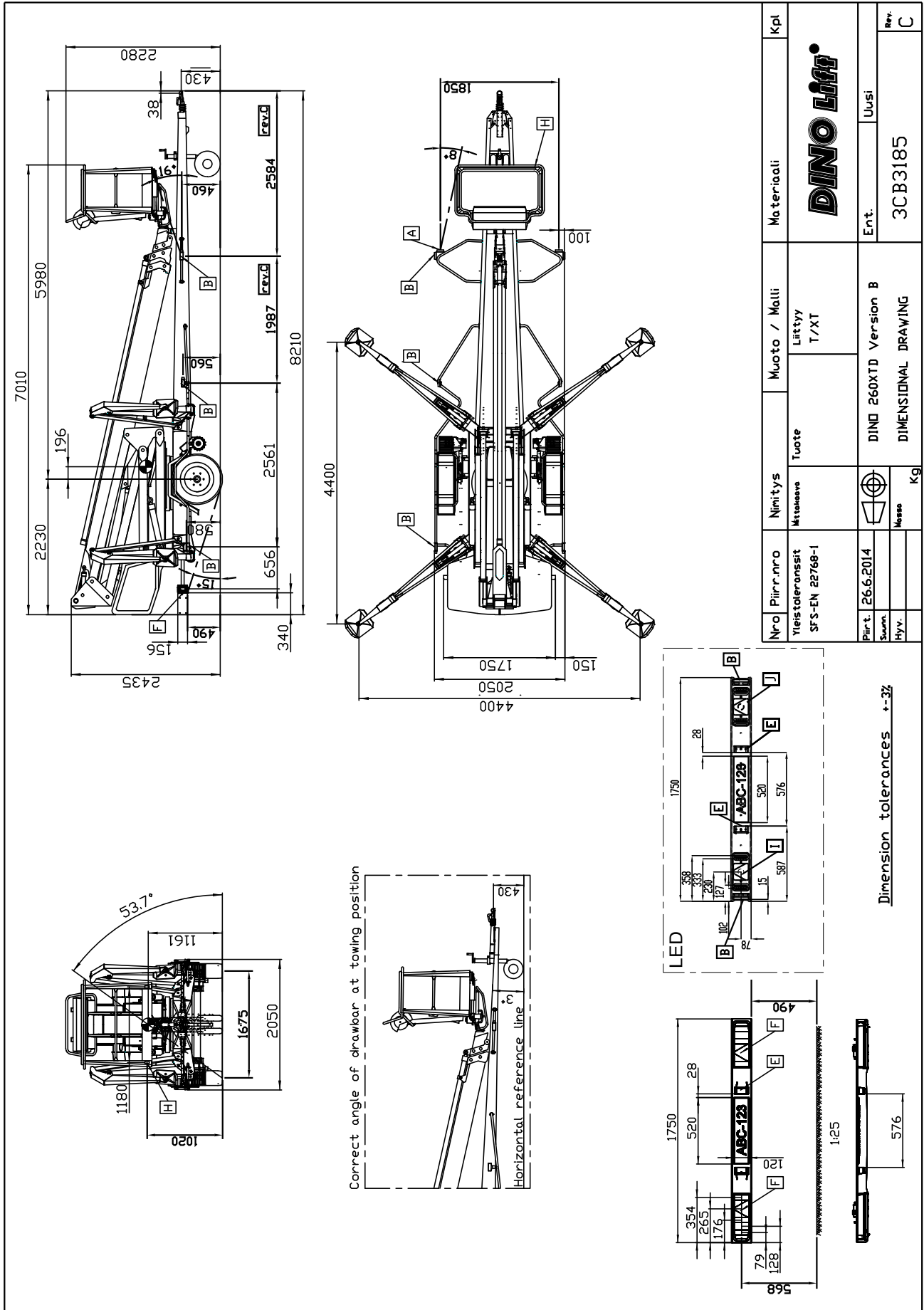

2.2. REACH DIAGRAM

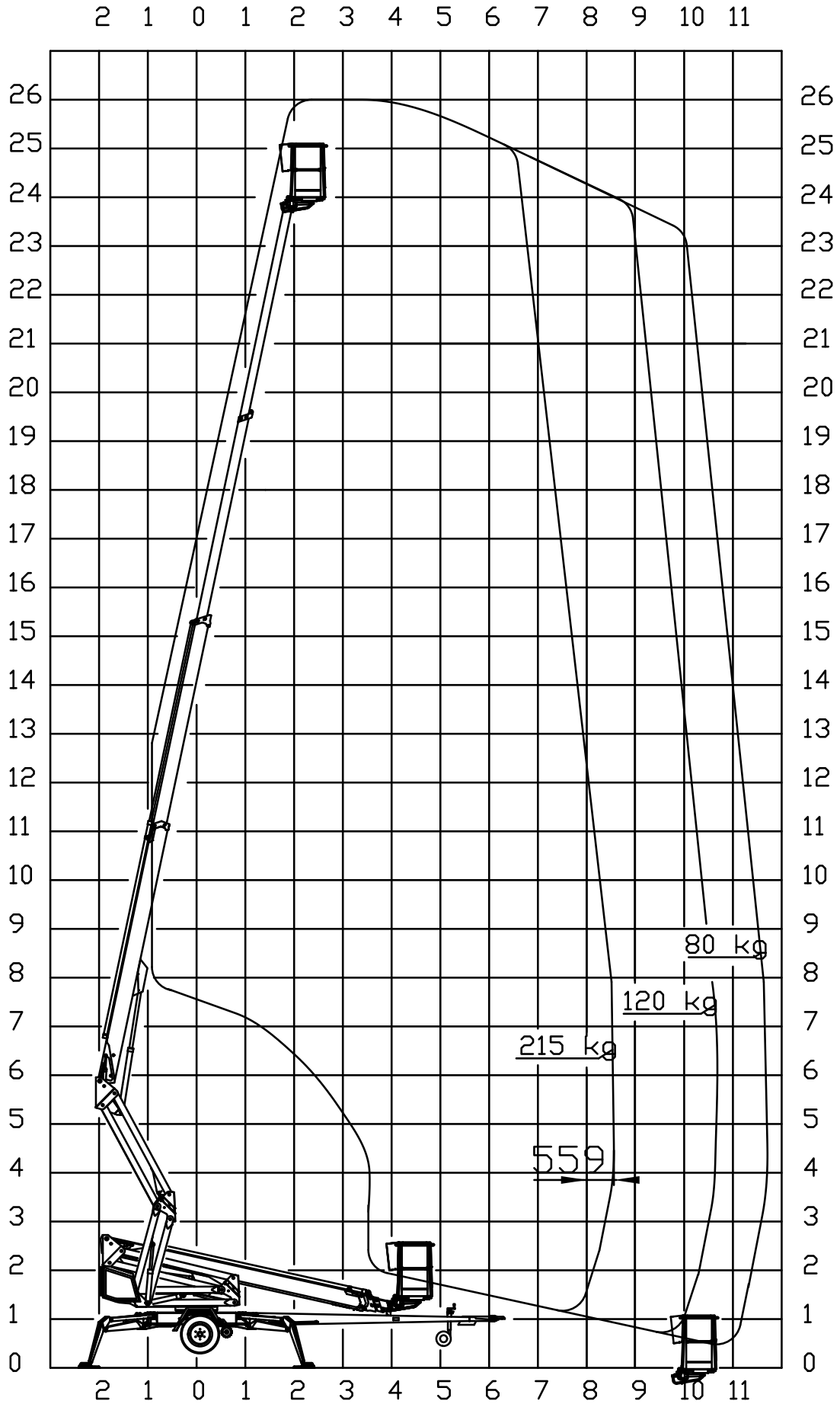

2.3. EXAMPLE OF THE MACHINE'S NAMEPLATE

The name of the manufacturer, and the production number and serial number of the machine have been marked on the nameplate as shown in the picture below.

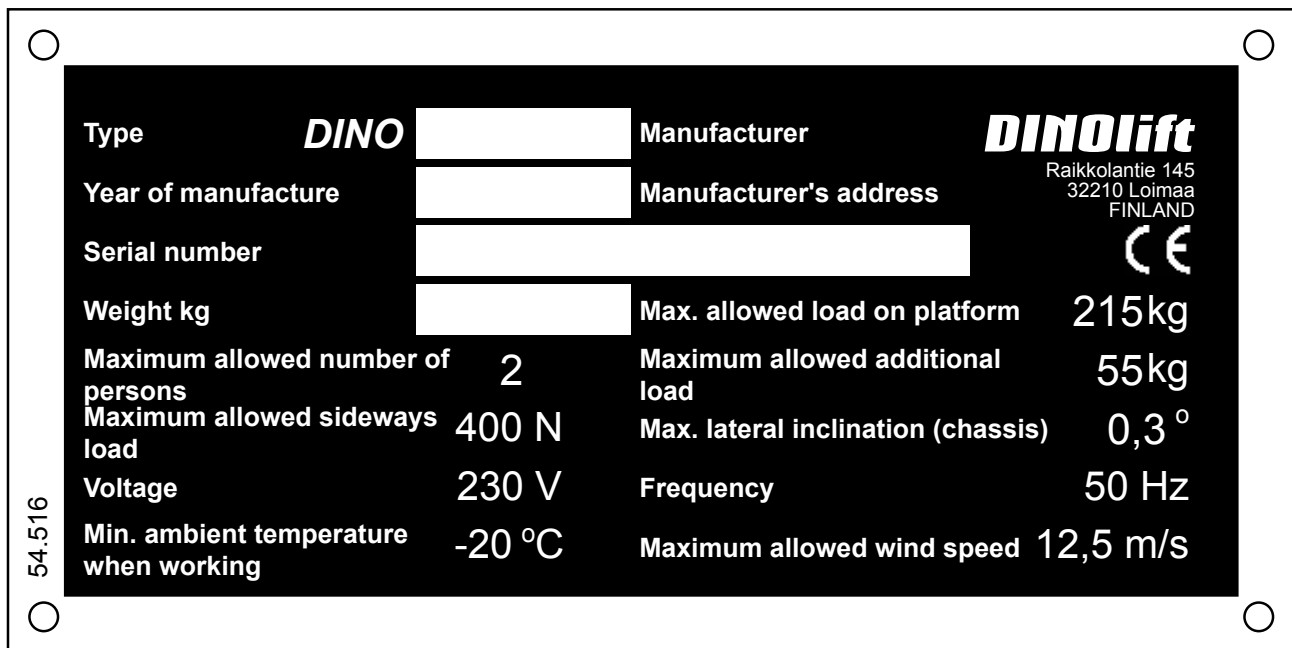

The nameplate of the lift is located on the right-hand side of the tow-bar, as shown in the picture.



The serial number is also engraved in the lift's chassis, on the upper surface of the right-hand tow-bar.



The nameplate of the trailer is located on the tow-bar, on the right-hand side of the nameplate of the lift, as shown in the picture.

Following data is written on the plate:

EU Type Approval Number (if available)		
Serial number		
	Total weight	kg
0	Maximum allowed weight on the towing hitch	kg
1	Maximum allowed axle weight	kg
2		kg

2.4. EXAMPLE OF EU DECLARATION OF CONFORMITY**EU declaration of conformity for machine****Manufacturer**

Dinolift Oy
Raikkolantie 145
FI-32210 Loimaa, FINLAND

declares that

DINO 260XTD Aerial Work Platform no YGCD260XTH0026498

conforms to the provisions of the Machine Directive 2006/42/EC
as well as the national decree (VNA 400/2008), through which they have been brought
into effect

The inspection in accordance with Annex IX to the directive 2006/42/EC has been
carried out by the notified body no. 0537,

VTT
P.O.Box 1300
FI-33101 Tampere, FINLAND

has granted the certificate no. **VTT 177/524/14**

In addition, the aerial work platform also complies with the provisions of the following
European Directives:

2014/35/EC, 2000/14/EC, 2014/30/EC

101 dB	Measured sound power level Petrol/Diesel L_{wa}	(99+1,5) 100,5 dB / (99,5+1,5)
	Guaranteed sound power level L_{wa}	100,5+0,5 dB / 101+0,5 dB

To the assessment procedure of conformity has been applied: 2000/14/EC, Annex V:
Internal control of production.

In designing the machine, the following harmonised standards have been applied:
SFS-EN 280:2013, SFS-EN 60204-1/A1, SFS-EN-ISO 12100

The person, who has compiled the technical construction file: Santtu Siivola
Chief Engineer
Dinolift Oy, Raikkolantie 145,
FI-32210 Loimaa, FINLAND

Loimaa 12.05.2017

Santtu Siivola
Chief Engineer

2.5. SAMPLE OF INSPECTION PROTOCOL FOR THE ACCESS PLATFORM

TEST CERTIFICATE

DATE: |

START-UP TESTS:

Inspection place: Dinolift Oy

Inspector's signature: |

Schmidt Florian NT0578-2

BASIC INFORMATION

Manufacturer: Dinolift OY

Place of manufacture: Finland

Address: Raikkolantie 145
32210 LOIMAA

Importer:

- | | | | |
|---------------|-------------------------------------------------------|--------------------------------------------|-----------------------------------------------------------------|
| Type of lift: | <input checked="" type="checkbox"/> Boom platform | <input type="checkbox"/> Scissor platform | <input type="checkbox"/> Mast platform |
| Chassis: | <input type="checkbox"/> Car | <input type="checkbox"/> Self propelled | <input checked="" type="checkbox"/> Trailer mounted |
| Boom: | <input type="checkbox"/> Articulated boom | <input type="checkbox"/> Telescopic boom | <input checked="" type="checkbox"/> Articulated telescopic boom |
| | <input type="checkbox"/> Fixed mast | <input type="checkbox"/> Telescopic mast | <input type="checkbox"/> Scissor |
| Outriggers: | <input checked="" type="checkbox"/> Hydraulic turning | <input type="checkbox"/> Hydraulic pushing | <input type="checkbox"/> Mechanical |

TECHNICAL SPECIFICATIONS

Machine and type:	<u>DINO 260XTD</u>	Max. platform height:	<u>24 m</u>
Number of manufacture:		Max. outreach:	<u>Depend on load</u>
Year of manufacture:			
Max. lifting capacity:	<u>215 Kg</u>	Boom rotation:	<u>Continuous</u>
Max. person number:	<u>2 hlö</u>	Support width:	<u>4,4 m</u>
Max. additional load:	<u>55 Kg</u>	Transport width:	<u>2,04 m</u>
Power supply:	<u>230VAC / Engine</u>	Transport length:	<u>8,25 m</u>
Lowest temperature:	<u>-20 °C</u>	Transport height:	<u>2,33 m</u>
Weight:	<u>3495 kg</u>	Basket size:	<u>0,7x1,3 m</u>

INSPECTION POINTS: (Y = meet standards N = do not meet standards)

	Y	N		Y	N
A. GENERAL REQUIREMENTS			C. STRUCTURES		
1. Suitability for use	<input checked="" type="checkbox"/>	<input type="checkbox"/>	1. Transport position / transp. equipment	<input checked="" type="checkbox"/>	<input type="checkbox"/>
2. Certificate of conformity	<input checked="" type="checkbox"/>	<input type="checkbox"/>	2. Driving/towing equipment	<input checked="" type="checkbox"/>	<input type="checkbox"/>
3. User manual and storage	<input checked="" type="checkbox"/>	<input type="checkbox"/>	3. Chassis	<input checked="" type="checkbox"/>	<input type="checkbox"/>
4. Machine plate - inspection plate	<input checked="" type="checkbox"/>	<input type="checkbox"/>	4. Turning device	<input checked="" type="checkbox"/>	<input type="checkbox"/>
5. Instructional and safety plates	<input checked="" type="checkbox"/>	<input type="checkbox"/>	5. Boom system	<input checked="" type="checkbox"/>	<input type="checkbox"/>
6. Safety colours	<input checked="" type="checkbox"/>	<input type="checkbox"/>	6. Structure and position of work platform	<input checked="" type="checkbox"/>	<input type="checkbox"/>
			7. Hydraulic system	<input checked="" type="checkbox"/>	<input type="checkbox"/>
B. STABILITY			D. ELECTRIC SYSTEM		
1. Load plate and reach diagram	<input checked="" type="checkbox"/>	<input type="checkbox"/>	1. Electric system	<input checked="" type="checkbox"/>	<input type="checkbox"/>
2. Supports / outriggers	<input checked="" type="checkbox"/>	<input type="checkbox"/>	2. Electric appliances	<input checked="" type="checkbox"/>	<input type="checkbox"/>
3. Indicator for horizontal position	<input checked="" type="checkbox"/>	<input type="checkbox"/>	3. Lights	<input checked="" type="checkbox"/>	<input type="checkbox"/>

<p>E. SAFETY AND CONTROL DEVICES</p> <p>1. Safety limit switches <input checked="" type="checkbox"/> <input type="checkbox"/></p> <p>2. Sound signal <input checked="" type="checkbox"/> <input type="checkbox"/></p> <p>3. Emergency descent system <input checked="" type="checkbox"/> <input type="checkbox"/></p> <p>4. Protection of controls <input checked="" type="checkbox"/> <input type="checkbox"/></p> <p>5. Symbols / control directions <input checked="" type="checkbox"/> <input type="checkbox"/></p> <p>6. Placement of controls <input checked="" type="checkbox"/> <input type="checkbox"/></p> <p>7. Emergency stop <input checked="" type="checkbox"/> <input type="checkbox"/></p>	<p>F. SAFETY FEATURES</p> <p>1. Prevention of unauthorized use <input checked="" type="checkbox"/> <input type="checkbox"/></p> <p>2. Locking device, covers and guards <input checked="" type="checkbox"/> <input type="checkbox"/></p> <p>3. Prevention of lifting <input checked="" type="checkbox"/> <input type="checkbox"/></p> <p>4. Prevention of opening of support <input checked="" type="checkbox"/> <input type="checkbox"/></p> <p>5. Safety distances <input checked="" type="checkbox"/> <input type="checkbox"/></p> <p>8. Control of loading <input checked="" type="checkbox"/> <input type="checkbox"/></p> <p>9. Limiting devices <input checked="" type="checkbox"/> <input type="checkbox"/></p> <p>G. TEST LOADING</p> <p>1. Overload test (150%) 323 kg <input checked="" type="checkbox"/> <input type="checkbox"/></p> <p>2. Functional test (110%) 237 kg <input checked="" type="checkbox"/> <input type="checkbox"/></p>
<p>FAILINGS AND NOTES _____</p>	
<p>Failings have been repaired. Date: _____ Signature: _____</p>	

The initial inspection and test loading of the Dino aerial work platforms is performed by the manufacturer. A protocol, drawn up during the inspection, will accompany the lift.

The protocols of the start-up and periodic inspections must be kept with the lift or its immediate proximity for at least five years.

3. SAFETY

All the essential safety instructions and warnings, relevant to transport, use and maintenance of the lift, are described in this chapter.



DANGER

Failure to observe these instructions and safety regulations may cause a severe injury or even death. Familiarise yourself with all the safety regulations, operating instructions and signs affixed to the machine, and follow them.

Make sure that you understand all the safety instructions and regulations. Also make sure that others operating the machine or working on the work platform are familiar with these instructions.

3.1. SAFETY INSTRUCTIONS

Only specially trained personnel with authorisation in writing, who are well familiarised with the device, and at least 18-years old, are allowed to operate the unit.

Keep the lift free of any dirt, which may impair safe operation, and impede the inspection of the structures.

The device must be serviced and inspected regularly.

Only skilled persons, familiar with the service and repair instructions for the lift, are allowed to carry out servicing and repair work.

It is strictly prohibited to use a lift which is out of order.

Never remove or disable any safety devices of the machine.



WARNING

The device must neither be altered without the manufacturer's consent nor be used under conditions, which do not meet the manufacturer's requirements.

The operator must be given instructions and consent from the manufacturer for all such specific work methods or conditions that the manufacturer has not explicitly defined.

TRANSFERS

Observe the maximum allowed gradient when transferring the lift. During transfer in rough terrain, always try to position yourself higher than the machine.

Beware of fixed or moving obstacles in the terrain or near the lift while driving. Make sure that you have a clear view of the driving path.

WORK AREA AND PREPARATIONS BEFORE LIFTING WORK

When working in busy areas, the operating range of the lift must be clearly marked by using either warning lights or fencing.

Also observe the regulations of the Road Traffic Act.

Ensure the unobstructed range of movement before operating the outriggers.

The load-bearing capacity and the gradient of the base must be taken into account when supporting the chassis.

Ensure that the outriggers cannot slide while on a gradient.

Additional support plates of adequate size must be used under the outriggers, when working on soft ground. Only use such additional support plates, on which the metallic outriggers will not slide.

While in the support position, ensure that the wheels are off the ground.

Always verify the horizontal position of the machine.

Always ensure that the work area is clear of outsiders. Danger of getting squeezed between rotating and fixed structures.

While operating the boom from the control centre on the turning device, beware of getting pressed against the outriggers or other structures that do not turn with the boom.

LIFTING AND WORKING ON THE PLATFORM

Never exceed the maximum number of persons, maximal loading or lateral force, allowed for the lift. Never add load onto the platform while in the upper position.

Before operating, always ensure that the safety devices and the emergency descent system are in working order.

Never use a lift alone. Make sure that there is always someone on the ground, who can call for help in case of an emergency.

Use the safety harness! Fix the safety harness to the fixing points, intended for the purpose.

Note! The platform is fitted with a fixing point for the safety harness of each user. Only one harness per fixing point.

Do not use ladders, steps or other similar equipment on the platform.

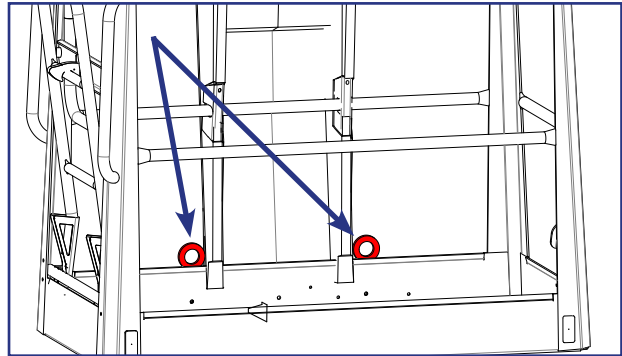

Never throw or drop any objects from the platform.

The lift must not be used as a crane.

The lift must not be used for transferring goods or persons between different floors or working levels. Stepping on or off the platform in motion is prohibited.

When the boom is in its lowest positions, make sure it cannot clash during rotation with structures that do not turn with the boom.

Always make sure, before lowering the platform, that the area under it is clear.

Avoid damaging the platform by lowering it on the ground, or bringing it in contact with any structures.

OPERATING CONDITIONS

The weather conditions, such as wind, visibility and rain, must always be taken into account so that these will not adversely affect the safe performance of the lifting operations.



The use of the lift is prohibited, if the temperature drops under -20 °C or the wind speed exceeds 12.5 m/s

Wind speed (m/s)		Conditions on land
0	Calm	Smoke rises vertically
1-3	Light breeze	Smoke moves with the wind and the wind feels on exposed skin. Leaves rustle.
4-7	Gentle breeze	Leaves and small branches of trees are moving. Flag is flying. Wind lifts dust and loose pieces of paper from the ground.
8-13	Strong breeze	Small broad-leaved trees and large branches sway. Wind whistles as it hits houses or other fixed objects. Umbrella is difficult to use.
14-16	Strong	All the trees are swaying. It is difficult. to walk against the wind.

Do not take tools/material of large surface area onto the platform. The increase in wind load may jeopardize the stability of the device.

Beware of the live aerial power lines in the area – observe the minimum safety distances:

Voltage range (Phase to phase)	Minimum approach distance	
	Meters	Feet
0 - 300 V	Avoid contact	
300 V - 50 kV	3	10
50 kV - 200 kV	4,5	15
200 kV - 350 kV	6	20
350 kV - 500 kV	8	25
500 kV - 750 kV	11	35
750 kV - 1000 kV	14	45

These distances shall apply unless more stringent limits are given in worksite instructions or in local or governmental regulations.

This unit is NOT insulated, and does not offer protection against contact with electric current. The aerial work platform must not be used for work on electric systems.

3.2. SAFETY-RELATED NOTIFICATIONS

The following safety alert symbols and safety signal words are used in this manual.

Observe all the safety instructions that follow these symbols, in order to avoid dangerous situations and personal injuries.



This is a general safety alert symbol and it is used to alert you about a potential hazard. Observe the additional instructions given in form of text or symbols that follow this symbol.



DANGER

Red DANGER-message warns for an imminent or potential hazardous situation which, if not avoided, may result in death or serious injury.



WARNING

Orange WARNING -message is used in connection with potential risk factors, which if not avoided, under certain conditions, may result in death or serious injury.



CAUTION

Yellow CAUTION -message is used to warn about a hazardous situation which, if not avoided, could result in minor or moderate injury.

NOTICE

Blue notice-message is used to draw your attention to special notifications or instructions that are related to the operation or maintenance. Such messages include, for example, instructions that are related to reliability of the machine or aim to avoid material losses.

3.3. SAFETY DEVICES

1. Supervision of transport position of the boom

The safety limit switch RK3 prevents the operation of the outriggers and the driving device when the boom is not resting on the transport support. The switch is located on the tow-bar at the transport support.

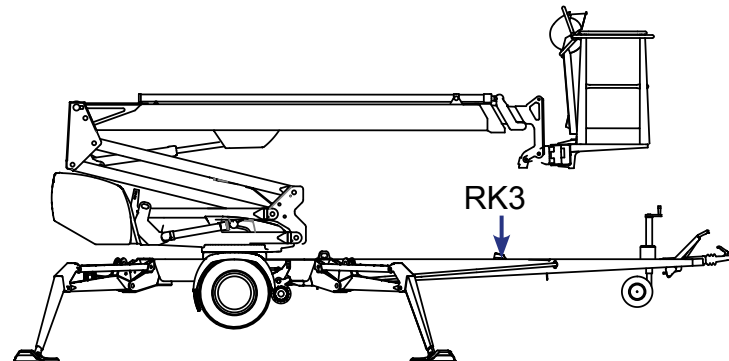

2. Supervision of supporting

The lift's all support outriggers must be in the support position before the boom is lifted. Make sure that the wheels are off the ground.

The safety limit switches RK11, RK12, RK13 and RK14 are located on the support outriggers.

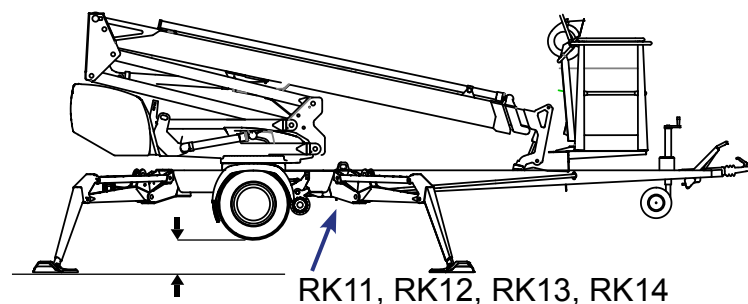

3. Overload control of the boom

The outreach limit switch RK4 and overload limit switch RK5 prevent the lift from being overloaded by limiting the outreach of the lift to the side.

The limit switches are located under the cover at the top end of the lifting cylinder. During operation, the cover must be intact and in place.

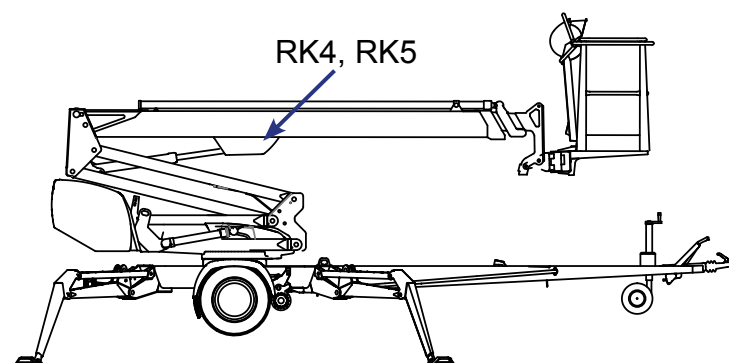

Operating instructions • DINO 260XTD

The green light in the control centre on the platform is lit, when the platform is within the allowed operating range.

The reach limit switch **RK4** will stop the movements, which impair the stability of the lift (extending the telescope and lowering the boom), at a predetermined position.

Adjusted values of the limits:

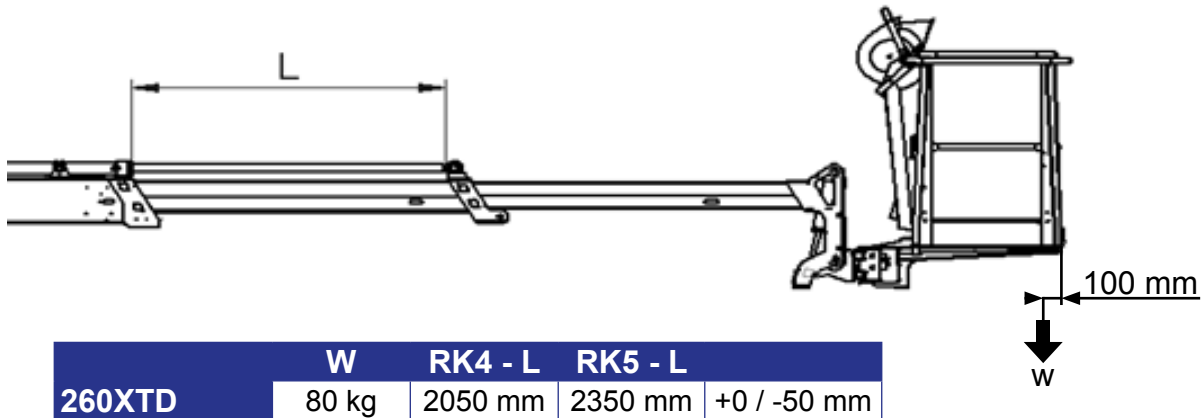

The red warning light for overloading will illuminate as soon as the **RK4** has stopped the movement. While at the outreach limit, the red warning light and the green signal light will flash in turns. In this situation, the lift can be operated in the direction, in which it remains inside the permitted outreach area.

The overload limit switch **RK5** backs up, if the **RK4**, for some reason, does not work. Once the **RK5** is activated, the red warning light for overloading in both control centres will be continually illuminated, and a warning buzzer will sound on the platform.

The operation of the overload limit switches is based on monitoring of the boom's lifting torque.

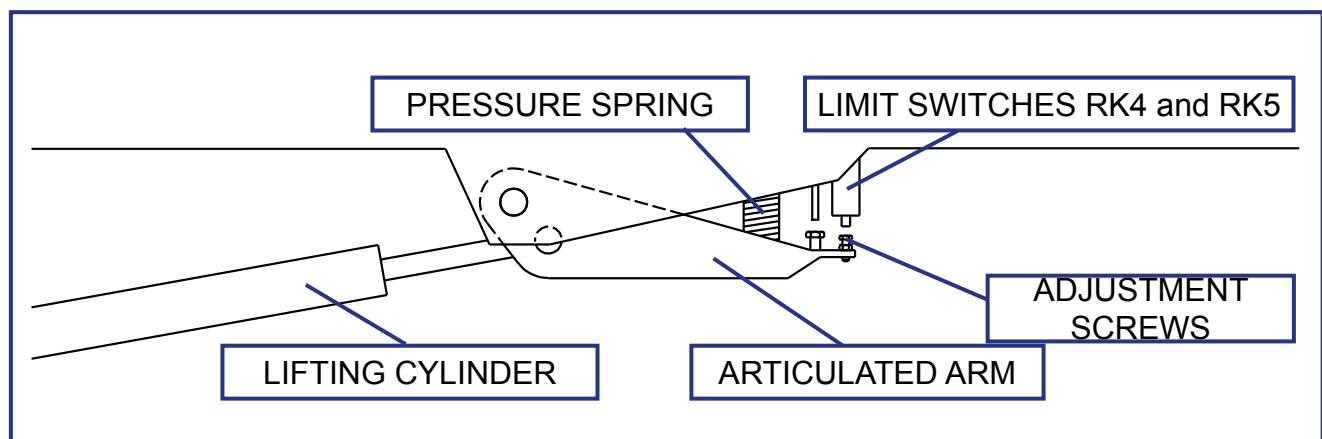

DANGER

The limit switches must never be readjusted, nor the operation of the mechanism be impeded. **Risk of turning over the lift!**

5. Supervision of the telescope chain

The extension chains for the telescope are doubled.

If the load-bearing chain slackens or breaks, the doubling chain prevents the movements of the telescope, and the safety switch RK7/RK15 breaks the emergency stop circuit.

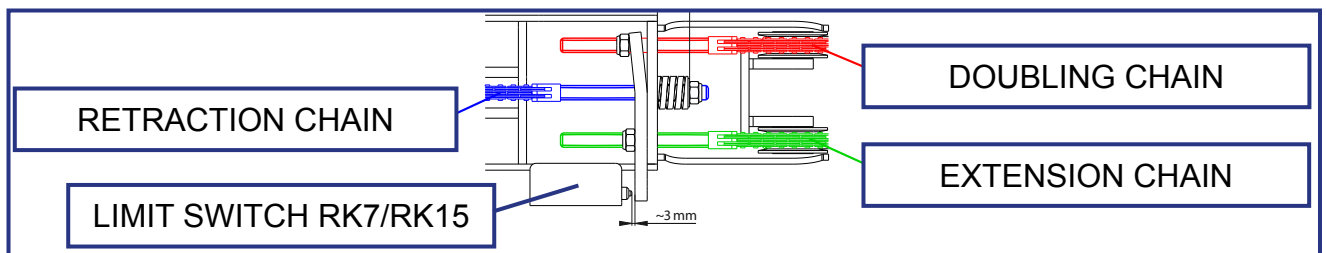
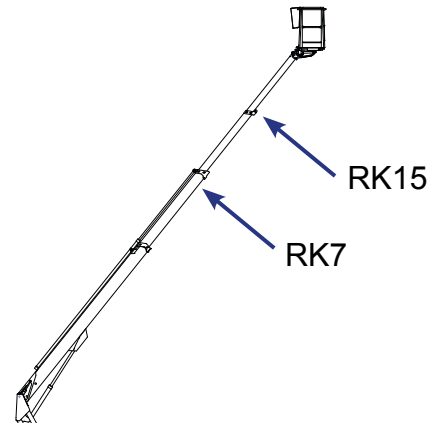

6. Preventing the inclination of the platform

The platform is levelled hydraulically by means of a so-called slave cylinder system, where the master cylinder controls the slave cylinder that inclines the work platform.

The platform keeps its level position only if the valves in the system are tight.

The levelling system comprises the following parts:

- Master cylinder
- Slave cylinder
- Load regulation valve
- Double load regulation valve

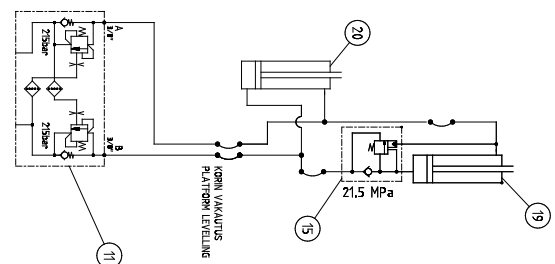

7. Safety devices for hose rupture

All the load-bearing cylinders are equipped with valves for rupture or leak in the hydraulic system, which prevent the load from falling.

Outrigger cylinders	Lock valves	Prevent the inching of the outriggers in either direction.
Lifting cylinder of the boom	Load regulation valve	Prevents the load from falling
Lifting cylinder of the articulated arms	Load regulation valve	Prevents the load from falling
Telescope cylinder	Load regulation valve	Prevents the inching of the telescope in either direction.
Levelling system	Load regulation valves	Prevents the inclination of the platform

7. Emergency stop buttons

Depressing the emergency stop button, stops all the movements immediately and turns off the power unit. The button can be found at each control station. Once the button has been depressed, only the emergency descent functions remain operational.

The emergency stop button locks in the lower position, and it must be released before starting the power unit.

NOTICE

If the unit does not start, make sure that the emergency descent button is not in the lower position at any of the control stations.

The emergency stop button in the platform control centre is fitted with a signal light, which remains illuminated while the lift is in the normal operating mode. The light will go out, if the emergency stop function is activated by any of the emergency stop switches or by the safety device.

4. STRUCTURE AND FUNCTIONS OF THE WORK PLATFORM

The denominations of the machine's essential parts and concepts, which are used later in these instructions, are described on the following pages.

4.1. STRUCTURE OF THE WORK PLATFORM

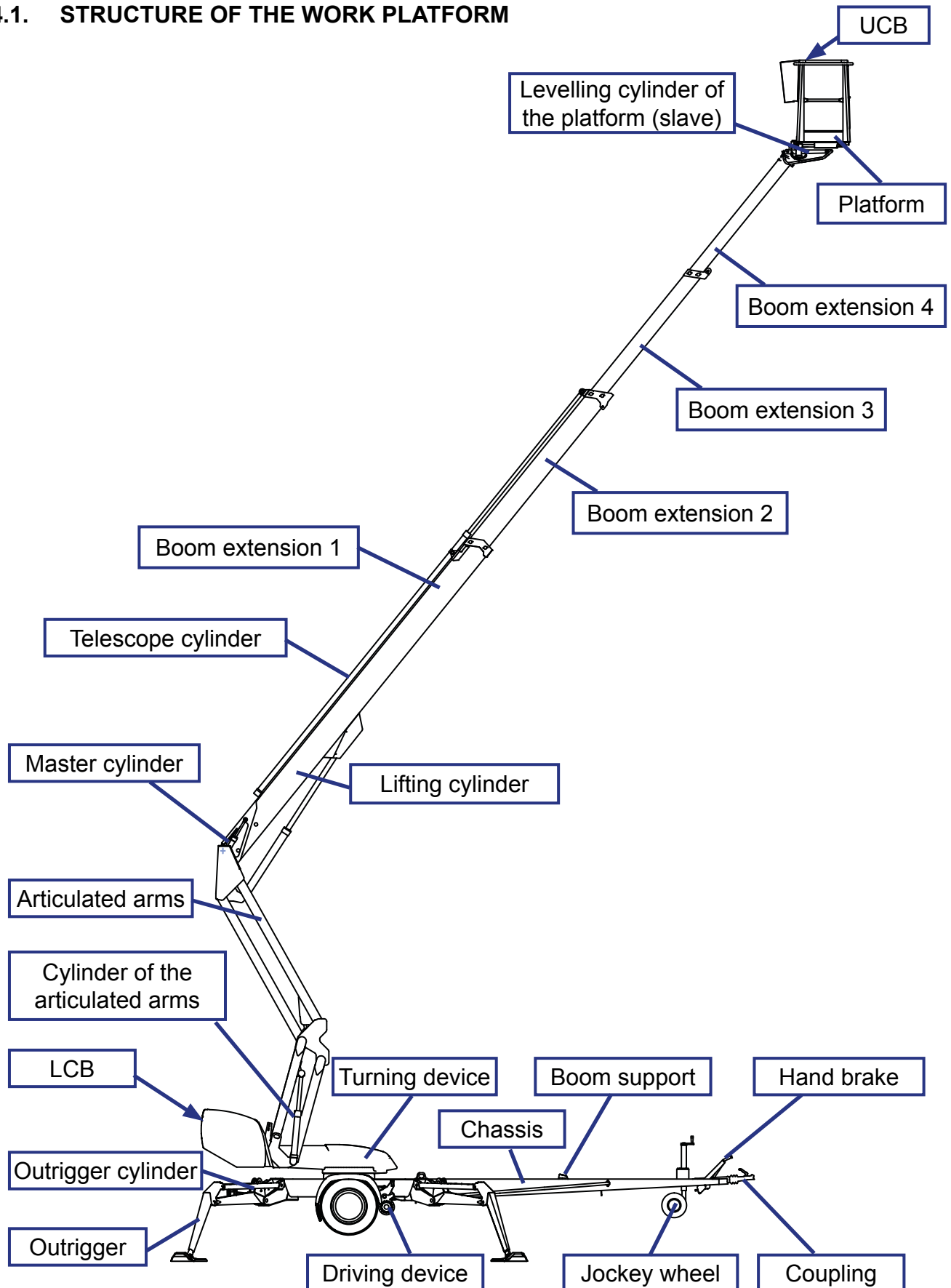

4.2. FUNCTIONS OF THE WORK PLATFORM

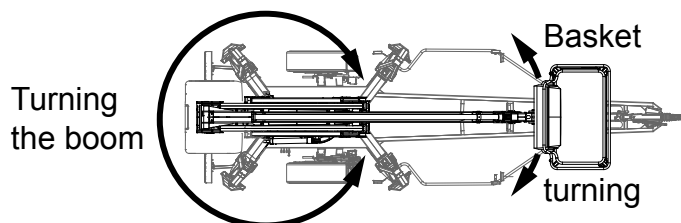
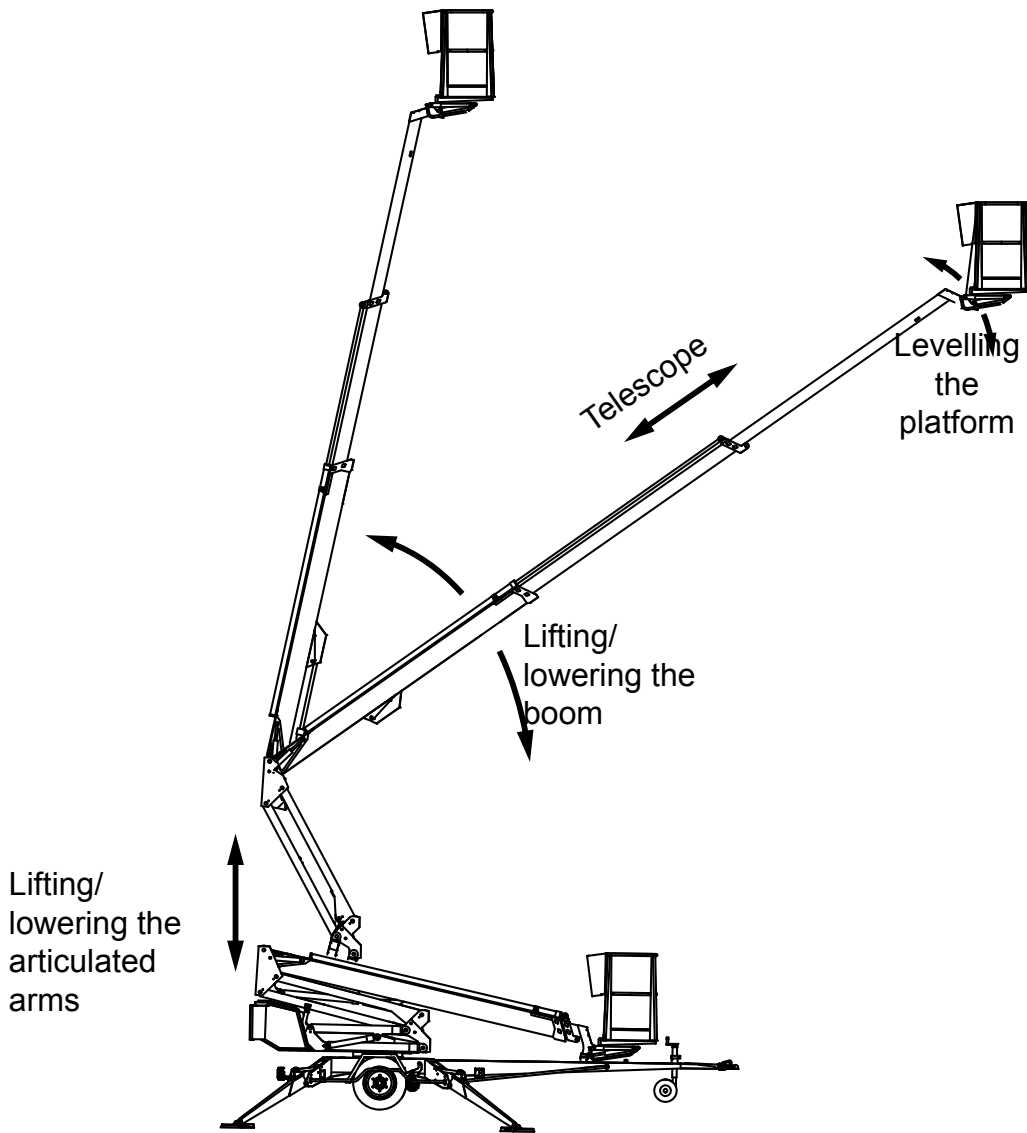
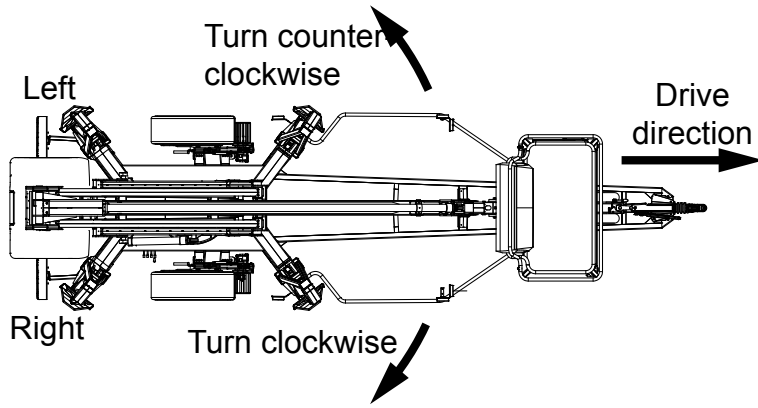

4.3. OPERATING CONTROLS FOR THE FUNCTIONS

4.3.1. Operating controls in the chassis control centre LCB

Q1	Selector switch	S1	Emergency stop
S6	Start and stop switches for the engine	S11	Start button for emergency descent system
S8	Selection of boom speed	S31	Pushbutton for retracting the telescope
S9	Choke		
S16	Lever switch for turning	H8	Signal light for safety device (RK5)
S17	Lever switch for boom system	VM1	Mains current gauge
S18	Lever switch for telescope		
S19	Lever switch for articulated arms	F11	Fuse for socket outlet on the platform
S20	Lever switch for levelling of platform		

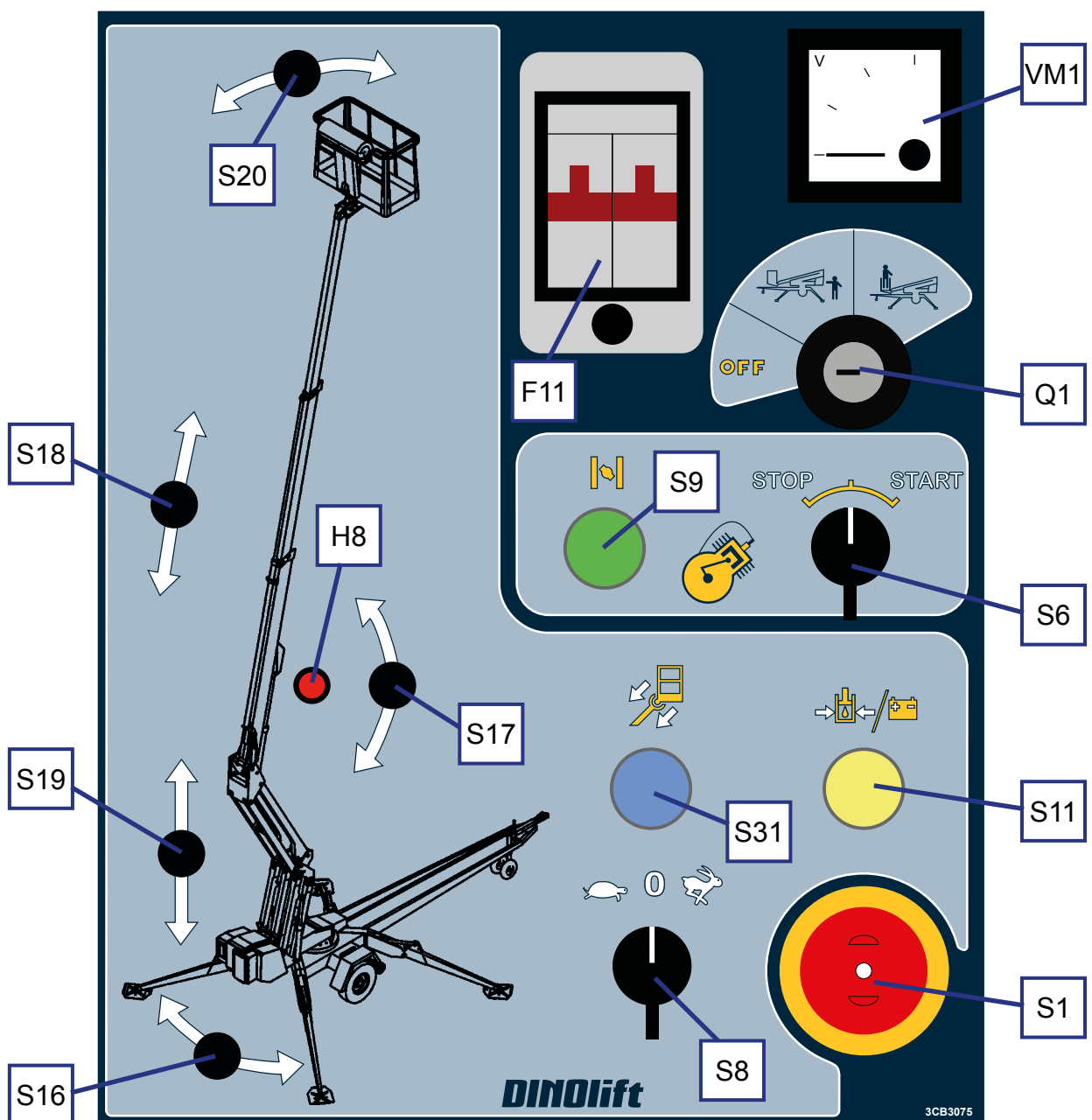

4.3.2. Operating the support outriggers from the chassis panel

S40	Startbutton for the battery-operated pump
S41	Lifting and lowering the support outrigger 1
S42	Lifting and lowering the support outrigger 2
S43	Lifting and lowering the support outrigger 3
S44	Lifting and lowering the support outrigger 4
S47	Activation switch
S48	Engagement/release of the pressing of the drive rollers

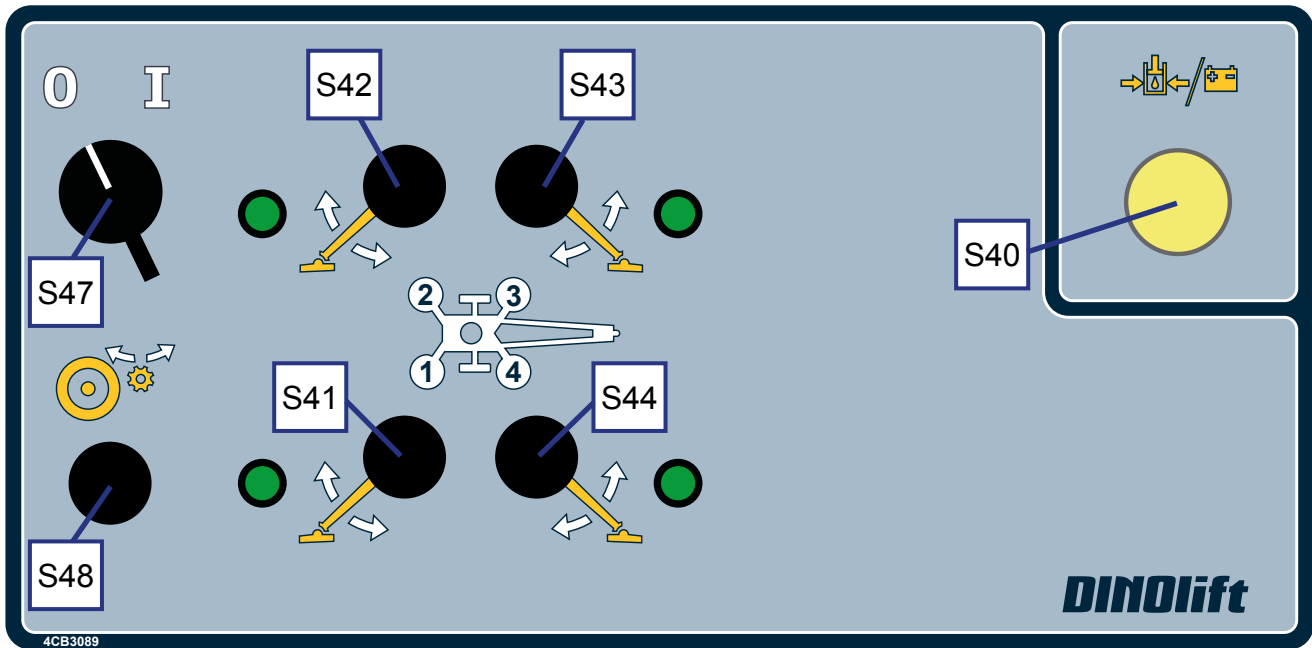

4.3.3. Operating controls in the platform control centre UCB

Close the cover of the chassis control centre before operating the controls on the platform. The cover must not be locked while the lift is in operation.

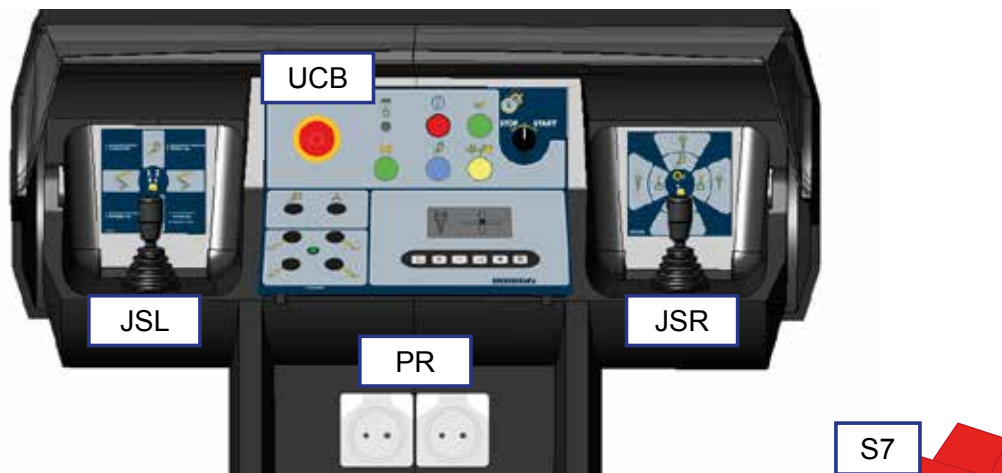

JSL	Joystick, left
JSR	Joystick, right
PR	Socket outlet 230 V
S7	Activation pedal

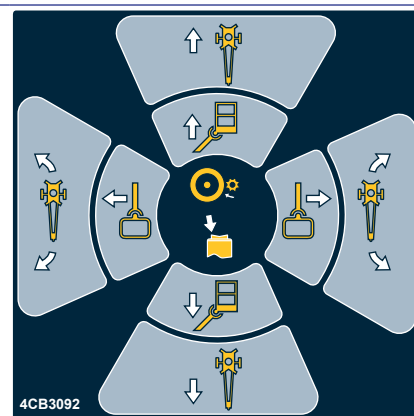
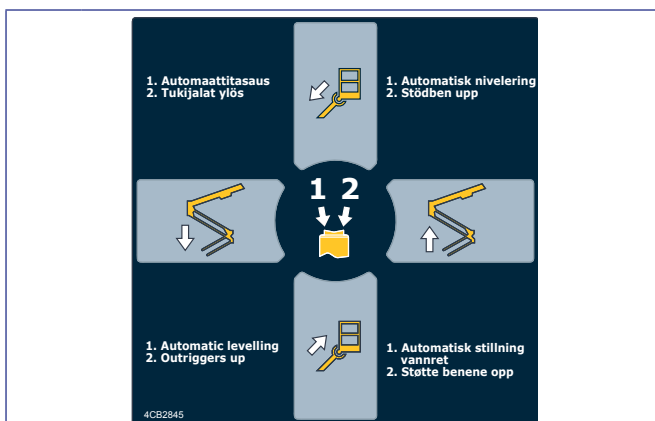

↑	Telescope in	Boom system	↑	Boom up
↓	Telescope out		↓	Boom down
←	Lowering the articulated arms	Drive	←	Turning the boom to the left
→	Raising the articulated arms		→	Turning the boom to the right
↙	Automatic levelling		↙	Engaging the pressing of the drive rollers
↘	Lifting the outriggers			

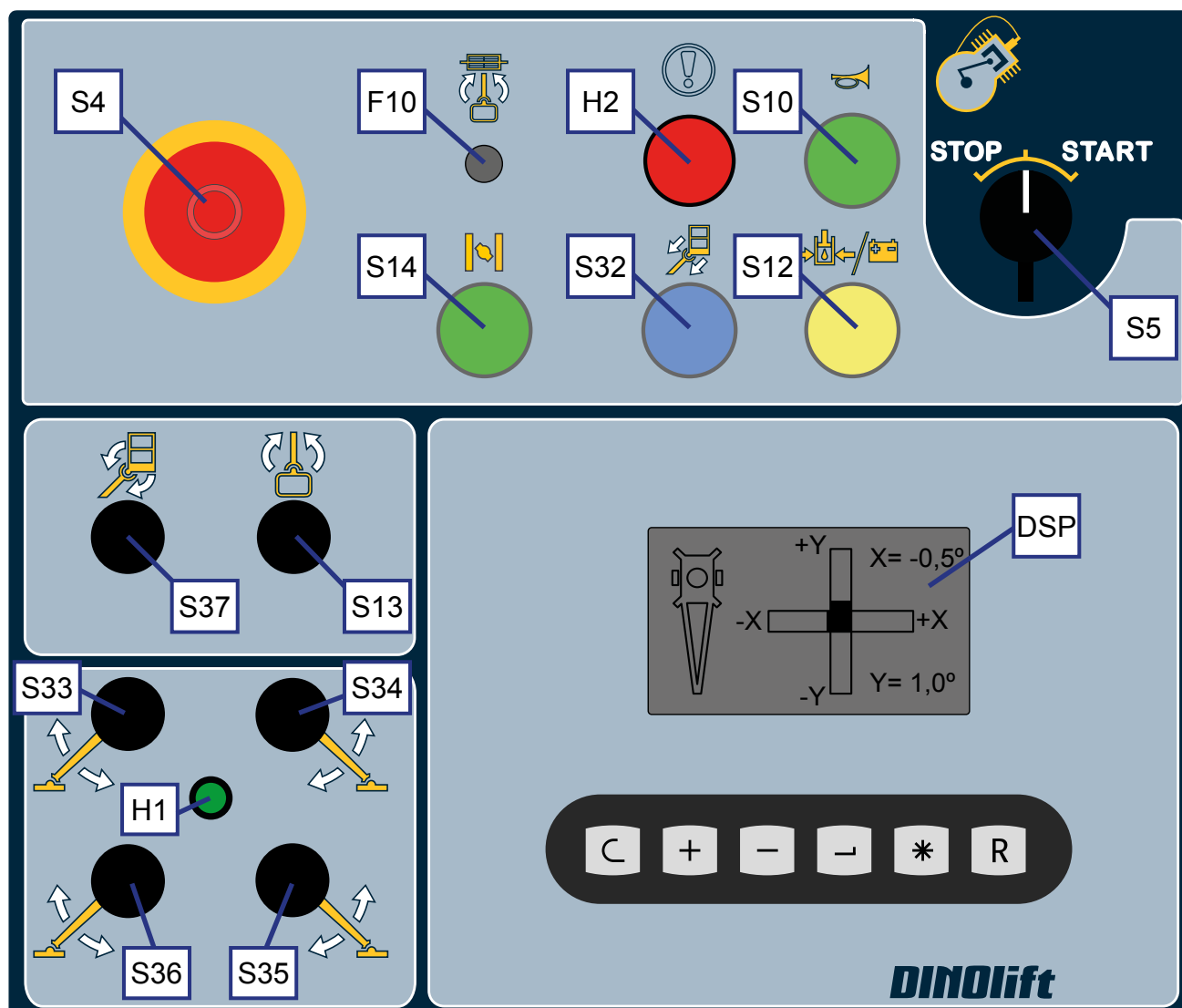

S5	Start and stop switches for the engine	S4	Emergency stop
S13	Turning the platform	S12	Start button for the emergency descent system
S14	Choke	S32	Pushbutton for retracting the telescope
S33	Lifting and lowering the support outrigger 1	S10	Sound signal
S34	Lifting and lowering the support outrigger 2	DSP	Display
S35	Lifting and lowering the support outrigger 3	H1	Signal light for the outrigger limit switches
S36	Lifting and lowering the support outrigger 4	H2	Alarm signal light
S37	Levelling the platform	F10	Automatic fuse for turning the platform

4.3.4. Automatic levelling and electric control of the driving device – DCB centre (option)

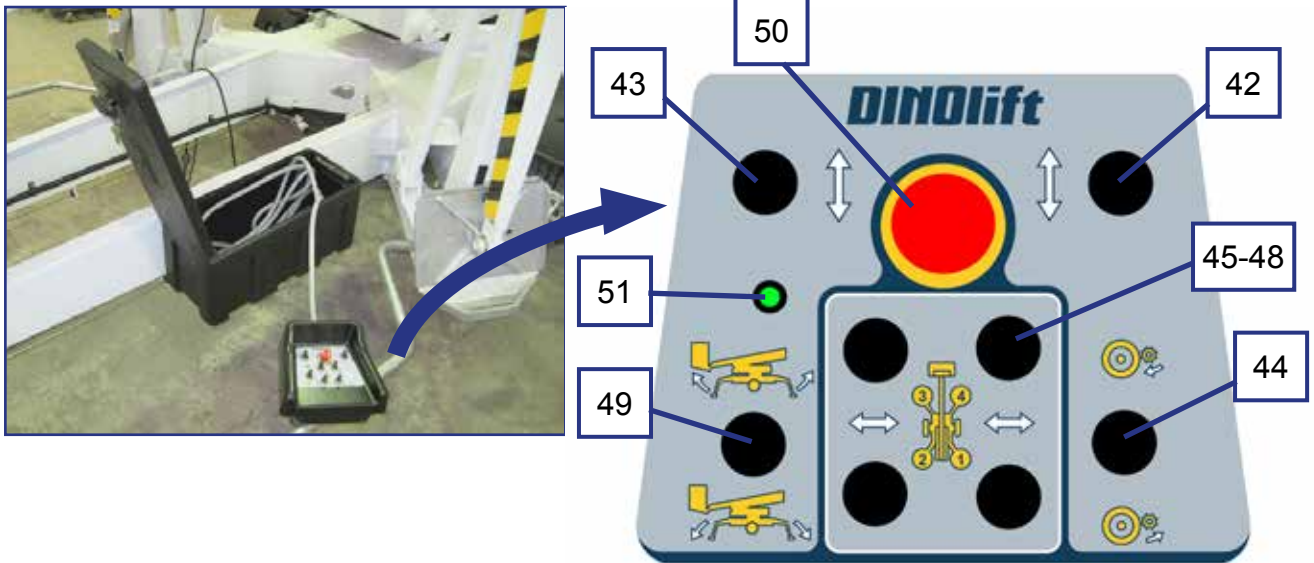

42	Lever switch for driving, right (to the front-rear)	49	Lever switch for automatic levelling
43	Lever switch for driving, left (to the front-rear)	50	Emergency stop
44	Depressing the driving device rollers (option)	51	Light for automatic levelling
45-48	Lever switches for outriggers 1-4		

5. OPERATING INSTRUCTIONS

5.1. START-UP

NOTICE

Before operating the lift, perform all daily maintenance measures listed in the maintenance schedule.

The operator must do a worksite inspection and daily maintenance:

- at the beginning of each workday
- before operating the lift at a new worksite
- when the operator changes in the middle of a workday

5.1.1. Worksite inspection

1. General information

- Is the lift suited for the intended job?
- Is the performance of the lift sufficient for the job? (reach, loadability etc.)
- Is the position of the lift safe?
- Is the lighting on the worksite sufficient?

2. Documents

- Are the Operation and Service Instructions for this lift present? (Manufacturer's instructions)
- Are inspections and servicing carried out in accordance with the instructions and have the defects affecting the safety been checked as repaired?
- (Inspection protocols)

3. Structure (Visual inspection and operational test)

- General condition of the lift
- Operation and protection of the controls
- Emergency stop, signal horn and limit switches
- Electrical appliances and wiring
- Oil leaks
- Load markings and signs

4. Operator

- Is the operator old enough?
- Has the operator received the required training?

5. Special issues on the worksite

- Are there any additional regulations relevant to the worksite or the work?

5.1.2. Positioning the lift

1. make sure that the ground is even and hard enough to support the lift in a steady, level position.

Soil material	Density	Max. ground pressure	
		P	kg/cm ² (N/cm ²)
Gravel	High density		6 (59)
	Medium density		4 (39)
	Loose		2 (20)
Sand	High density		5 (49)
	Medium density		3 (29)
	Loose		1,5 (15)
Fine sand	High density		4 (39)
	Medium density		2 (20)
	Loose		1 (10)
Sand / mud	High density (very hard to work)		1,00 (10)
	Medium density (hard to work)		0,50 (5)
	Loose (easily worked)		0,25 (3)

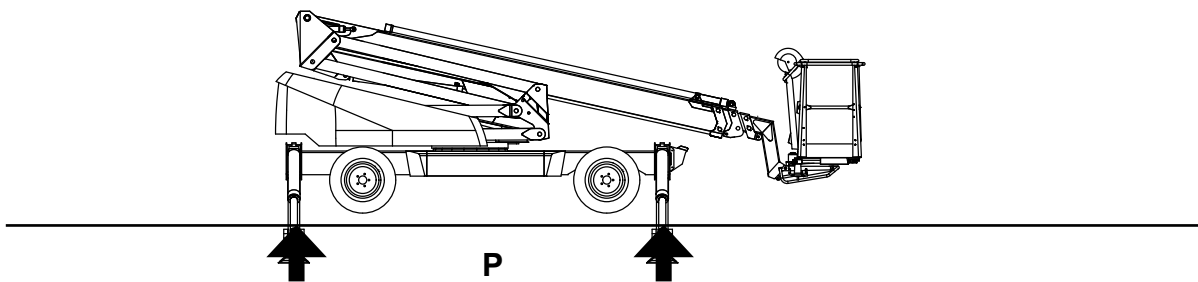

DANGER

If the ground is soft, use sufficiently large and sturdy additional plates under the support outriggers.

2. Drive the lift to the inspected lifting site
3. Engage the parking brake
4. Disconnect the lift from the towing vehicle

5.1.3. Starting the machine

1. Ensure that the main switch BMS is switched on. The switch is located above the lower control centre LCB.
2. Switch on the power via the switch Q1.

POWERED BY COMBUSTION ENGINE

3. Do not connect the mains cable.
4. Petrol-driven power pack: open the fuel cock and, as required, switch on the choke for the start
5. Start the engine via the lever switch.



If the battery is flat:

- Check that the key-switch Q1 is in the position UCB.
- Keep the button in front of the petrol-driven power pack depressed, and simultaneously, pull the starter string. Pull the starter string lightly until you feel resistance, then pull briskly.
- Keep the button depressed for about 1 minute in order to recharge the battery.
- Do not allow the starter grip to snap back against the engine.

Refer to the separate user manual for the diesel engine for instructions about starting up the engine, when the battery is flat.

Stopping the engine

1. The engine stops, when the lever switch is turned to the position STOP.
2. Petrol-driven power pack: after having stopped the combustion engine, close the fuel cock. The cock must be closed during towing of the unit!

NOTICE

The battery will be recharged only when the combustion engine is running. Allow the combustion engine to run also between the operations to maintain sufficient charge level of the battery.

NOTICE

Do not disconnect the main current while the diesel engine is running!

Disconnecting the power supply while the engine is running may damage the electronics of the diesel engine's charger.

ELECTRIC MOTOR

- For maximum out of the electric motor the voltage must 230 VAC (-10%/ +6%), and the frequency must be 50 Hz (the length of the connecting cable has some effect).
- 16A fuse.

Starting the electric motor

1. Connect the mains plug.
2. Switch on the power via the switch Q1.
3. The motor starts automatically
 - when the activation switch in the control centre for the outriggers is turned and the movement is activated
 - when the selector switch for the boom speed in the chassis control centre is turned and the movement is activated
 - when the pedal in the platform control centre is depressed and the movement is activated

Stopping the motor

The motor stops in 5 seconds after the movement has stopped

5.1.4. Supporting the lift

The support outriggers may only be operated, while the boom is resting on the support.

When operating the outriggers from the chassis control centre:

1. Turn the selector switch to the position "Chassis control centre LCB". 
2. Turn the activation switch S47 to the position 1 and keep it there as long as you operate the selected movement.
3. Turn the outrigger-specific lever switch to the desired direction of movement. All the outriggers can be operated simultaneously, if so desired.
4. Lower the front outriggers (on the tow-bar side).
5. Lower the outriggers in the rear. (do not damage the tow-bar jockey wheel)
6. Bring the lift to a level position using the outriggers as shown by the level gauge. The air bubble must be located inside the inner ring.
7. The green signal light next to the operating lever for the outrigger will light up as soon as sufficient force is exerted on the outrigger.



Note! Lighting up of the green signal lights does not necessarily prove that the lift is standing on a level!

When operating the outriggers from the platform control centre:

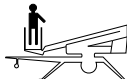
1. Turn the selector switch to the position "Platform control centre UCB". 
2. Press the pedal.
3. Turn the outrigger-specific lever switch to the desired direction of movement. All the outriggers can be operated simultaneously, if so desired.
4. Lower the front outriggers (on the tow-bar side).
5. Lower the outriggers in the rear. (do not damage the tow-bar jockey wheel)
6. Bring the lift to a level position using the outriggers with the help of the DSP inclination display. The columns in the display indicate the horizontal position, and the figures X and Y indicate the inclination in degrees. With the help of the display, check that the inclination in directions X and Y is less than 0,3°.
7. The green signal light H1 will illuminate as soon as all the outriggers have reached the support position and the limit switch circuit of the outriggers has closed.

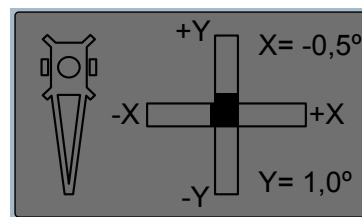

Note! Lighting up of the green signal light does not necessarily prove that the lift is standing on a level!

Levelling using the automatic levelling function (option)

1. Press the pedal.
2. Depress the left-hand side of the rocker switch on the left joystick in order to bring the lift to a level position.
3. Continue the levelling until the movement stops.
4. With the help of the display, check that the inclination in directions X and Y is less than 0,3°.

Always check that the lift is standing in a horizontal position. Readjust manually, if necessary.

Lifting the outriggers to the transport position using the automatic levelling

5. Press the pedal.
6. Depress the right-hand side of the rocker switch on the left joystick in order to lift the outriggers to the transport position.

NOTICE

If you have levelled the chassis of the lift ON A GRADIENT, turn the boom around carefully in the lower position to ensure that the turning device does not bang against the support outriggers or other obstacles.

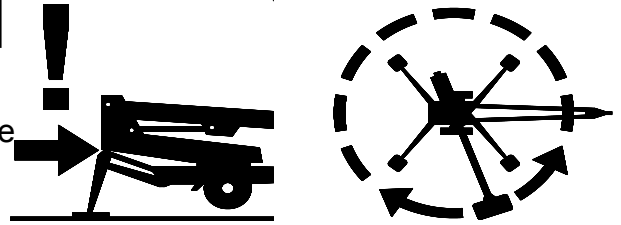

Before using the lift, always check that:

- the chassis is in the horizontal position, using the position indicator
- the wheels are off the ground
- the outriggers are firmly supported on the ground



DANGER

The operation is prohibited, if the lift is not properly supported and in a horizontal position.

Observe the effect of ice, possible rain and inclination of the surface on the support (the support outriggers must not slip on the surface).

5.2. OPERATION



WARNING

Carry out all the daily maintenance routines and inspections in accordance with the maintenance instructions before operating the lift. **Failure to check the safety devices may cause a serious injury or make the consequences of an accident worse.**

All the faults, observed in the safety devices, must be repaired before the use.

5.2.1. Operating the lift from the chassis control centre

1. Turn the selector switch to the position "Chassis control centre LCB".



2. Select the movement speed using the switch S8. The switch must be kept active throughout the operation. The switch has three positions:

0 none of the movements is operational



slow movements of the boom are operational



fast movements of the boom are operational

3. Select the desired movement and turn the lever switches S16–S20. Now the movement operates at the selected speed.
4. Lift the platform from the tow-bar and turn it to the side so that you can lower the boom.
5. Extend the telescope as much as is necessary to ensure that stepping onto the platform is safe.

NOTICE

Do not damage the tow-bar jockey wheel!

The movements of the boom are noticeably slower when the emergency descent system is used.

If the lift is operated from the chassis control centre, the speed of the boom movements cannot be adjusted continually using the control levers.





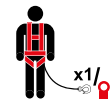

5.2.2. Operating the lift from the platform control centre

DANGER

Risk of falling! Wear a safety harness while on the platform, and fix it to the point marked for them. Make sure that the platform gate remains closed during the operation.

1. Turn the selector switch to the position "Platform control centre UCB", and remove the key. Do not lock the protective cover for the chassis control centre.
2. Step onto the platform and fix the safety harness to the fixing points on the platform.
3. Activate the operating controls by pressing the activation pedal.
Note! None of the movements must be activated while the pedal is being depressed. The pedal must be kept depressed throughout the operation.
4. **Activate the desired movement by means of the control lever.** Once the control lever is actuated, the engine revolutions increase or the electric motors starts. The boom movements operate as described in the table.



Lever	Movement	Movement speed	Symbol
JSR - up / down	Boom up / down	Stepless adjustment	
JSR - to the left / right	Turning the boom clockwise / counter-clockwise	Stepless adjustment	
JSL - to the left / right	Articulated arms up / down	Stepless adjustment	
JSL - up / down	Retracting/extending the telescope	Stepless adjustment	
S25 - to the left / right	Turning the platform clockwise / counter-clockwise	Constant speed	
S25 - up / down	Levelling the platform	Constant speed	

The movements can be operated simultaneously. If several movements are operated simultaneously, the speed of individual movements decreases.

Always try to keep the boom short during the lifting and lowering movements.

Observe when lifting the platform

- the operating range of the platform depends on the load (see "Technical Data") and

is monitored by the safety limit switches RK4 and RK5, which are located under the protecting cover

- The limit switches must not be adjusted or modified. The inspection and adjustment may only be carried out by an authorized serviceman.



DANGER

Risk of turning over the lift! Do not overload the lift.

Never add load onto the platform while the overload warning light is lit. The overload control system prevents any dangerous movements, if the platform load is too heavy with respect to the outreach.



It is strictly prohibited to take additional load in the upper position.

Do not exceed the lateral force (400N), or load the platform vertically more than allowed

Working a long time in the same position

- When the weather is warm, and the platform is kept for a longer period in the same position, it is not necessary to let the engine run continuously.
- when the weather is cold, it is, however, recommended to let the engine run to keep the hydraulic oil warm
- keep the battery sufficiently charged even during long-term work in the same position. As necessary, the state of charge of the battery must be ensured by power supply either from mains or from power pack.
- check the stability and condition of the base regularly during the operation, taking into account the weather and ground conditions

When moving the platform, remember the following

- beware of high voltage power lines
- do not touch open electric wires
- do not throw objects from the platform
- do not damage the lift
- do not damage other devices



CAUTION

The lift itself, the buildings around it and other obstructions constitute a risk of getting squeezed. Hands and legs must be kept inside the work platform while the platform is moving. Also beware of any obstacles above the platform.

Lowering the platform to transport position:

Always retract the telescope completely and turn the platform perpendicular to the boom before lowering the boom onto the transport support.

NOTICE

Do not damage the tow-bar jockey wheel while lowering the platform to the transport position!

When leaving the lift

- drive the lift to a safe position, preferably to the transport position
- switch off the power unit
- prevent unauthorized use of the lift by locking the control centre cover

5.2.3. Special instructions for winter use

The lowest allowed operating temperature of the lift is -20 °C

In cold conditions, carry out the following special actions in addition to the normal start-up procedure

1. Let the power pack run for a few minutes before starting the movements.
2. To ensure the proper operation of the valves, do first a few warm-up movements to change warm oil in the cylinders.
3. Check that the limit switches and the emergency descent devices are operational and clean (from dirt, snow, ice, etc.).
4. Protect the control centre and the platform from snow and ice whenever they are not in use.
5. Ensure that the batteries are charged. Flat batteries freeze easily.



Always keep the lift free from dirt, snow etc.

5.2.4. Ending the work

At the end of the workday:

1. Retract the telescopic boom fully.
2. Check that the platform is perpendicular to the boom.
3. Lower the boom/platform onto the support on the tow-bar. The limit switch on the transport support prevents the operation of the support outriggers if the platform is not down.
4. Close the control centre cover on the work platform.
5. Turn the selector switch to position OFF, and turn off the main switch.
6. If you want to recharge the battery, leave the mains cable connected; otherwise disconnect the lift from the mains supply.
7. Make sure that the covers are locked.

NOTICE

To ensure proper operation and long service life of the batteries, it is recommended to always recharge them at the end of each workday, even though there was still plenty of charge left. Storing the batteries flat shortens their service life, and flat batteries also freeze easily.

5.3. TRANSFERRING THE LIFT

The lift can be transferred by towing or using its own driving device.



The lift may only be moved in the transport position. No persons or load are allowed on the platform during the transportation.

5.3.1. Preparing the lift for transport

During transfer, the lift must always be in the transport position.

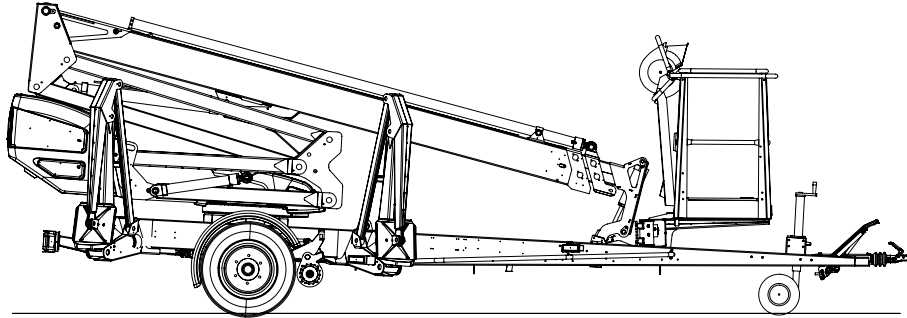

Prepare the lift for the transfer as follows:

1. Retract the telescopic boom fully.
2. Check that the platform is perpendicular to the boom.
3. Lower the boom/platform onto the support on the tow-bar. The limit switch on the transport support prevents the operation of the support outriggers if the platform is not down.
4. Close the control centre cover on the work platform.
5. Turn the selector switch (1) to position "chassis control centre".
6. Lift the support outriggers.
Lift at first the rear support outriggers 3-4 (do not damage the rear lights), then the front support outriggers 1-2 (do not damage the jockey wheel)
7. Make sure that the covers are locked.

If you intend to tow the lift:

8. Apply the parking brake.
9. Make sure that the driving device is disconnected.
10. Turn the selector switch to position OFF and disconnect the lift from the power supply.

5.3.2. Using the driving device

The hydraulic driving device is intended for moving the lift within the work area if the towing vehicle cannot be used.



If the terrain is rough, use the remote control panel or a towing vehicle. When using the remote control panel, always try to position yourself higher than the machine in the terrain.

1. Make sure that the platform is in the transport position and the outriggers have been lifted to the upper position.
2. Make sure that the mains cable is long enough to cover the whole travel distance – or that the cable has been disconnected.
3. Fix the additional jockey wheel in place. The wheel is located on the left-hand side behind the machine.



Driving from the platform

1. activate the pedal
2. press the driving device against the tyre depressing the left face of the rocker switch on the right-hand joystick (JSR)
3. Release the parking brake
4. Activate the pedal, and perform the driving operation using the right-hand joystick.
5. Do not drive the jockey wheel into obstacles or potholes.

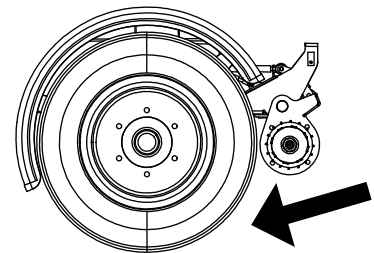

Driving by means of the remote control

1. Press the driving device against the tyre by turning the lever switch S47 in the chassis control panel to the position 1 and selecting the direction of rotation for the rollers using the switch S48.
2. Release the parking brake
3. Drive the unit using the arrow keys on the remote control. The remote control is located on top of the chassis control panel at the rear of the machine.

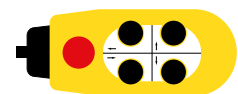
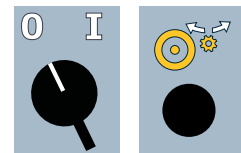

After the driving

1. Apply the parking brake
2. Disconnect the driving device from the tyre using the switch S48 in the chassis control panel.

On a slope:

1. When driving on a slope, the tow-bar must always point towards the descent. Never drive with the driving device with the tow-bar pointing towards the ascent.
2. Always place chocks under the wheels before disconnecting the device from the towing vehicle.
3. Always apply the handbrake before disconnecting the lift from the towing vehicle.
4. Only use the handbrake as a parking brake or for emergency stopping.
5. When transferring the lift using the driving device:
 - take care not to allow the wheel to roll over your foot
 - look out for sudden sideways movements of the tow-bar
 - be careful not to cause danger to other people and the environment
6. Do not move the device on a slope using only hand-power. You may lose control over it and cause an injury.
7. Never park a vehicle combination on a slope.
Never leave the lift on a slope being supported only by the self-braking action of the driving device.

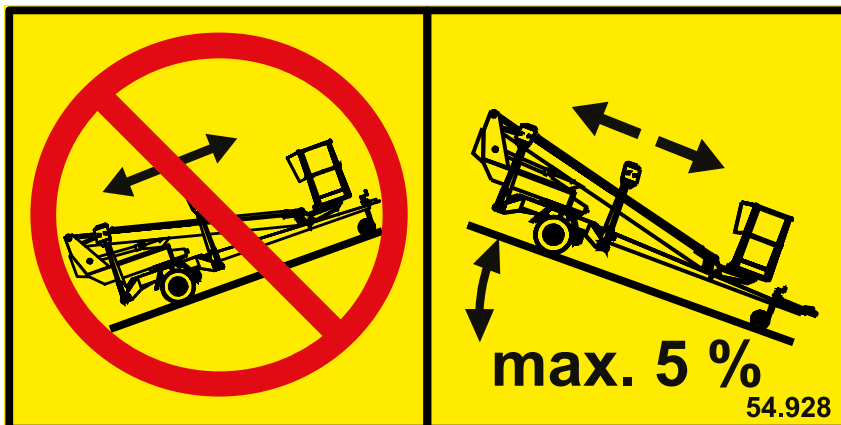

Do not drive downhill with the driving device, if the inclination of the surface is more than 5 per cent, (corresponding to a descent of 0.5 m over a distance of 10 m). If the gradient of the surface is greater than this, you may lose control of the device.

5.3.3. Towing the lift

Connecting to the towing vehicle

1. Lift up and push forward (in the driving direction) the handle of the ball-coupling. Now the ball-coupling is released.
2. Press the ball-coupling onto the towball using only a little force. The connection and locking take place automatically.



Always make sure, after the connection, that the ball-coupling is properly locked.

3. Connect the emergency stop wires and light plug to the vehicle. Check the cable for chafing and proper operation of the wires.
4. Check the operation of the lights.
5. Carefully release the parking brake and make sure that its locking is in order and that its handle stays in the lower position.
6. Lift up the jockey wheel to the transport position.



Clean and lubricate the ball-coupling regularly.

In particular, if you are parking or disconnecting the lift from the towing vehicle on a slope, apply the parking brake as firmly as possible. After having applied the parking brake, push the lift backward to make the reverse automatics release the brake shoes. The spring cylinder pulls the parking brake tighter, and the brakes of the vehicle will again be properly engaged.

Adjust the brakes according to the service instructions.

Place chocks under the wheels as an additional precaution.

NOTICE

Observe the national traffic regulations, the local and worksite-specific instructions, as well as the instructions concerning the towing vehicle.

Always ensure before towing:

- transport position of the outriggers
- locking of the ball-coupling
- operation of the lights, connection of the cable
- that the parking brake is disengaged
- condition and pressure of the tyres. The correct pressure ratings are marked both on the tyres and on the jockey wheel bracket.
- attachment of the safety wire
- locking of the brakes after the transportation
- locking of the jockey wheel in its upper position
- that the driving device is disconnected from the wheel
- that there is no load on the platform



Always use chocks under the wheels when disconnecting the lift from the car.

5.3.4. Lifting the device

The device can be lifted using the lugs shown in the picture. The lifting lugs are located symmetrically on both sides of the lift.

During lifting the aerial work platform must be in the transport position. Remove all loose material from the top of the frame structures and the work platform before lifting.

Use for lifting a suitable crane with sufficient capacity and relevant accessories. Check the weight of the lift in the technical specifications.



Be careful not to damage the unit during the lifting operation.

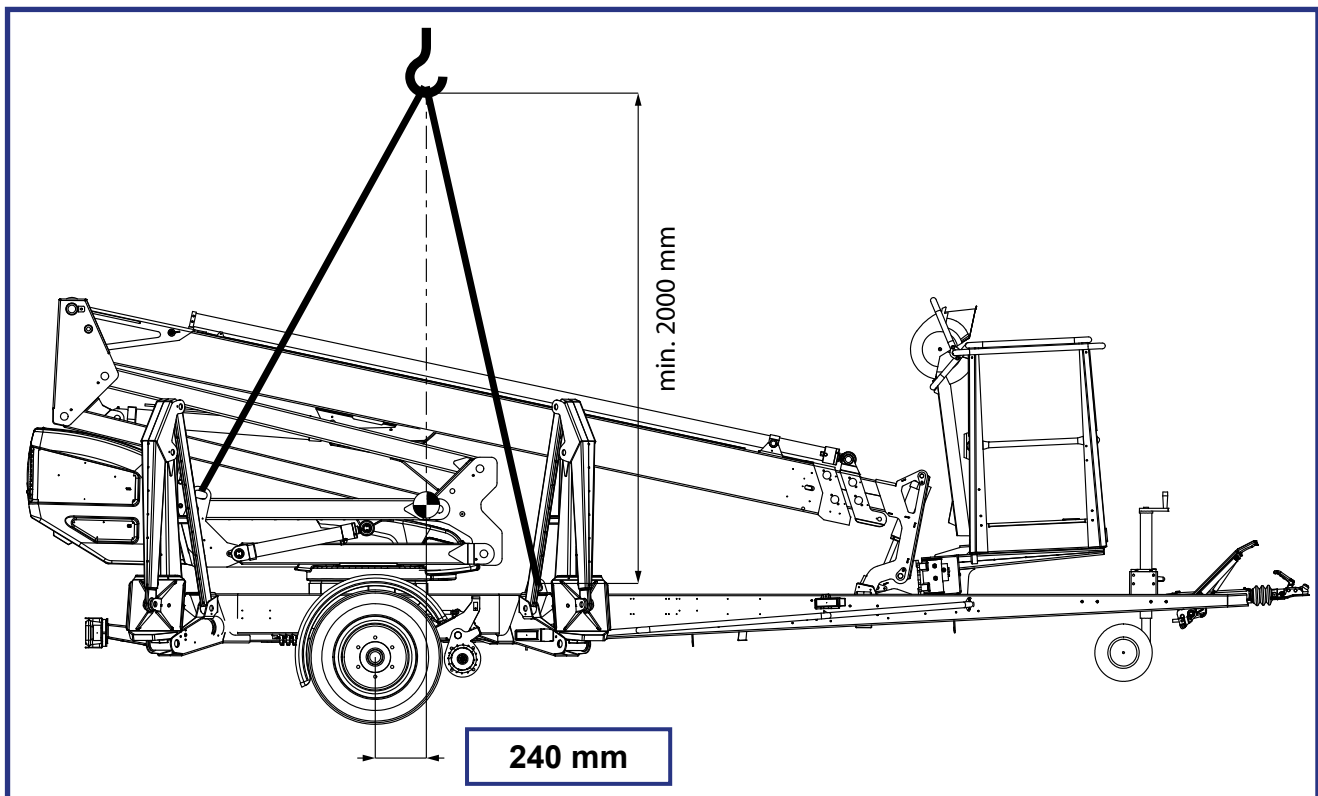

5.4. LONG-TERM STORAGE

Clean the machine carefully, lubricate it and apply protective grease to it before putting it into storage for a longer period of time (see point "Lubrication plan"). Repeat the cleaning and lubrication procedures when you resume the operation.

NOTICE

If you leave the lift standing for a longer period of time, for example over the winter, we recommend propping it up to release any load from the wheels.

The periodic inspections must be executed following the steps described in the instructions.

5.3. IN CASE OF EMERGENCY

5.3.1. When at risk of losing the stability

Reduced stability can be caused by a fault in the lift, the wind or other lateral force, collapse of the standing base or negligence in providing sufficient support. In most cases one sign of reduced stability is the inclination of the lift.



1. If there is time, try to find out the reason for the reduced stability and the direction of its effect. Warn other people on the worksite using the alarm signal.



2. If possible, reduce the load from the platform in a safe manner.



3. Reduce the outreach to the side by retracting the telescope. Avoid abrupt movements.

4. Turn the boom away from the danger zone, i.e. to a position where the stability of the lift is normal.

5. Lower the boom.

If the stability has been lost as a result of a fault in the lift, repair such a fault immediately.



Do not use the lift until the fault has been repaired and the condition of the lift has been verified.

5.3.2. In case of overloading



1. If there is time, try to find out the reason for the reduced stability and the direction of its effect. Warn other people on the worksite using the alarm signal.

2. If possible, reduce the load from the platform in a safe manner.



3. Use the “telescope in” pushbutton, if the set value of the RK5 has been exceeded.

4. The green light will illuminate as soon as the overloading situation is reset. After this, the machine may be operated normally.

5.3.3. In case the power supply is interrupted

As a precaution against power failure or other malfunction of energy supply, the lift is equipped with a battery operated emergency descent system.



1. Start the emergency descent system via the pushbutton. The emergency descent system is operational only when the pushbutton is being depressed.

When the emergency descent system is operated from the platform control centre, the telescope automatically moves inward.

As soon as the telescope reaches its inner position, the limit switch RK8 switches the function to the descent movement of the boom and the articulated arms.

Lower the boom system sufficiently in order to enable safe exit from the platform.

2. As necessary, drive the boom onto the transport support and lift the outriggers from the chassis control centre by means of the emergency descent system.

Start the emergency descent system from the chassis control centre depressing the emergency descent button, and select the desired movement using the lever switch for this movement.



1. Reduce the outreach to the side by retracting the telescope. Avoid abrupt movements.
2. Lower the boom and the articulated arms by means of the emergency descent system. Finish the operation by turning the boom.
3. Establish the reason why the energy supply was interrupted.

Operating the outriggers and the drive rollers by means of the emergency descent system

1. Ensure that the boom is resting on the transport support.
2. Operate the emergency descent system from the control centre for the outriggers.

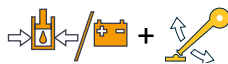

3. Lift the outriggers using the lever switches. Lift the outriggers one by one in order to lower the unit smoothly.

Note! If the unit is not connected to the towing vehicle, apply the parking brake before disengaging the drive rollers!



4. Disengage the drive rollers from the tyres. The rollers move at a slightly different pace, so keep the movement activated sufficiently long. Before towing the unit, ensure that the drive rollers on both sides are at a sufficient distance from the tyre.

Always check the condition of the battery for the emergency descent system before putting the lift into operation.

(See point “Operation of the safety devices”)

Setup of the emergency descent system

- 12 V, 44 Ah
- recharger
- hydraulic unit 12 VDC

The hydraulic unit comprises

- pressure relief valve, set value 16 MPa (160 bar)
- check valve
- direct current motor of 800 W

Note! Starting of the emergency descent system stops the 230 VAC motor.

5.3.4. In case of malfunction, when even the emergency descent system is not operational

If not even the emergency system is working, try to warn other personnel present on the site or call for more help. When help arrives, try to

- restore the power supply required for normal operation of the lift
- make the emergency descent system operational by, for example, changing the battery
- resume the lift's normal operation by other means

Always check the condition of the emergency descent system battery before putting the lift into operation (see point "Operating from the chassis control centre").

6. INSTRUCTIONS FOR FAULT-FINDING

FAULT	REMEDY
-------	--------

1. No voltage supply to the control centre

Main switch turned off.	Turn the main switch on.
Timer card cannot be activated.	Check that the key-switch is in position 1.

2. The electric motor does not start

Key-switch is in the wrong position.	Turn the key-switch to the desired operating location.
Emergency stop button has jammed in the lower position.	Pull up the button and re-start the engine by actuating any of the control movements.
No mains supply (230 VAC) to the voltmeter.	Check the fault current switch and the extension cords.

3. Power unit does not start

Battery is flat.	Recharge the battery.
The mains cable is plugged.	Disconnect the plug from the mains.

4. Power unit cranks but does not start

Fuel tank is empty.	Fill the fuel tank.
Choke is off.	Press the choke button (cold engine). 
Throttle lever is in the idling position.	Increase the engine revolutions.

5. Platform cannot be turned

Automatic fuse F10 has tripped.	Reset the automatic fuse via its reset button.
---------------------------------	------------------------------------------------

6. None of the boom movements is operational, although the electric motor is running and the selector switch stands in the correct position (operation either from the chassis control centre or the platform control centre)

Green signal light for the outriggers is not illuminated. Limit switches for the outriggers have not closed.	Make sure that all the outriggers are steady supported on the ground.
The lift has been overloaded.	Reduce the platform load
	or Retract the telescope until the platform returns inside its operating range (the green light in the platform control centre lights up). 

FAULT	REMEDY
-------	--------

7. Outriggers do not move

The boom is not resting on the transport support.	Drive the boom onto the transport support.
The selector switch is in the wrong position.	Turn the selector switch to the correct position.
The limit switch on the boom support has not closed.	Drive the boom onto the transport support.

8. Malfunctions of platform movements – only one of the movements can be operated

Lifting and lowering of the boom and the extension of the telescope are not operational, the red light is illuminated on the platform and in the chassis control centre, and the buzzer is audible.	The boom has been overloaded; retract the telescope and retry the operation (automatic reset).
-----------------------------------------------------------------------------------------------------------------------------------------------------------------------------------------------------	------------------------------------------------------------------------------------------------

18. Driving device is not operational, although the selector switch is in the correct position

Boom is not resting on the transport support.	Drive the boom onto the support.
-----------------------------------------------	----------------------------------

24. Wheel brakes overheat

Parking brake not completely released.	Release the parking brake completely.
----------------------------------------	---------------------------------------

25. Ball-coupling is not locked

Inner parts of the ball-coupling dirty.	Clean and lubricate the inner parts of the ball-coupling.
Tow-ball of the towing vehicle too large.	Make sure that the towing ball of the towing vehicle is the right size for the lift's tow hitch. According to DIN74058, the diameter of the ball must be max. 50 mm and min. 49.5 mm.

In all other fault conditions, the lift must be submitted to a qualified DINO service provider.

To avoid malfunctions

- Follow the operating instructions
- Beware of dangerous situations, which can damage the lift
- Keep the lift clean and protect it against moisture

NOTES

NOTES

7. MAINTENANCE SCHEDULE

Service	Service interval	Service person	Instructed
A	Daily	Operator	operating instructions
B	every month/100 hours*	Competent person who is familiar with the lift	maintenance instructions
C	every 6 months/400 hours*	Competent person who is familiar with the lift	maintenance instructions
D	every 12 months/800 hours*	Technical specialist, who is well familiar with the structure and operation of the lift	maintenance instructions
E	When necessary	Technical specialist, who is well familiar with the structure and operation of the lift	maintenance instructions

* Service interval in months or operating hours, depending on whichever comes first.

NOTICE

In addition to the daily maintenance routines according to the maintenance schedule, every operator is obliged to perform a site-specific worksite inspection.

T = Check (general/visual checking of condition).

P = Thorough Inspection. To be performed following the separate procedure described in the maintenance instructions.

V = Grease

S = Carry out replacements, repairs or other maintenance tasks described in the instructions

Maintenance measures		A	B	C	D	E
1	Frame structures, boom system and platform	T	T	T	P	
2	Bearings of the overload protection device		V	T/V	T/V	
3	Joints of the outriggers and the outrigger cylinders		V	T/V	P/V	
4	Joints of the outriggers' foot plates and the moving parts of the outrigger limits		V	T/V	P/V	
5	Bearings of the boom and the articulated arms		V	T/V	T/V	
6	Bearings of the levelling system of the platform		V	T/V	T/V	
7	Articulation bearings of the levelling cylinders		V	T/V	T/V	
8	Articulation bearings of the lifting cylinders		V	T/V	T/V	
9	Sliding surfaces and rollers of the telescope		T/V	T/V	T/V	
10	Bearing of telescope cylinder			T/V	T/V	
11	Condition of cylinders				P	
12	Flyer-chain			V	P/V	
13	Checking and adjusting the play between slide pads and surfaces		T	T	T	
14	Turning device			V	P/V	
15	Electro-hydraulic rotary adaptor				T	
16	Tyres and tyre pressures	T	T	P	P	
17	Tow hitch/overrun		T	V	P/V	
18	Jockey wheel slide and threads				P/V	

Maintenance measures		A	B	C	D	E
19	Condition of brakes			T	T	
20	Axle and suspension				P	
21	Driving device		T	V	P	
22	Lights	T	T	T	P	
23	Hydraulic oils	T	T	T	S	
24	Hydraulic hoses, pipe and connections	T	T	T	P	
25	Condition and attachment of battery and wiring		T	T	P	
26	Hydraulic pressure				P	
27	Condition and attachment of safety devices				T	
28	Operation of safety devices (limit switches)	T	T	T	P	
29	Operation of overload limit switches			T	P	S
30	Operation of load regulation valves			T	T	
31	Operation and condition of platform's levelling system		T	T	T	
32	Operation and condition of controls on platform	T			P	
33	Operation of emergency descent, emergency stop and sound signal	T	T	T	T	
34	Stickers, plates and instructions	T	T	T	T	
35	Test loading				P	
36	Anti-corrosion treatment				T	S
37	Adjusting the movement speeds					S
38	Special inspection					S

Always lubricate the lift and apply a protective grease film immediately after the washing.

The lift must always be subjected to a special inspection after an exceptional event. Special inspection is required if the lift has been damaged in a manner, which may affect its load-bearing capacity or safe operation. Consult the maintenance manual for more detailed instructions.

NOTICE

If the lift is equipped with a petrol-driven or a diesel power pack, then in addition to the normal maintenance routines must also be carried out the service measures in accordance with the power pack's manual.

NOTICE

Under demanding conditions where moist, corrosive substances or corrosive climate may speed up the deterioration of the structures and induce malfunctions, the maintenance intervals must be shortened, or the influence of corrosion and malfunctions must be reduced by using appropriate protective means.

7.1. SCHEDULE FOR INSPECTIONS REQUIRED BY THE AUTHORITIES

The inspections must be performed in accordance with local and national regulations, in accordance with the legislation and standards.

The lift must be subjected to a **start-up inspection** before it is used for the first time and before starting it up the first time after a major repair or modification work.

The lift must be subjected to a thorough **periodic inspection** with related **test drive** at intervals of year.

The inspection must be carried out within twelve (12) months of the first inspection or previous regular inspection.

In connection with the periodic inspection the lift must be subjected to a **non-destructive inspection/inspection disassembled** in general at intervals of ten (10) years from the start-up date.

In addition, the lift must **be inspected** to the extent applicable after any exceptional situation

The inspections of the lift must be carried out at regular intervals as long as it is in use. If the lift is used under extreme conditions, intervals between the inspections shall be reduced.

The overall operating condition of the lift as well as the condition of the safety-related control devices shall be established in the regular inspections. Particular attention shall be paid to changes, which affect the operational safety.

In connection with the regular inspection shall be established to what extent the lessons and practical experience gained since the previous inspection could be utilized to improve the safety even more.

For the inspection must be assigned an **expert inspection body with documented evidence of competence** or an **expert with documented evidence of competence**.

A **protocol** must be drawn up of the executed inspections. The protocols of the start-up and periodic inspections must be kept with the lift or its immediate proximity for at least five years.

NOTICE

Check the regulations for the inspections and the competence of the inspector with the local authorities.

7.2. LUBRICATION PLAN

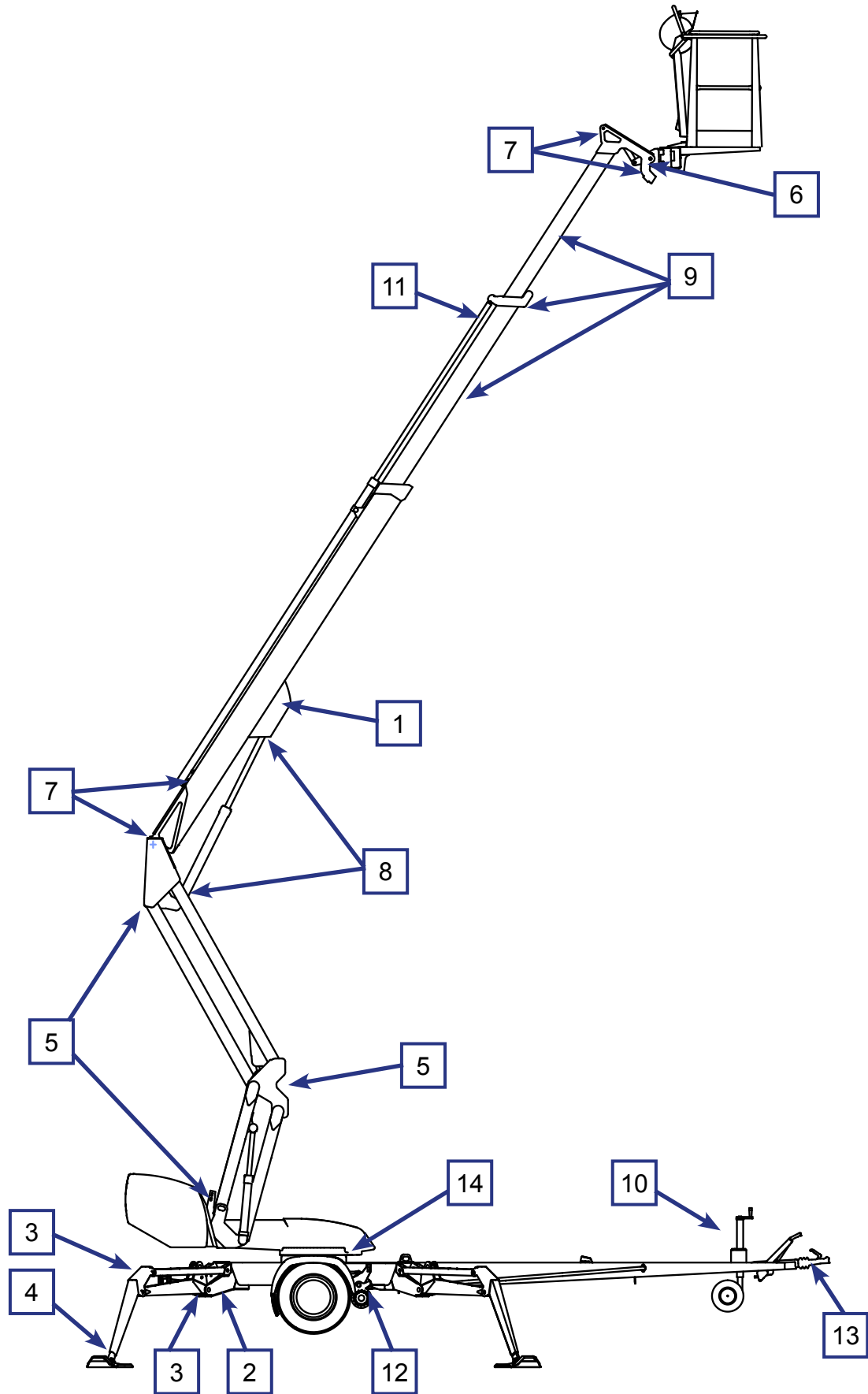

8. ROUTINE MAINTENANCE DURING OPERATION

The maintenance operations, that are the responsibility of the operator, are described in this chapter.

The more demanding maintenance operations that require special skills, special tools or specific measurements and adjustment values are instructed in the separate Maintenance Instructions. In such maintenance and repair cases, the operator shall contact an authorized service provider, the distributor or the manufacturer.

Make sure that all the service and maintenance procedures of the lift are performed in time and according to the given instructions.



WARNING

Any such faults, observed during operation or periodic service, which affect the operational safety of the unit, must be repaired before the lift is used next time.

Keep the lift clean. Clean the lift especially carefully before services and inspections. Impurities may cause serious problems, for example, in the hydraulic system.

Use original spare parts and consumables. Consult the spare parts list for more detailed information about the parts.

The first service after 20 hours of operation

- change the pressure and return filter elements
- adjust the brakes according to the instructions (see point “Wheel brakes and bearings”)
- check the wheel bolts for tightness after about 100 km of driving

If the lift is operated under demanding conditions (in exceptionally humid or dusty environment, corrosive climate, etc.) the intervals between the oil changes and the other inspections shall be shortened to meet the prevailing conditions in order to maintain the operational safety and reliability of the lift.

The timely performance of the periodic servicing and the inspections is absolutely mandatory, because neglecting them may impair the operational safety of the lift.

The guarantee will not remain valid, if the servicing and the periodic inspections are not performed.

8.1. INSTRUCTIONS FOR DAILY MAINTENANCE AND INSPECTIONS

8.1.1. Check the condition of chassis, the boom and the work platform

Check visually the condition of the access routes, the work platform, the platform gate and the handrails.

Check visually the condition of the boom and the frame structures.

8.1.2. Check the tyres and tyre pressure

Check visually that the tyres are duly inflated, and do not show any damage.

8.1.3. Check the lights

Check the condition of all the warning and signal lights as well as the road traffic lights of the trailer.

8.1.4. Check the hydraulic oil level

Check the hydraulic oil level with the platform in the transport position.

if necessary, top up hydraulic oil to the level with the upper edge of the level eye.

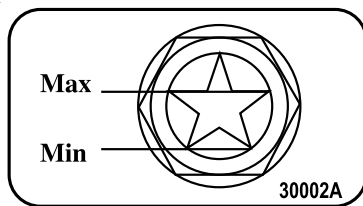

The hydraulic oil tank is located under a cover on the right-hand side of the lift.

At the same time, check in the level eye of the oil tank that the oil is looking clean and normal (no excess foam etc.).

8.1.5. Check the hydraulic hoses, pipes and connectors

Check visually the hydraulic hoses, pipes and connections.

Make sure that there are no visible oil leaks.

Replace any externally damaged hoses and clashed pipes or fittings.

8.1.6. Check the operation of the safety limit switches

Test the operation of the safety limit switches that prevent the movements of the boom and the outriggers as follows:

1. The lift is in the transport position with the outriggers in the upper position, and the driving device connected.
2. Lift the boom via the controls in the chassis control centre.
The boom must not operate in any position of the selector switch.
3. Lower the outriggers to the operating position of the lift
4. Using the controls in the chassis control centre, lift the boom so much that it raises from the support
5. Drive the outriggers.

The outriggers must not operate in any position of the selector switch.

8.1.7. Check the operating controls

Check the operating controls of the platform control centre and the chassis control centre:

- check the overall condition of the operating controls
- test all the movements. Ensure that all the movements stop when the control lever is released.

8.1.8. Check the operation of the emergency descent, the emergency stop and the sound signal

Test the operation of the emergency stop, the emergency descent system and the sound signal from both the chassis control centre and the platform control centre.

- lift the boom about 1-2 metres (using lever 8) and extend the telescope 1-2 metres (using lever 9) keeping the emergency stop button depressed – the movement shall now stop
- using the emergency descent, retract first completely the telescope, then lower the boom
- pull up the emergency stop button
- test the operation of the sound signal

8.1.9. Decals, stickers and signs

Check that all the signs, warning decals and pictorials on the control centres are in place, intact and clean.

8.1.10. Instruction manuals

Check that the user manuals accompanying the lift are legible.



BLANK

9. CHANGE OF OWNER

For the owner of the lift:

If you have purchased a used DINO lift from some other than the manufacturer, please post your details to the manufacturer using the form on this page, and send it to:

info@dinolift.com

This information makes it possible for us to provide you with the safety bulletins and other campaigns relevant to your machine.

Note! It is not necessary to inform about a rented machine.

Machine model: DINO _____

Serial number: _____

Previous owner: _____

Country: _____

Date of purchase: _____

Current owner: _____

Address: _____

Country: _____

Contact person

Name and position in the company: _____

Telephone: _____

E-mail: _____

NOTES

NOTES