

Instruction manual Electric chain hoists and travel trolleys

EURO-MODEL 2000

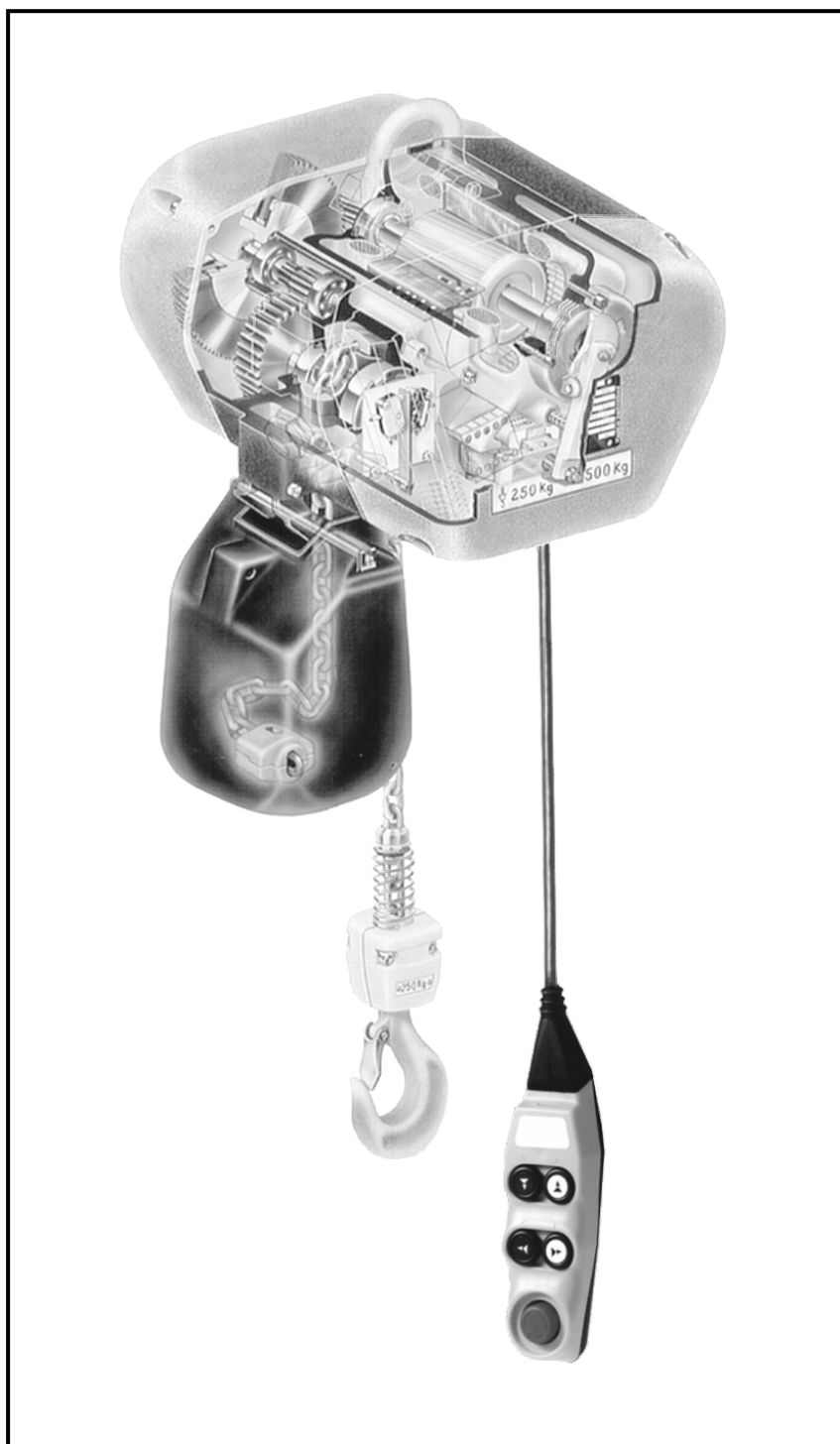
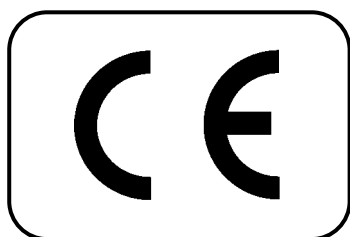

EM
EME
EHF
EMFE
EMS
EMK
EMR
EMH

TABLE OF CONTENTS

	Page		Page
0	General directions	3	
0.1	General safety directions	3	
0.1.1	Safety and hazard precautions	3	
0.2	General safety specifications and procedures	3	
0.2.1	Warning colour/Marking/Danger signs	3	
0.3	Special safety directions	3	
0.4	Notes on hazard protection	4	
0.4.1	Hazards caused by mechanical influences	4	
0.4.2	Hazards caused by electrical energy/power supply ...	4	
0.4.3	Sound level (SPL)	4	
0.5	Technical status	4	
0.5.1	Technical datas	4	
0.5.2	Recurrent checks	4	
0.6	Operational parameters	4	
0.6.1	Directions for the use of the instruction manual	5	
1	Description.....	5	
1.1	Operating conditions	5	
1.2	General functional description.....	5	
1.2.1	Control/Limit switches	5	
1.2.2	Control elements	5	
1.2.3	Motor	5	
1.2.4	Brake	5	
1.2.5	Slip clutch.....	5	
1.2.6	Gears	5	
1.2.7	Chain drive	6	
1.2.8	Travel trolleys.....	6	
2	Start-up.....	6	
2.1	Transport and assembly.....	6	
2.2	Connection	6	
2.2.1	Power connection for operating voltage.....	6	
2.2.2	Earth connections	6	
2.2.3	Direction of rotation check	6	
2.2.4	Load chain	6	
2.2.5	Chain bucket.....	6	
2.2.6	Single fall operation	7	
2.2.7	Double fall operation.....	7	
2.2.8	Limit switch	7	
2.3	Push travel trolley	7	
2.4	Electric travel trolley.....	7	
2.5	Further checks following assembly and installation...	7	
2.5.1	Check the fuses	7	
2.5.2	Electrical connection check	7	
3	Service and maintenance.....	7	
3.1	General regulations for service- and maintenance work.....	7	
3.2	Maintenance	8	
3.2.1	Maintenance summary.....	8	
3.3	Service.....	8	
3.3.1	Service summary	8	
3.3.2	Brake system	8	
3.3.3	Load chain	8	
3.3.4	Limit switch	8	
3.3.5	Gears	8	
3.3.6	Slip clutch	8	
3.3.7	Suspension parts	8	
3.3.8	Travel trolleys.....	8	
3.4	Ordering of spare parts	8	
4	Measures for obtaining a safe period of operation	8	
4.1	How to determine the effective service life S.....	9	
4.1.1	Using with BDE	9	
4.1.2	Using without BDE	9	
4.2	General overhaul	9	

Spare parts / Ordering of spare parts

The correct order numbers for the original spare parts are to be taken from the spare parts list. Please ensure that you have the following data on your chain hoist to hand. Thereby a quick and correct supply of the parts required will be effected.

Electric chain hoist type :

Manufacture number :

Year of manufacture :

Load capacity :

Original spare parts for the electric chain hoist can be acquired from the following addresses:

1. Manufacturer

GIS AG
 Hebe- und Fördertechnik
 Luzernerstrasse 50
 CH-6247 Schötz

2. Agent

.....

.....

.....

.....

0 General directions

0.1 General safety directions

0.1.1 Safety and hazard precautions

The following symbols and terms are used in this instruction manual for safety and hazard instructions:



DANGER !

The non-compliance either in part or full of work and operational directions marked with this symbol can result in serious personal injury or even death. Danger notices must be **strictly** complied with.



CAUTION !

The non-compliance either in part or full of work and operational directions marked with this symbol can result in major machinery, property or material damage. Cautionary notices must be **strictly** adhered to.



NOTE

Effective and simple operation is the result of following the directions denoted under this symbol. "Note" directions make light work.

0.2 General safety specifications and procedures

The instruction manual for the electric chain hoist must be kept within the operating area of the hoist. Furthermore, supplementary to the instruction manual, the statutory regulations governing general accident prevention and environment protection are to be enforced. The operator must observe the following standards and regulations concerning construction, construction inspection and operation of electric chain hoists:

EC machinery directive	98/37/EC
EC low voltage directive	73/23/EEC
EC directive for electromagnetic compatibility	89/336/EEC; 92/31/EEC
EN 292, part 1 and 2	Safety of machinery
EN 60204-32	Electrical equipment of machines
IEC 34-1	Circulatory electric machines
IEC 34-5	IP protections
IEC 364	Electric installations
IEC 947-5-1	Low voltage control gears
EN 50081, 1, 2	Electromagnetic compatibility, emissions
EN 50082, 1, 2	Electromagnetic compatibility, interference immunity
FEM 9.511	Classification of mechanisms
FEM 9.671	Chains for lifting equipment
FEM 9.683	Selection of lifting and travel motors
FEM 9.751	Power driven series hoist mechanisms, safety
FEM 9.755	Measures for achieving safe working periods
FEM 9.761	Lifting force limiters
FEM 9.852	Standardised test procedure
FEM 9.941	Control symbols

Operating and service personnel must have read and understood the operating instructions, in particular the safety instructions, before commencing work. Protection gear for operating and service personnel must be made available and worn at all times.

The operator or its designate is responsible for the safety and hazard awareness of the operating personnel and are responsible for the supervision thereof.

0.2.1 Warning colour / Marking / Danger signs

- Lubricate chain figure 0-1
- CE symbol figure 0-2
- Model plate figure 0-3
- Data plate figure 0-4

0.3 Special safety directions

Transport and assembly:

- Electric chain hoists, single parts and large components are to be carefully affixed to suitable and technically acceptable hoisting apparatus / load lifting members

Connection:

- The connection work is only to be effected by personnel specifically designated and trained for the job

Start-up/operation:

- Before initial start-up, as well as daily start-up carry out a visual check and effect the predefined user-checks routine
 - Do not omit any serious safety procedure
 - Only put the electric chain hoist into operation when the available protection and safety apparatus is fully functional
 - Damage to the electric chain hoist and changes in its operational characteristics must be reported immediately to the person responsible
 - After use, or when in a non-operational mode, the chain hoist should be secured against unauthorised and unwarranted use
 - Transport of persons is not allowed
 - Moving loads above persons is not allowed
 - Persons are not allowed to remain below moving loads
 - Moving of overloads is not permitted
 - Do not pull the control cable
 - Always monitor and control the load
- See also adequate application (chapter 0.6)

Cleaning/service/repair/maintenance/refitting:

- For assembly work above body height, the necessary working platforms or ladders are to be made available
- Do not use machine parts for this purpose
- Check the electrical cable for chaff marks and damage
- For safety and environmental protection, trap and dispose of fuel or other agents used
- Safety apparatus that has been disassembled for the service or repair of the hoist must be reassembled and checked after the service and repair work has been completed
- The predefined testing and service intervals found in the instruction manual must be adhered to
- Directions found in the instruction manual, with regard to the exchange of parts are to be followed
- Operating personnel are to be informed before the commencement of special or refitting work
- The repair working area should be copiously secured
- During service or repair work, the electric chain hoist should be secured against unwarranted switching on
- Warning signs are to be placed
- The power cable is to be disconnected and secured against unwarranted connection
- Screw connections that have been loosened for repair or service work must be re-tightened
- Parts that are not reusable, such as O-rings, gaskets, self locking nuts, split-pins and washers are to be replaced

Shut down/storage:

- Before long periods of inactivity or storage, the chain hoist must be cleaned and preserved

0.4 Notes on hazard protection

Hazard areas must be clearly marked by warning signs and secured by isolation. It must be assured that the warnings regarding hazard areas are given due attention.

Hazards can stem from:

- inexpert application
- incomplete adherence to the safety directions
- incomplete or inexact execution of test and service work

0.4.1 Hazards caused by mechanical influences

Human injury:



DANGER !

Unconsciousness and injury through:

- crushing, shearing, cutting and twisting
- retraction, expulsion, ramming and rubbing
- slipping, stumbling and falling

Source:

- crush, shear and twist area
- breaching or bursting of parts

Protective possibilities:

- floor, equipment and machinery are to be kept clean
- eliminate leakages
- the safety distance must properly be observed

0.4.2 Hazards caused by electrical energy / power supply

Work on electrical apparatus or machinery may only be effected by qualified electricians or persons under the supervision and guidance of qualified electricians, in accordance with predefined electro-technical regulations.

Human injury:



DANGER !

Death through electrical shock, injury and burns through:

- contact
- faulty insulation
- faulty servicing or repair work
- short circuit

Source:

- contact with, touching of or standing too close to non-insulated power and voltage supply terminals
- free-lying electricity supply terminals following breakdown of insulation
- inadequate execution of safety checks following repair work
- incorrect fusing

Protection possibilities:

- machinery and equipment designated for repair or service work should be isolated before commencement of such work
- first check isolated parts for voltage
- regularly check the electrical fittings
- immediately change loose or damaged cables
- blown fuses must be replaced with fuses of the correct value
- avoid contact or touch with live terminals
- use only insulated tools

0.4.3 Sound level (SPL)

Tests on the chain hoists sound level are performed at a range of 1, 2, 4, 8 and 16 metres from the centre of the chain hoist motor to the measuring device.

Measurement of SPL according to DIN 45 635.

The SPL was measured:

- a) during operation of electric chain hoists on factory site
- b) during open-air operation

See table 0-1

0.5 Technical status

The present document was written in 1994. It corresponds to no. 1.7.4 and no. 4.4 of the appendage 1 in the version of the instructions of the European Parliament and the Council of 22.06.1998 (98/37/EC).

0.5.1 Technical datas

0.5.1.1 Models EM, EME, EHF, EMFE	table 0-2
0.5.1.2 Models EMK, EMS	table 0-3
0.5.1.3 Models EMHK, EMHTE, EMHTD, EMR	table 0-4
0.5.1.4 Special models	table 0-5

0.5.2 Recurrent checks

Each device/ unit operator has to adequately note all checks, maintenance and inspections performed into the inspection pass, and must have these confirmed by the competent person in charge. Incorrect or missing entries lead to forfeiture of the manufacturer's warranty.



CAUTION !

Devices and cranes are to be periodically tested by an expert. Basically, visual and functional checks are to be performed, whereby the condition of the components with regards to damage, wear, corrosion or other alterations are to be determined. Apart from this, the completeness and efficiency of the safety contrivance will be assessed. In order to correctly value wearing parts, it may be necessary to dismantle the equipment under inspection.



CAUTION !

The carrying means must be inspected in their entire length, which implies even covered or hidden parts.



CAUTION !

All periodical inspections are to be arranged by the operator.

0.6 Operational parameters

The electric chain hoists of the series EM are hoists of differing bearing capacities. They can be installed as stationary or mobile units. Electric chain hoists are manufactured in accordance with the latest technical developments along with the known technical safety regulations and specifications, and are tested for safety by the manufacturer.

Electric chain hoists are approved by various international institutes such as BG and others.

Electric chain hoists of the above mentioned series may only be used when in an acceptable technical condition, in accordance with their operating parameters, by safety and hazard conscious personnel.

The operational parameters of the electric chain hoist also encompass the compliance of the pre-defined operating, service and maintenance requirements laid down by the manufacturer.

The operational parameters do not include:

- exceeding the defined load capacity
- diagonal pulling of the load
- heaving, pulling or dragging of the load

See also chapter 0.3

Inching operations, ground mooring and driving against the limit switches should be avoided.

The manufacturer accepts no responsibility for damage to equipment and third parties ensuing from such action.

0.6.1 Directions for the use of the instruction manual

This instruction manual includes the following chapters:

- | | | | |
|---|-------------------------|---|---|
| 0 | General | 4 | Measures for obtaining a safe period of operation |
| 1 | Description | | |
| 2 | Start-up instructions | | |
| 3 | Service and maintenance | | |

Supplementary to the instruction manual, the following documentation from the operator must be noted:

- Declaration of conformity
- Inspection pass
- Spare parts list(s)
- Circuit diagrams

Page and figure numeration:

The pages are consecutively numbered. Empty pages are not numbered, however are calculated together with the consecutive pages.

Figures are numbered consecutively by chapter.

Example:

Figure 3-1 means: in chapter 3, figure 1

1 Description

General:

The EM series consist of the following models:

EM; EME; EMS; EMK; EMR; EMHK; EMHTE; EMHTD; EHF; EMFE

1.1 Operating conditions

Classification according to application requirements:

The electric chain hoists and travelling gears are classified according to the following regulations into FEM Groups:

- FEM 9.511; FEM 9.671
- DIN 15400 (load hook)
- FEM calculation regulations for series lifting equipment (chain drive, motor, full load-life span)
- FEM 9.755: D (1Am/Km 4) = 800 h
- Remarks about general revision (see chapter 4)

For the FEM Groups there is differing coefficient data that must be adhered to in operation.



CAUTION !

The travelling gear is always classified into the same FEM group as the corresponding electric chain hoist.



NOTE

The FEM Group registration number of the electric chain hoist can be found on the model plate.

The manufacturer will only guarantee the safety and lasting operation when the electric chain hoist is used for applications that fall within its valid FEM Group coefficient data.

Before the first start-up, the user has to estimate according to the features in table 1-1, which one of the four types of load is right for the use of the electric chain hoist during its whole service life. Table 1-2 shows standard values for the operating conditions of the FEM groups in dependence of the type of load and the time of operation.

Ascertainment of the correct type of application for an electric chain hoist:

The ascertainment of the correct type of application for the electric chain hoist can be gained from either the running time or from the expected type of load.



CAUTION !

Before the start-up operation of the electric chain hoist, it must be determined which of the load types shown in table 1-1 the electric chain hoist is to operate with. The classification of a load type, respectively a load collective (k), is for the complete operational life of the equipment and for operational safety reasons may not be altered.

Example 1:

Ascertainment of the permissible running time of the electric chain hoist:

A electric chain hoist of the FEM Group 1Am should, throughout its entire service life only be used for medium stress load tasks. This corresponds to the load type <3 heavy> (see table 1-1). Corresponding to the values in table 1-2, the electric chain hoist should not be used for longer than 0,5 - 1 hour per working day.

Example 2:

Ascertainment of the permissible load type:

An electric chain hoist of the FEM Group 2m should, throughout its complete service life be used for approximately 6 hours per working day. Thereby, the electric chain hoist should be operated in accordance with the characteristics of the load type <1 light> (see table 1-1).

1.2 General functional description

1.2.1 Control / Limit switches (figure 1-1 / 6, 7)

The electric chain hoists are fitted as standard with a 42 V low voltage control (electrically and mechanically interlocked). Limit switches are employed for the determination of the highest and lowest hook positions.

1.2.2 Control elements

The electric chain hoists have, as standard fitting, a control switch for the following function (figure 1-2):

- up / down
- up / down with emergency stop

Additionally, the following push button switches can be incorporated (figure 1-3):

- left / right
- emergency stop (red button)

1.2.3 Motor (figure 1-1 / 1)

Electric chain hoists are driven by cylindrical, squirrel cage motors. They correspond with the legal regulations and FEM calculation regulations for lifting equipment. The windings of the motor correspond to insulation class F.

1.2.4 Brake (figure 1-1 / 2)

The electric chain hoist is fitted with an AC multiple disc brake. The brake magnet is lifted and closed by means of the disc system's torque arm. In a de-energised mode the compression spring produces the braking torque.

1.2.5 Slip clutch (figure 1-1 / 3)

The asbestos-free slip clutch is found in the first gearing stage and operates as an overload safety device. It is adjusted to correspond to the specific load requirements of the FEM Group.

1.2.6 Gears (figure 1-1 / 4)

The two-stage or three-stage enclosed spur gearing are designed for lifting apparatus operations. The gear wheels with roller bearing are tempered and continuously lubricated. Through the helical gearing of the first gearing stage, running noise is reduced to a minimum.

1.2.7 Chain drive (figure 1-1 / 5)

The chain wheel and the guide roller are tempered and correspond with the FEM calculation regulations for series lifting equipment.

The high refractory, round steel chain corresponds to the grade DAT (8 SS) according to FEM 9.671. The load hook according to DIN 15400 is furnished with hook safety catch.

The system of protection of standard electric chain hoists corresponds to IP 54 according to DIN 40050.

1.2.8 Travel trolleys (figure 1-4)

- 1 side plate
- 2 spindle
- 2a bush
- 2b washer/large
- 2c washer/small
- 2d 6-kT nut
- 2e counter nut
- 3 counter weight
- 4a wheel flanges free of gearing
- 4b toothed wheel flanges
- 5 drive
- 6 control system
- 7 brake unit
- 8 control switch (figure 1-3)

2 Start-up



DANGER !

Mechanical adjustments may only be performed by authorized specialists.



CAUTION !

The operating staff must carefully read the operating instructions of the electric chain hoists before its initial operation and carry out all checks. Only when a safe operation has been established may the device be put into operation. Unauthorized persons may not operate the device or perform any work with the help of the same.

2.1 Transport and assembly

For the transport and assembly of the electric chain hoists, the safety direction for handling with loads are to be followed (see chapter 0.3).

The electric chain hoists must be assembled by qualified staff, always bearing in mind the accident prevention directions in chapter 0.2. Before assembly the electric chain hoist must be stored in an enclosed room or covered area.

Should the electric chain hoist be destined for operation outdoors, then it is recommended that a protection roof is erected to shield it from the influences of the weather.

Wherever possible, the electric chain hoist should be transported in its original packaging. It is recommended that the assembly and connection of the electric chain hoist is effected on-site by our qualified customer service personnel.

2.2 Connection

2.2.1 Power connection for operating voltage



DANGER !

Electro technical adjustments may only be performed by authorized specialists.



CAUTION !

Before connection of the electric chain hoist, check to ensure that the voltage defined on the load plate is the same as that which is available. Remove the electrical cover plate and connect the power cable in the side tapings (PG 21).

The electric chain hoist must be connected according to the supplied circuit diagrams.



NOTE

Opening the integrated clamp with a 3,5 mm wide screw driver, in accordance with figure 2-1.

2.2.2 Earth connections



DANGER !

The protective conductor is not to carry any power. With motor carriage operation, the power supply is enclosed in a terminal box of the drive motor. With the installation of a motor protector, the load plate voltage of the electric chain hoist must be noted.



NOTE

The earth conductor is wired up to the earth connection terminal as green/yellow wire. Earth conductor of the power supply to the terminal (PE) are connected with yellow/green wire.

2.2.3 Direction of rotation check



CAUTION !

The rotational direction must be in accordance with the symbols

Should this not be the case, then the two power cables (L1, L2) must be changed over.

2.2.4 Load chain



CAUTION !

Only use original chains.

Before start-up and during its operation the load chain must be oiled along its full length. The internal, contacting and rubbing surfaces of the chain links must have constant oil. Oiling can be effected by submersion or with an oil can, using a creeping gear oil. The end of the chain is to be affixed with a flexible piece of wire and fed through the chain wheel (1) of the electric chain hoist. Through short switching impulses, the chain (2) will be housed correctly in accordance with figure 2-2.



CAUTION !

Welded seams of the chain links must face inward on the chain wheel (see figure 2-2).



CAUTION !

Ensure that the limit stop assembly is properly fitted (see figure 2-3 A).

2.2.5 Chain bucket

- Run the chain out on the load side until the limit switch is activated
- Mount the chain bucket and let the chain run into it (chain must lie loosely in the bucket)



DANGER !

Any chain buckets made of sheet steel must be secured by means of a wire cable with min. 2 mm diameter (see figure 2-7). Latter has to be twisted twice on to the suspension part of the electric chain hoist.



NOTE

Should, by way of exception, no chain bucket be mounted, then the loose chain is affixed to the housing in accordance with figure 2-3 B.

2.2.6 Single fall operation

With single fall operation, the connection of the load hook (2) to the chain is effected in the middle of the shim (1) according to figure 2-4.



CAUTION !

Do not forget the assembly of the bolts (3)!
EM 200/EM 300/EM 500: observe correct arrangement of suspension (see figure 2-7).

2.2.7 Double fall operation

With double fall operation, the load side of the chain end is affixed in the chain port (1) of the housing using special screws (2), according to figure 2-5. It's only allowed to use original screws.

Bottom sheave (1) with load hook (2) according to figure 2-6 connection.



CAUTION !

- No twisting of the chain along its length!
- Use the correct screws for the securing of the chain end (see figure 2-5)!
- EM 200/EM 300/EM 500: observe correct arrangement of suspension (see figure 2-7).

2.2.8 Limit switch

The function of the limit switch (highest and lowest hook positions) must be checked during start-up operations.



NOTE

Should the lifting movement be regularly stopped by the limit switch, the electric hoist must then be fitted with a limit switch for "continuous operation".

2.3 Push travel trolley

Verifying carrying capacity:

The carrying capacity must at least correspond to that of the electric chain hoist.

How to mount the spindle:

The spindle is to be mounted from the inside to the outside, as shown in figure 1-4. When doing so, please observe that the number of washers (2c) is equally distributed on both sides.

For spindles with narrow flange widths, the two bushes (2a) are to be omitted.



CAUTION !

Clearance between wheel flanges (4a, 4b) and carrier may not exceed 1,5 mm. A washer (2c) must always be placed between the shield (1) and the 6 kT nut (2d). The torque of the 6 kT nut is to be observed by all means (see table 0-2). Screw on the counter nut (2e) hand tight, then tighten with a spanner by 1/4 or 1/2 of a rotation.



CAUTION !

No re-use possible for counter nut (2e) according to DIN 7967.

2.4 Electric travel trolley

For verification of carrying capacity and mounting of spindle, see chapter 2.3. The counter weight (3) is bolted to the side plate (1) with load wheels no teeth (4a), the drive (5) with the control system (6) to the side plate (1) with load wheels with teeth (4b).

A brake unit (7) can be retrofitted to all travel trolleys.

2.5 Further checks following assembly and installation

2.5.1 Check the fuses

Check the fuses in the tool box. The value of the fitted fuses must coincide with the values given in the table 0-2 technical datas for the appropriate motor type.



DANGER !

At no time use higher value fuses than stated in the table 0-2!

2.5.2 Electrical connection check

- Check electrical power supply run is safely seated and secure in its path
- Internal and external traction relief see figure 2-8



CAUTION !

- Avoid clamping, knotting and crushing of cable
- Check cable clamps and securing material are securely seated
- With external traction relief check the security of the traction relief cable for the control switch



CAUTION !

The traction relief cable must be so secured that the power cable for the control switch is not put under stress.

3 Service and maintenance

3.1 General regulations for service- and maintenance work

Operating failures on the electric chain hoists impairing the safe operation of the device are to be cleared immediately. The electric chain hoist may be only be serviced by trained and authorized specialists.



NOTE

We recommend to have maintenance work performed by our customer service.



CAUTION !

If the operator performs maintenance work on an electric chain hoist on his own account, the type of maintenance performed must be entered together with the date of performance into the inspection pass.

Alterations to, as well as changes of and supplements to the electric chain hoists which may impair the safety must be authorized by manufacturer in advance. Constructional alterations to the chain hoists not authorized by the manufacturer lead to an exclusion of the manufacturer's liability in case of damage.

Material warranty claims will only be recognized if solely genuine spare parts by the manufacturer have been employed.

We explicitly wish to point out that original parts and accessories not supplied on our behalf cannot be inspected or released by us.

General:

Service and maintenance are preventive measures designed to enhance the full functionality of the electric chain hoists. Non-compliance with the service and maintenance routines can result in reduction of the useful function of and/ or damage to the electric chain hoists.

Service and maintenance work is, in accordance with the instruction manual, to be effected at the predefined time intervals (table 3-1 and 3-2).

During service and maintenance work the general accident prevention directions, the special safety directions (chapter 0.3) as well as the notes on hazard protection (chapter 0.4) are to be followed.



DANGER !

Service and maintenance work is only to be effected on unloaded electric chain hoists. The main switch must be off. The lower sheave or the hook fittings must be lying on the floor or a maintenance platform.

The maintenance work encompass sight checks and cleaning routines.

The service work includes additional functional checks.

During the functional checks, all securing elements and cable clamps must be checked for secure seating.

Cables must be inspected for dirt, discoloration and arc spots.



CAUTION !

Used operating fuels (oil, lubricants ...) are to be safely collected and disposed of in an environmentally friendly manner.

Service and maintenance intervals are so defined:

t: daily
3 M: quarterly
12 M: annually

The predefined service and maintenance intervals are for standard operating hours. They are to be reduced when the loading of the electric chain hoist is on average large and when unfavourable conditions surface frequently during operation (dust, heat, humidity, steam etc.)

3.2 Maintenance

3.2.1 Maintenance summary

See table 3-1

3.3 Service

3.3.1 Service summary

See table 3-2

3.3.2 Brake system (figure 3-1)

In the power free mode, the brake must be able to hold the nominal load without any problems.

It has been operationally adjusted before delivery.



CAUTION !

Should the brake magnet (1) hum, buzz or vibrate, then the air gap (S) must be reset in accordance with table 3-3.



CAUTION !

Humming of the motor or slow achievement of lifting speed indicates oily or sticky brake discs (2) or the closing of the disc cage (3). Dismantle brake discs, clean and degrease. Disc cage to be replaced if damaged.



NOTE

By releasing the disc brake (careful pressure on the brake arm (4) figure 3-1), the load can be lowered in a manual mode.

Follow the correct installation procedure for the brake discs (see figure 3-3).

3.3.3 Load chain

The load chain is to be periodically checked for abrasion. The check is based upon three measurements.

- Accepted wear factors (table 3-4)
- Measurement points (figure 3-2)



CAUTION !

The chain is to be replaced when the measurements exceed those defined in the table. The chain wheel and chain guide are to be checked for wear at the same time, and, where necessary to be replaced. Only original chains are to be used. The chain links are not to be welded.

The installation of the new chain is effected in accordance with chapter 2.2.4.



NOTE

For ease of installation, the old chain and the new chain can be connected by a piece of flexible wire.

3.3.4 Limit switch



CAUTION !

Defect spring elements and rubber buffers are to be replaced.

Screw connections at the limit stop and shims resp. lower sheaves are to be checked and, where necessary, tightened to the right torque. For coefficient data see table 3-5.

3.3.5 Gears

The gearing has continual lubrication.

Lubrication fluid: ASEOL 10 - 52

Lubrication fluid quantity:	EM 25/EM 50	: 0,6 kg
	EM 100/EM 150	: 1,2 kg
	EM 200/EM 300	: 2,0 kg
	EM 500	: 2,0 kg

3.3.6 Slip clutch

The slip clutch is pre-adjusted.

The lining is wear resistant.



CAUTION !

An adjustment of the slip clutch may only be effected by qualified personnel and must be entered in the inspection pass.

3.3.7 Suspension parts

All statically loaded parts are known as suspension parts. Torque values (table 3-5) for screws of the tenacity class 8.8 according to DIN ISO 898.

3.3.8 Travel trolleys

The travel trolleys are more or less maintenance free.

The load wheels are to be occasionally inspected for wear and to be exchanged if necessary.

Unusual noises during daily operation are to be immediately reported to those in charge. Outstanding repair work must be performed instantly.

3.4 Ordering of spare parts

Notes on how to order spare parts can be found on page 2.

4 Measures for obtaining a safe period of operation

Statutory safety and health requirements of EU regulation 98/37/EC foresee an elimination of specific dangers which may arise from e.g. tiredness of ageing.

This requirement is also reflected in the activities of the ISO (TC96) and the CEN (TC147). According to this, the operator of serial lifting units is obliged to determine the actual utilization. The basis for this is provided by FEM 9.755 (06.93) "Measures for obtaining a safe period of operation of motor-driven serial lifting units (S.W.P.)".

The aim of this regulation is to determine measures for obtaining safe working periods for the entire service life, although from a technical point of view lifting units are subject to a certain endurance strength and premature failures cannot be totally excluded.

The following points have been taken from FEM rule 9.755:

1. Ascertainment of actual utilization arising from running time and load is to be documented at least once a year. Determination of the actual utilization is preferably to be performed with an BDE (Betriebsdatenerfassungs-Gerät = Production data collection system).
2. If no BDE is available, the running time T_i (operating hours) may be estimated or read with the help of a working hour meter.
3. If no BDE is available, the load Km_i (load collective) must be estimated.
4. The actual utilization S may be directly ascertained with the BDE. A general overhaul is required when the theoretical period of utilization has been reached (no limit to 10 years).
- 4.1 On determining the running time T_i with the help of an hour meter, the actual value of utilization must be multiplied with a multiplying factor $f=1,1$.
Actual utilization: $S = Km_i \times T_i \times 1,1$
- 4.2 On estimating the operating hours as well as load collective, the utilization determined in such a way must be multiplied with the factor $f=1,2$.
Actual utilization: $S = Km_i \times T_i \times 1,2$
5. General overhaul:
On reaching the theoretical service life, a general overhaul must be performed. On calculating the actual utilization according to 4.1 and 4.2, the general overhaul must be performed no later than 10 years afterwards, although the theoretical service life has not been reached. This restriction to 10 years does not apply when employing the BDE.
6. All inspections and the general overhaul are to be arranged by the operator of the hoist.

For electric chain hoists according to classification FEM 9.511, the following theoretical service life applies (calculated in full load hours):

1Bm	1Am	2m	3m	4m
400 h	800 h	1600 h	3200 h	6300 h

4.1 How to determine the effective service life S

4.1.1 Using with BDE

When using the BDE (Betriebsdatenerfassungs-Gerät = Production data collection system), our expert can directly ascertain the actual utilization and enter his results into the inspection pass. Such a form of collection corresponds to the actual utilization and is the easiest and the most cost-effective ascertainment of the real utilization.

4.1.2 Using without BDE

If no BDE is available, the effective service life S can be determined as such:

$$S = Km_i \times T_i \times f$$

Km_i : effective factor of load collective
 T_i : number of operating hours
 f : factor of collection type (1,1 or 1,2)

4.1.2.1 Assessing the load collective factor Km_i

The entire load of a lifting unit during an inspection interval is divided into 5 load collective groups:

Full load	$Km = 1^3$	= 1,0
¾-load	$Km = 0,75^3$	= 0,4219
½-load	$Km = 0,5^3$	= 0,125
¼-load	$Km = 0,25^3$	= 0,0156
0-load	Km	= 0,0

4.1.2.2 Determination of the number of operating hours (running time T_i)

The running time can be ascertained via a working hour meter or according to the following method:

Running time per inspection interval:

$$T_i = \frac{(\text{lifting} + \text{lowering}[m] \times (\text{cycles/h}) \times (\text{working time/day}[\text{h}]) \times (\text{days/insp.} - \text{interval}))}{60 \times \text{lifting speed}[m/\text{min}]}$$

4.1.2.3 Proportionate division of operating hours to the 5 load collectives

The operating hours determined or read under 4.1.2.2 must be proportionately assigned to the individual load collectives:

a %	full load	} (a + b + c + d + e = 100% T_i)
b %	¾-load	
c %	½-load	
d %	¼-load	
e %	no load	

4.1.2.4 Method of calculation

$$S = \underbrace{\left(\frac{a}{100} \times 1 + \frac{b}{100} \times 0,4219 + \frac{c}{100} \times 0,125 + \frac{d}{100} \times 0,0156 \right)}_{(Km_i)} \times T_i \times f$$

4.1.2.5 Documentation

The periodically calculated or read values are to be documented in the inspection pass.

4.2 General overhaul

On reaching the theoretical service life (no later than 10 years for collection without BDE), a general overhaul is to be performed. Hereby the device is put into a condition allowing a safe operation within another period of utilization (service life).

For this, components according to table 4-1 must be inspected and/or exchanged.

The inspection of as well as the approval for further utilization must be performed either by an expert company authorized by the manufacturer, or by the manufacturer personally.

The inspector determines: – the new possible theoretical utilization
 – the max. period until the next general overhaul

Such data is to be documented in the inspection pass.

Table 0-2-1

FEM classification	1Bm 150 s/h 25% duty	1Am 180 s/h 30% duty	2m 240 s/h 40% duty	3m 300 s/h 50% duty	4m 360 s/h 60% duty	Lifting speed	Motor power (1Bm)	3 x 400V 50Hz (1Bm)	1 x 230V 50Hz (2m)	No. of chain falls	Dead weight 3 m lift	Connection fuse
Types	Capacity [kg]					[m/min]	[kW]	[A]	[A]		[kg]	[A]
EM 25/1 N	250	200	200	160	125	8	0.36	1.6		1	17	10
EM 25/1 NF	250	200	200	160	125	8/1.5	0.36/0.07	3.0/1.6		1	18	10
EM 25/1 S	200	200	160	125	100	13	0.5	1.8		1	18	10
EM 25/1 SF	200	200	160	125	100	13/2	0.5/0.08	3.1/1.7		1	18	10
EM 25/1 N 1Ph	-	-	160	-	-	8	0.24 (2m)	-	4.2	1	17	10
EM 25/2 N	500	400	400	320	250	4	0.36	1.6		2	18	10
EM 25/2 NF	500	400	400	320	250	4/0.75	0.36/0.07	3.0/1.6		2	19	10
EM 25/2 S	400	400	320	250	200	6.5	0.5	1.8		2	18	10
EM 25/2 SF	400	400	320	250	200	6.5/1	0.5/0.08	3.1/1.7		2	19	10
EM 25/2 N 1Ph	-	-	320	-	-	4	0.24 (2m)	-	4.2	2	18	10
EM 50/1 N	500	400	320	320	250	9	0.82	2.1		1	18	10
EM 50/1 NF	500	400	320	250	250	9/1.5	0.82/0.14	3.5/1.7		1	19	10
EM 50/1 S	320	320	320	250	200	16	0.93	2.2		1	18	10
EM 50/1 SF	320	320	250	200	160	13/2	0.75/0.12	3.4/1.7		1	19	10
EM 50/1 N 1Ph	-	-	250	-	-	9	0.42 (2m)	-	4.9	1	18	10
EM 50/2 N	1'000	800	630	630	500	4.5	0.82	2.1		2	19	10
EM 50/2 NF	1'000	800	630	500	500	4.5/0.75	0.82/0.14	3.5/1.7		2	20	10
EM 50/2 S	630	630	630	500	400	8	0.93	2.2		2	20	10
EM 50/2 SF	630	630	500	400	320	6.5/1	0.75/0.12	3.4/1.7		2	20	10
EM 50/2 N 1Ph	-	-	500	-	-	4.5	0.42 (2m)	-	4.9	2	19	10
EM 100/1 N	1'000	800	630	630	500	8	1.45	3.7		1	36	10
EM 100/1 NF	1'000	800	630	630	500	8/2	1.45/0.36	4.0/2.8		1	40	10
EM 100/1 S	800	800	630	500	400	16	2.32	6.3		1	36	10
EM 100/1 SF	630	630	500	400	-	16/4.5	1.82/0.46	5.4/4.0		1	40	10
EM 100/2 N	2'000	1'600	1'250	1'250	1'000	4	1.45	3.7		2	38	10
EM 100/2 NF	2'000	1'600	1'250	1'250	1'000	4/1	1.45/0.36	4.0/2.8		2	42	10
EM 100/2 S	1'600	1'600	1'250	1'000	800	8	2.32	6.3		2	38	10
EM 100/2 SF	1'250	1'250	1'000	800	-	8/2.3	1.82/0.46	5.4/4.0		2	42	10
EM 150/1 N	1'000	1'000	800	800	630	8	1.45	3.7		1	37	10
EM 150/1 NF	1'000	1'000	800	800	630	8/2	1.45/0.36	4.0/2.8		1	41	10
EM 150/2 N	2'000	2'000	1'600	1'600	1'250	4	1.45	3.7		2	39	10
EM 150/2 NF	2'000	2'000	1'600	1'600	1'250	4/1	1.45/0.36	4.0/2.8		2	43	10
EM 200/1 N	1'600	1'600	1'250	1'000	1'000	8	2.42	6.0		1	63	16
EM 200/1 NF	1'600	1'250	1'000	1'000	800	8/1.6	2.42/0.5	6.6/4.2		1	65	16
EM 200/2 N	3'200	3'200	2'500	2'000	2'000	4	2.42	6.0		2	73	16
EM 200/2 NF	3'200	2'500	2'000	2'000	1'600	4/0.8	2.42/0.5	6.6/4.2		2	75	16
EM 300/1 N	2'000	2'000	1'600	1'250	1'250	8.2	3.1	7.3		1	65	16
EM 300/1 NF	2'000	1'600	1'250	1'250	1'000	8.2/1.8	3.1/0.64	8.0/4.5		1	67	16
EM 300/2 N	4'000	4'000	3'200	2'500	2'500	4.1	3.1	7.3		2	76	16
EM 300/2 NF	4'000	3'200	2'500	2'500	2'000	4.1/0.9	3.1/0.64	8.0/4.5		2	78	16
EM 500/1 N	2'500	2'000	1'600	1'600	1'250	6.3	3.1	7.7		1	65	16
EM 500/1 NF	2'500	2'000	1'600	1'600	1'250	6.3/1.5	3.1/0.64	8.2/4.4		1	67	16
EM 500/2 N	5'000	4'000	3'200	3'200	2'500	3.15	3.1	7.7		2	76	16
EM 500/2 NF	5'000	4'000	3'200	3'200	2'500	3.15/0.75	3.1/0.64	8.2/4.4		2	78	16

Table 0-2-2

FEM classification	1Bm 150 s/h 25% duty				Lifting speed	Motor power (1Bm)	3 x 400V 50Hz (1Bm)		No. of chain falls	Dead weight 3 m lift	Connection fuse
Types	Capacity [kg]				[m/min]	[kW]	[A]			[kg]	[A]
EME 25/1 N	250				8	0.36	1.6		1	17	10
EME 25/1 NF	250				8/1.5	0.36/0.07	3.0/1.6		1	18	10
EME 25/2 N	500				4	0.36	1.6		2	18	10
EME 25/2 NF	500				4/0.75	0.36/0.07	3.0/1.6		2	19	10
EME 50/2 N	1'000				4.5	0.82	2.1		2	19	10
EME 50/2 NF	1'000				4.5/0.75	0.82/0.14	3.5/1.7		2	20	10
EME 100/2 N	2'000				4	1.45	3.7		2	38	10
EME 100/2 NF	2'000				4/1	1.45/0.36	4.0/2.8		2	42	10

Table 0-2-3

FEM classification	1Bm 150 s/h 25% duty	1Am 180 s/h 30% duty	2m 240 s/h 40% duty	3m 300 s/h 50% duty	4m 360 s/h 60% duty	Travelling speed	Motor power	3 x 400V 50Hz	Torque	Dead weight	Connection fuse (EM+EMFE)
Types	Capacity [kg]					[m/min]	[kW]	[A]	[Nm]	[kg]	[A]
EHF 50	1'000	800	630	630	500	-	-	-		7.5	-
EMFE 50/N	1'000	800	630	630	500	12	0.25	0.8	130	27	10
EMFE 50/NF	1'000	800	630	630	500	12/4	0.15/0.045	0.65/0.75	to	27	10
EMFE 50/SF	800	800	630	630	500	20/6	0.15/0.045	0.65/0.75	150	27	10
EHF 150	2'000	2'000	1'600	1'600	1'250	-	-	-		13.5	-
EMFE 150/N	2'000	2'000	1'600	1'600	1'250	12	0.25	0.8	320	31	10
EMFE 150/NF	2'000	2'000	1'600	1'600	1'250	12/4	0.15/0.045	0.65/0.75	to	31	10
EMFE 150/SF	1'600	1'600	1'600	1'600	1'250	20/6	0.15/0.045	0.65/0.75	540	31	10
EHF 300	4'000	4'000	3'200	2'500	2'500	-	-	-		27.5	-
EMFE 300/N	4'000	4'000	3'200	2'500	2'500	12	0.25	0.8	430	50	16
EMFE 300/NF	4'000	4'000	3'200	2'500	2'500	12/4	0.15/0.045	0.65/0.75	to	50	16
EMFE 300/SF	3'200	3'200	3'200	2'500	2'500	20/6	0.15/0.045	0.65/0.75	500	50	16
EHF 500	5'000	4'000	3'200	3'200	2'500	-	-	-		27.5	-
EMFE 500/N	5'000	4'000	3'200	3'200	2'500	12	2x0.25	2x0.8	430	57	16
EMFE 500/NF	5'000	4'000	3'200	3'200	2'500	12/4	2x0.15/0.045	2x0.65/0.75	to	57	16
EMFE 500/SF	4'000	4'000	3'200	3'200	2'500	20/6	2x0.15/0.045	2x0.65/0.75	500	57	16

Table 0-1

Types	Measurement Measuring dist.	dBA				
		1 m	2 m	4 m	8 m	16 m
EM 25 EME 25	a)	75	72	69	66	63
	b)	75	69	63	57	51
EM 50 EME 50	a)	79	76	73	70	67
	b)	79	73	67	61	55
EM 100 EME 100	a)	74	71	68	65	62
	b)	74	68	62	56	50
EM 150	a)	75	72	69	66	63
	b)	75	69	63	57	51
EM 200	a)	79	76	73	70	67
	b)	79	73	67	61	55
EM 300	a)	80	77	74	71	68
	b)	80	74	68	62	56
EM 500	a)	79	76	73	70	67
	b)	79	73	67	61	55

Table 1-2

FEM group according to FEM 9.511	1Bm	1Am	2m	3m	4m
Type of load	Medium running time per working day [h]				
1 - light $k < 0.50$	up to 2	2 - 4	4 - 8	8 - 16	over 16
2 - medium $0.50 < k < 0.63$	up to 1	1 - 2	2 - 4	4 - 8	8 - 16
3 - heavy $0.63 < k < 0.80$	up to 0.5	0.5 - 1	1 - 2	2 - 4	4 - 8
4 - very heavy $0.80 < k < 1$	up to 0.25	up to 0.5	0.5 - 1	1 - 2	2 - 4

Table 3-5

Dimension	Torque [Nm]
M 5	6
M 6	10
M 8	24
M 10	48
M 12	83

Table 3-3

Brake type	Air gap S [mm]	Number of discs	
		internal	external
EM 25	1.5 - 2	4	5
EM 50	1.5 - 2	5	6
EM 100	1.5 - 2	7	8
EM 150	1.5 - 2	7	8
EM 200	1.5 - 2	7	8
EM 300	1.5 - 2	8	9
EM 500	1.5 - 2	8	9

Table 4-1

Components of EM-models, all types	Check for wear *	Exchange
Brake	x	
Motor shaft	x	
Gear teeth	x	
Antifriction bearing		x
Washers		x
Chain	x **	
Chain wheel, chain guide	x	
Deflection wheels	x	
Suspension	x	
Load hook		x
Travelling gear, running wheel	x	
Contactors, limit switch	x	

* exchange when worn

** exchange no later than at general overhaul

Table 1-1

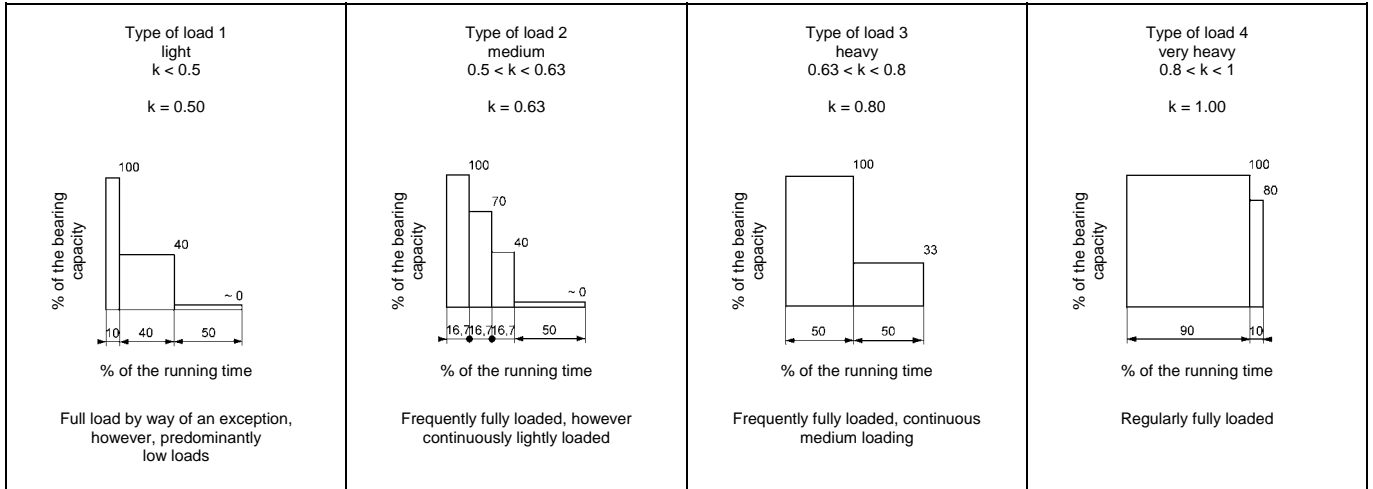

k = Type of load (load collective)

Table 3-1

Term	t	3 M	12 M	Activity	Notes
1 Load chain	X			visual check clean and oil as needed	see chapter 2.2.4
2 Hoist and carriage	X			excess noise check seal check	
3 Power supply cable	X			visual check	
4 Limit switch	X			function check	see chapter 2.2.8
5 Seal		X		visual check	
6 Cable discharging device control cable	X			visual check	

Table 3-2

Term	t	3 M	12 M	Activity	Notes
1 Load chain		X	X	oiling measure abrasion	see chapter 2.2.4 / 3.3.3
2 Brake system	X		X	function check with load	see chapter 3.3.2
3 Electrical fittings			X	function check	
4 Securing screws on suspended parts and load hook with accessories			X	check for cracks check screw movement	see chapter 3.3.7
5 Gearing			X	visual check abrasion	see chapter 3.3.5
6 Limit switch			X	check switching elements	see chapter 3.3.4

Table 3-4

		EM 25	EM 50	EM 100	EM 150	EM 200	EM 300 / EM 500
Chain type d x t	[mm]	4 x 12.3	5 x 15.3	7 x 22	8 x 22	9 x 27	10 x 28
Tolerances in accordance with: DIN 685, part 5 FEM 9.671							
1. Measurement over 11 chain links; a = 11t	[mm]	138.0	171.6	246.8	246.8	302.9	314.2
2. Measurement over 1 chain link 1t	[mm]	12.9	16.0	23.1	23.1	28.35	29.4
3. Measurement of the chain link diameter							
$dm = \frac{d1 + d2}{2}$; (dm min. = 0.9 x d)	[mm]	3.6	4.5	6.3	7.2	8.1	9.0

Figure 0-1

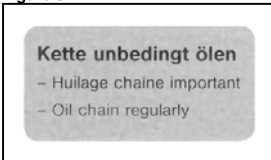

Figure 0-2



Figure 0-3

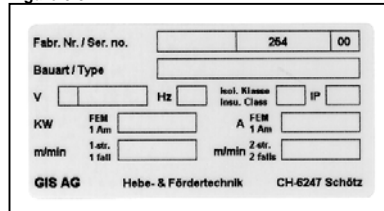

Figure 0-4

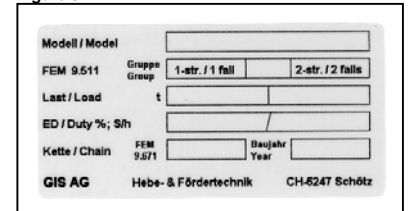

Figure 1-1

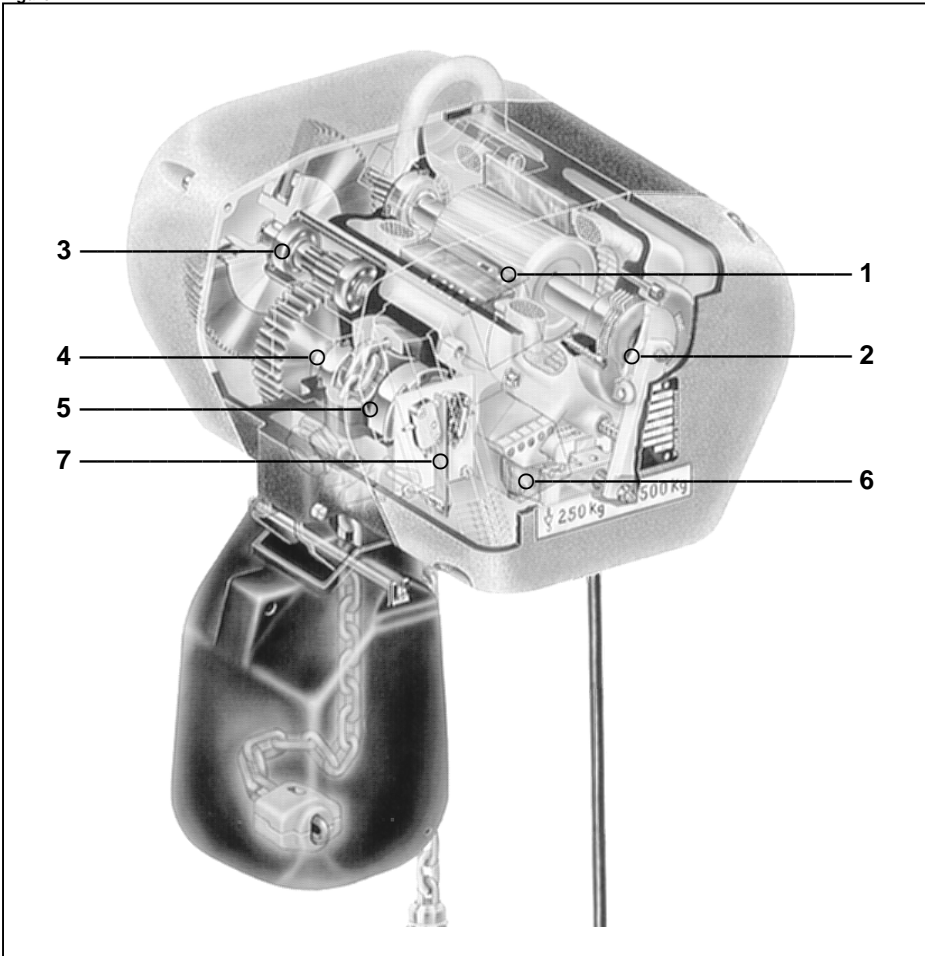

Figure 1-2

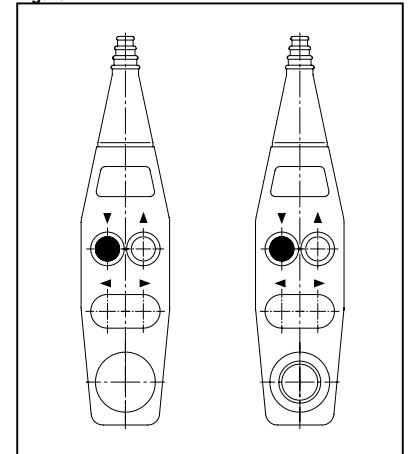

Figure 1-3

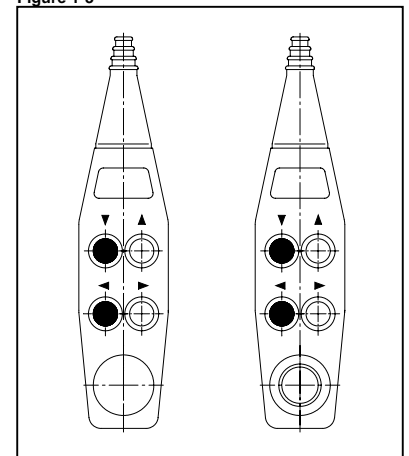

Figure 1-4

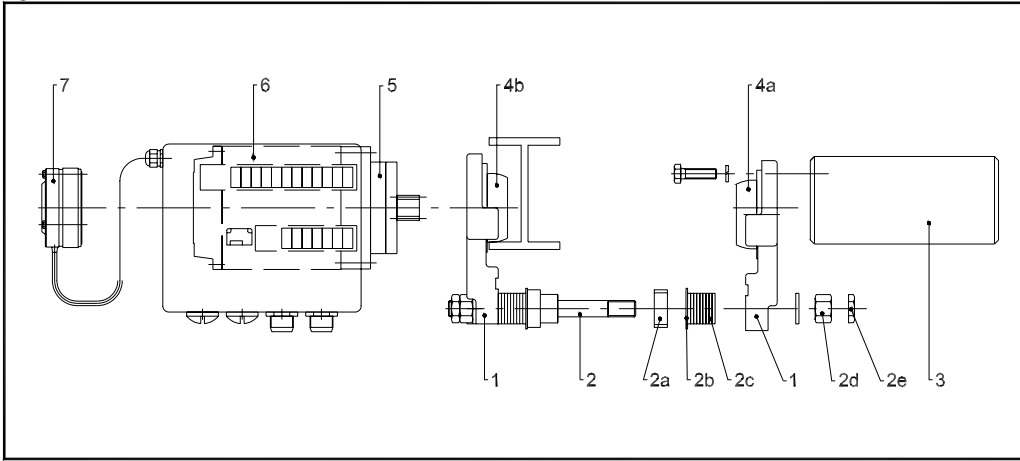

Figure 2-1

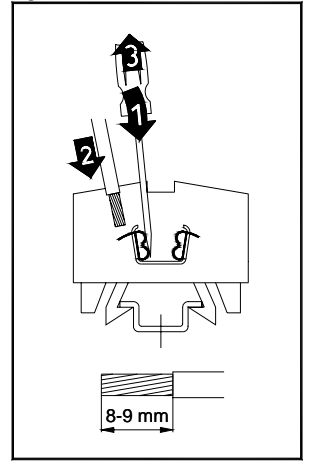

Figure 2-2

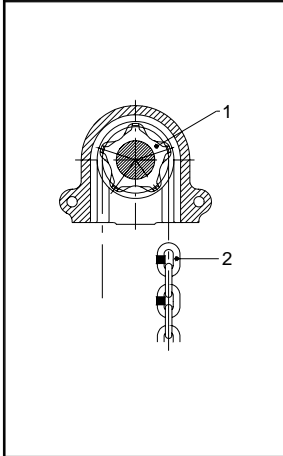

Figure 2-3

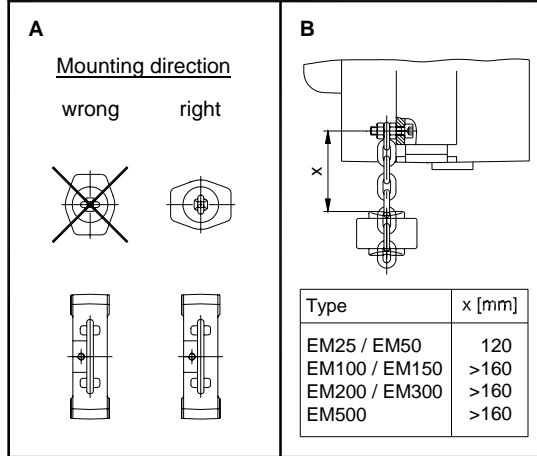

Figure 2-4

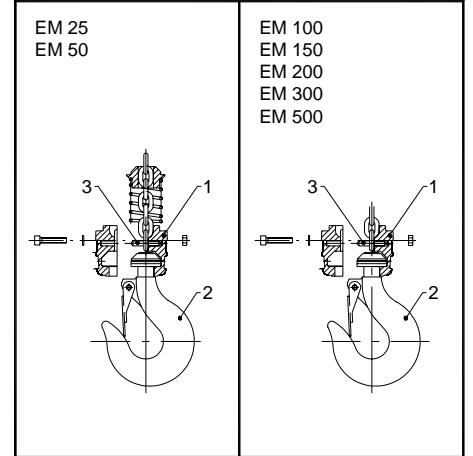

Figure 2-5

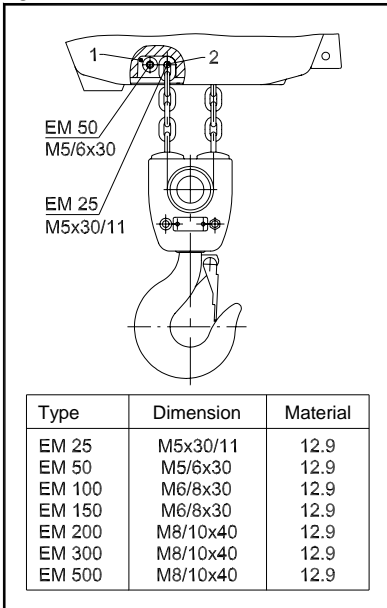

Figure 2-6

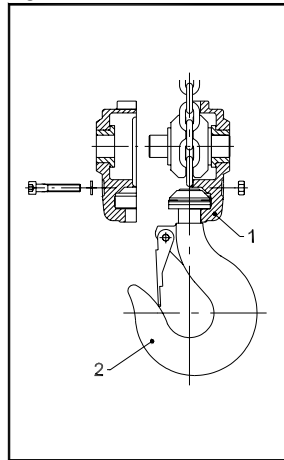

Figure 2-7

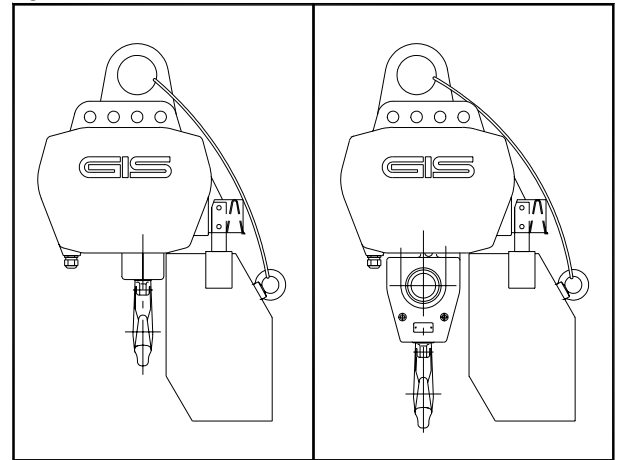

Figure 2-8

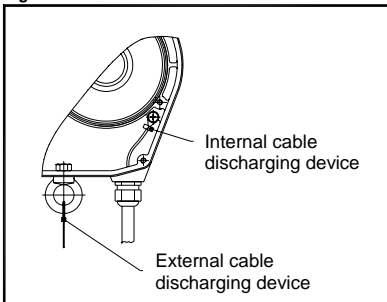

Figure 3-1

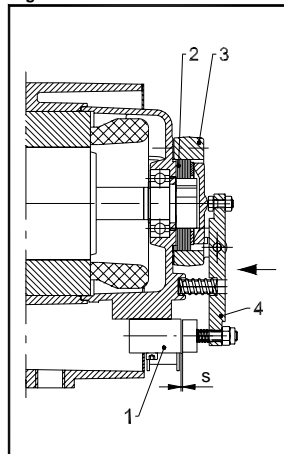

Figure 3-2

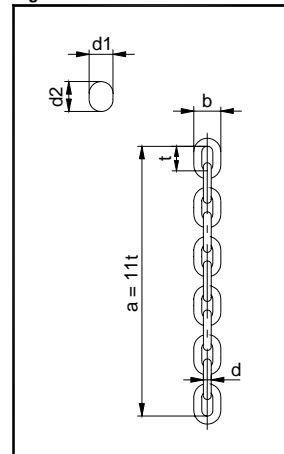

Figure 3-3

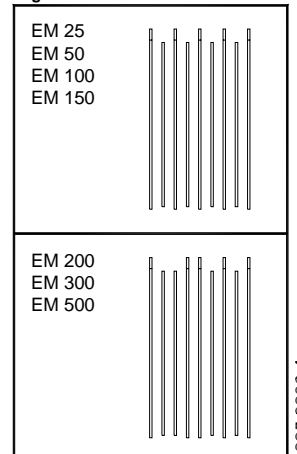

Table 0-3-1

FEM classification	1Am 180 s/h 30% duty	2m 240 s/h 40% duty	3m 300 s/h 50% duty	4m 360 s/h 60% duty	Lifting speed	Motor power (1Am)	3 x 400V 50Hz (1Am)	No. of chain falls	Dead weight 3 m lift	Connection fuse
Types	Capacity [kg]				[m/min]	[kW]	[A]		[kg]	[A]
EMK 25/1 N	160	160	125	100	8	0.3	1.6	1	35	10
EMK 25/1 NF	160	160	125	100	8/1.5	0.3/0.05	2.9/1.6	1	35	10
EMK 25/1 S	160	125	100	-	13	0.5	1.8	1	35	10
EMK 25/1 SF	160	125	100	-	13/2	0.5/0.08	3.1/1.7	1	35	10
EMK 25/2 N	320	320	250	200	4	0.3	1.6	2	37	10
EMK 25/2 NF	320	320	250	200	4/0.75	0.3/0.05	2.9/1.6	2	37	10
EMK 25/2 S	320	250	200	-	6.5	0.5	1.8	2	37	10
EMK 25/2 SF	320	250	200	-	6.5/1	0.5/0.08	3.1/1.7	2	37	10
EMK 50/1 N	320	250	250	200	9	0.65	1.9	1	36	10
EMK 50/1 NF	320	250	200	200	9/1.5	0.52/0.09	3.3/1.7	1	36	10
EMK 50/1 S	250	250	200	160	16	0.93	2.2	1	36	10
EMK 50/1 SF	250	200	160	125	13/2	0.75/0.12	3.4/1.7	1	36	10
EMK 50/2 N	630	500	500	400	4.5	0.65	1.9	2	38	10
EMK 50/2 NF	630	500	400	400	4.5/0.75	0.52/0.09	3.3/1.7	2	38	10
EMK 50/2 S	500	500	400	320	8	0.93	2.2	2	38	10
EMK 50/2 SF	500	400	320	250	6.5/1	0.75/0.12	3.4/1.7	2	38	10
EMK 100/1 N	630	500	500	400	8	1.16	3.3	1	86	10
EMK 100/1 NF	630	500	500	400	8/2	1.16/0.29	3.3/2.8	1	86	10
EMK 100/1 S	630	500	400	-	16	2.32	6.3	1	84	10
EMK 100/1 SF	500	400	-	-	16/4.5	1.82/0.46	5.4/4.0	1	85	10
EMK 100/2 N	1'250	1'000	1'000	800	4	1.16	3.3	2	92	10
EMK 100/2 NF	1'250	1'000	1'000	800	4/1	1.16/0.29	3.3/2.8	2	93	10
EMK 100/2 S	1'250	1'000	800	-	8	2.32	6.3	2	90	10
EMK 100/2 SF	1'000	800	-	-	8/2.3	1.82/0.46	5.4/4.0	2	92	10
EMK 150/1 N	800	630	630	500	8	1.45	3.7	1	96	10
EMK 150/1 NF	800	630	630	500	8/2	1.45/0.36	4.0/2.8	1	96	10
EMK 150/2 N	1'600	1'250	1'250	1'000	4	1.45	3.7	2	104	10
EMK 150/2 NF	1'600	1'250	1'250	1'000	4/1	1.45/0.36	4.0/2.8	2	105	10
EMK 200/1 N	1'250	1'000	800	800	8	2.42	6.0	1	130	16
EMK 200/1 NF	1'000	800	800	630	8/1.6	1.89/0.39	5.5/4.1	1	131	16
EMK 200/2 N	2'500	2'000	1'600	1'600	4	2.42	6.0	2	135	16
EMK 200/2 NF	2'000	1'600	1'600	1'250	4/0.8	1.89/0.39	5.5/4.1	2	136	16
EMK 300/1 N	1'600	1'250	1'000	1'000	8.2	3.1	7.3	1	135	16
EMK 300/1 NF	1'250	1'000	1'000	800	8.2/1.8	2.48/0.51	6.6/4.2	1	136	16
EMK 300/2 N	3'200	2'500	2'000	2'000	4.1	3.1	7.3	2	140	16
EMK 300/2 NF	2'500	2'000	2'000	1'600	4.1/0.9	2.48/0.51	6.6/4.2	2	141	16

Table 0-3-2

FEM classification	1Am 180 s/h 30% duty	2m 240 s/h 40% duty	3m 300 s/h 50% duty	4m 360 s/h 60% duty	Lifting speed	Motor power (1Am)	3 x 400V 50Hz (1Am)	No. of chain falls	Dead weight 3 m lift	Connection fuse
Types	Capacity [kg]				[m/min]	[kW]	[A]		[kg]	[A]
EMS 50/1 N	2x160	2x125	2x125	2x100	8	0.6	1.9	1	53	10
EMS 50/1 NF	2x160	2x125	2x100	2x100	8/1.2	0.6/0.09	3.3/1.7	1	53	10
EMS 50/1 S	2x125	2x125	2x100	-	13	0.74	2.2	1	53	10
EMS 50/1 SF	2x125	2x100	-	-	10/1.5	0.57/0.09	3.1/1.6	1	53	10
EMS 50/2 N	2x320	2x250	2x250	2x200	4	0.6	1.9	2	56	10
EMS 50/2 NF	2x320	2x250	2x200	2x200	4/0.6	0.6/0.09	3.3/1.7	2	56	10
EMS 50/2 S	2x250	2x250	2x200	-	6.5	0.74	2.2	2	56	10
EMS 50/2 SF	2x250	2x200	-	-	5/0.75	0.57/0.09	3.1/1.6	2	56	10
EMS 100/1 N	2x320	2x250	2x250	2x200	8	1.16	3.3	1	95	10
EMS 100/1 NF	2x320	2x250	2x250	2x200	8/2	1.16/0.29	3.3/2.8	1	95	10
EMS 100/1 S	2x320	2x250	2x200	-	16	2.32	6.3	1	93	10
EMS 100/1 SF	2x250	2x200	-	-	16/3.2	1.82/0.46	3.3/2.8	1	94	10
EMS 100/2 N	2x630	2x500	2x500	2x400	4	1.16	3.3	2	100	10
EMS 100/2 NF	2x630	2x500	2x500	2x400	4/1	1.16/0.29	3.3/2.8	2	101	10
EMS 100/2 S	2x630	2x500	2x400	-	8	2.32	6.3	2	98	10
EMS 100/2 SF	2x500	2x400	-	-	8/1.6	1.82/0.46	3.3/2.8	2	100	10
EMS 200/1 N	2x630	2x500	2x400	2x400	8	2.42	6.0	1	155	16
EMS 200/1 NF	2x500	2x400	2x400	-	8/1.6	1.89/0.39	5.5/4.1	1	156	16
EMS 200/2 N	2x1'250	2x1'000	2x800	2x800	4	2.42	6.0	2	160	16
EMS 200/2 NF	2x1'000	2x800	2x800	-	4/0.8	1.89/0.39	5.5/4.1	2	161	16

Table 0-4-1

Types	FEM classification 2m 240 s/h, 40% duty	Eccentric load [Nm]	Lifting speed [m/min]	Motor power [kW]	3 x 400V 50Hz [A]	Delivered lifting heights				Dead weight [kg]	Connection fuse [A]
	Capacity [kg]					[m]					
EMHK 125/- NF	125	-	16/2.5	0.38/0.06	3.0/1.7	3	4	-	-	27	10
EMHK 125/- SF	125	-	24/4	0.59/0.09	3.2/1.6	3	4	-	-	27	10
EMHK 250/- NF	250	-	9/1.5	0.4/0.07	2.9/1.6	3	4	-	-	27	10
EMHK 250/- SF	250	-	13/2	0.59/0.09	3.2/1.6	3	4	-	-	27	10
EMHTE 125/- NF	125	150	16/2.5	0.38/0.06	3.0/1.7	0.8	1.2	1.5	2	27	10
EMHTE 125/- SF	125	150	24/4	0.59/0.09	3.2/1.6	0.8	1.2	1.5	2	27	10
EMHTE 250/- NF	250	300	9/1.5	0.4/0.07	2.9/1.6	-	1.2	1.5	2	27	10
EMHTE 250/- SF	250	300	13/2	0.59/0.09	3.2/1.6	-	1.2	1.5	2	27	10
EMHTD 125/- NF	125	150	16/2.5	0.38/0.06	3.0/1.7	0.8	1.2	1.5	2	27	10
EMHTD 125/- SF	125	150	24/4	0.59/0.09	3.2/1.6	0.8	1.2	1.5	2	27	10
EMHTD 250/- NF	250	300	9/1.5	0.4/0.07	2.9/1.6	-	1.2	1.5	2	27	10
EMHTD 250/- SF	250	300	13/2	0.59/0.09	3.2/1.6	-	1.2	1.5	2	27	10

Chain: 5 x 15.3 mm
Continuously rated limit switch

Table 0-4-2

Types	FEM classification 1Am 180 s/h, 30% duty	FEM classification 2m 240 s/h, 40% duty	Lifting speed [m/min]	Motor power (1Am/2m) [kW]	3 x 400V 50Hz (1Am/2m)	3 x 420V 50Hz (1Am/2m)	No. of chain falls	Dead weight 3 m lift [kg]	Connection fuse [A]
	Capacity [kg]	Capacity [kg]			[A]	[A]			
EMR 50/1 N	320	250	9	0.52	1.8	1.8	1	20	10
EMR 50/1 NF	320	250	9/1.5	0.52/0.09	3.1/1.6	2.7/1.5	1	22.5	10
EMR 50/2 N	630	500	4.5	0.52	1.8	1.8	2	22.5	10
EMR 50/2 NF	630	500	4.5/0.75	0.52/0.09	3.1/1.6	2.7/1.5	2	25	10
EMR 100/1 N	-	500	8	0.91	3.1	3.1	1	38.5	10
EMR 100/1 NF	-	500	8/2	0.91/0.23	2.8/2.6	2.8/2.6	1	44	10
EMR 100/2 N	-	1'000	4	0.91	3.1	3.1	2	44	10
EMR 100/2 NF	-	1'000	4/1	0.91/0.23	2.8/2.6	2.8/2.6	2	49	10

Stainless steel chain: EMR 50: 5 x 15.3 mm
EMR 100: 7 x 22 mm
Geared limit switch for all models