

LEGUAN®

160

Operators and Service Manual 04/2015-

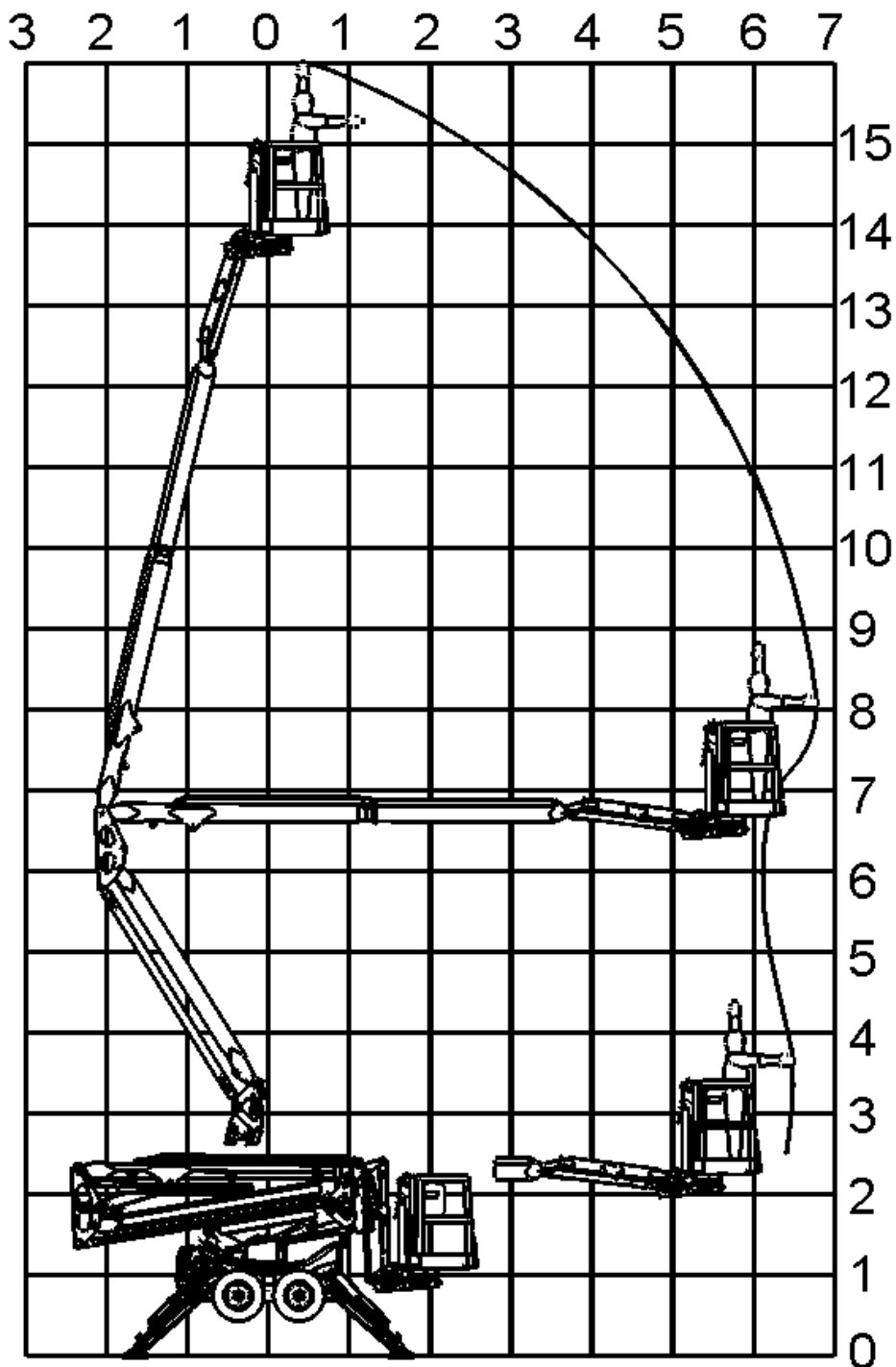

TABLE OF CONTENTS

	page
1. INTRODUCTION AND WARRANTY CONDITIONS	4
1.1 INTRODUCTION	4
1.2 WARRANTY CONDITIONS	4
EC DECLARATION OF CONFORMITY	6
2. GENERAL INFORMATION	7
3. TECHNICAL SPECIFICATION, LEGUAN 160	8
3.1 REACH DIAGRAM	9
4. SIGNS AND STICKERS	10
5. SAFETY INSTRUCTIONS	11
5.1 BEFORE STARTING OPERATION	11
5.2 RISK OF TIPPING OVER	12
5.3 RISK OF FALLING	12
5.4 RISK OF COLLISION	12
5.5 RISK OF ELECTRIC SHOCK	13
5.6 RISK OF EXPLOSION / FIRE	13
5.7 DAILY INSPECTION BEFORE STARTING OPERATION	13
6. CONTROLS AND SWITCHES	14
6.1 CONTROLS AT PLATFORM	14
6.2 CONTROLS AT GROUND LEVEL	15
6.2.1 <i>Battery disconnect switch at ground level</i>	15
6.2.2 <i>Controls on the valve box at ground level</i>	15
6.2.3 <i>Emergency lowering buttons at ground level</i>	15
6.2.4 <i>230V - Connection and switches (Option)</i>	16
6.2.5 <i>Lower controls (Option)</i>	16
7. STARTING THE ENGINE / ELECTRIC MOTOR	16
8. DRIVE CONTROL	18
8.1 DEFINING THE GRADIENT OF THE SLOPE	19
8.2 CRAWLER TRACK CHASSIS	20
8.2.1 <i>Instructions for working environment</i>	20
8.2.2 <i>Operating instructions</i>	21
9. OPERATION OF THE OUTRIGGERS	21
10. OPERATION OF THE BOOMS	22
11. EMERGENCY LOWERING	23
12. ENDING THE OPERATION	23
13. TRANSPORTING INSTRUCTIONS	24
14. SERVICE, MAINTENANCE AND INSPECTION INSTRUCTIONS	25
14.1 GENERAL INSTRUCTIONS	25
14.2 SERVICES AND CHECKS, MAINTENANCE SCHEDULE	27
15. SERVICE INSTRUCTIONS	28
15.1 GREASING OF THE MACHINE	28
15.2 HANDLING OF FUEL AND REFUELING	28
15.3 HYDRAULIC OIL AND OIL FILTER CHANGE	28
15.4 HYDRAULIC OIL LEVEL	28
15.5 BATTERY CHECK	28
15.6 CHECK OF SET UP OUTRIGGER CONTROL SYSTEM	29
15.7 WATER LEVEL CHECK	29
15.8 ADJUSTMENTS IN HYDRAULIC SYSTEM	29
15.9 COMPONENTS IN OVERLOAD CONTROL SYSTEM	30
15.10 CHECK AND ADJUSTMENT OF TRACK TENSION	31

16. REPAIR INSTRUCTIONS	32
16.1 WELDING	32
17. INSTRUCTIONS FOR TEMPORARY STORAGE	32
18. TROUBLESHOOTING	33
19. SERVICES MADE	36

ATTACHMENTS :
Hydraulic schematic
Electric schematic

1. INTRODUCTION AND WARRANTY CONDITIONS

1.1 Introduction

LEGUAN LIFTS wants to thank you for purchasing this Leguan access platform. It is the result of Leguan's long experience in design and manufacturing of access equipment. We ask you that you read and understand the contents of this manual completely before operating the access platform. This will improve your operating and maintenance efficiency, help avoid breakdowns and damage and extend your machine's life.



Pay special attention to this symbol. It indicates important safety factors that require special attention. Every operator must read and understand this manual before starting operation, and the instructions in this manual must be followed. If you are lending the access platform out to somebody, make sure that he familiarises himself with and understands these instructions. If there is anything unclear with the operation please contact your Leguan dealer.

If spare parts are needed, use only original LEGUAN parts. They will provide your machine with the maximum life expectancy and ensure optimum safety.

The manufacturer does not warrant any damages which are the result of using the access platform.

It is not possible to give explicit operating instructions to all operating conditions of the machine. Therefore the manufacturer is not responsible for any damage caused by eventual faults in this Operators Manual.

The manufacturer does not accept any responsibility for consequential losses resulting from the use of this self propelled access platform.

1.2 Warranty conditions

This product is warranted for a period of twenty-four (24) months.

Warranty covers manufacturing and material defects. All warranty obligations end when the warranty period ends. Warranty repair that has been started will be completed regardless of the ending date of warranty period.

A condition for the warranty is that both the buyer and the seller have accepted the delivery. If the buyer is not present when the delivery takes place and doesn't make a complaint within 14 days of delivery of this access platform, it is considered that the sale is closed and the warranty period has started.

Warranty is limited to the repair of a faulty access platform without cost at an authorized Leguan service workshop. Warranty period for parts that are changed in connection with the repair will end when the warranty period for the access platform ends. Parts that have been changed in the warranty repair will remain Leguan Lifts' property without compensation.

Warranty does not cover:

- damages caused by wrong or negligent use of this product, or mischief
- any repairs or modifications to the product, performed without the prior authorisation of the manufacturer
- damages caused by not following service and maintenance instructions
- adjustments, repairs and spare parts replacements caused by normal wear
- damages caused by excessive loads on the access platform, sudden unexpected incident, natural disaster
- damages caused by external mechanical or chemical reasons (paint damages, especially caused by stone chips, air and environmental pollution and strong cleaning agents)
- eventual visible patterns or unevenness of painted surfaces
- warranty claims that haven't been sent to the manufacturer within 14 days from the date the buyer has noticed the defect. In all conditions the buyer shall act so that his action doesn't make the eventual defect(s) worse

The manufacturer does not accept any responsibility for consequential losses resulting from the use of this access platform.

In the event a fault occurs which is attributable to manufacturing or assembly defect, contact the dealer without delay.

**ALKUPERÄINEN EY-VAATIMUSTENMUKAISUUSVAKUUTUS
ORIGINAL EC DECLARATION OF CONFORMITY FOR MACHINERY****TÄTEN VAKUUTAMME, ETTÄ
HEREWITH DECLARES THAT**

HENKILÖNOSTIN AERIAL PLATFORM	LEGUAN	NIMELLISKUORMA NOMINAL LOAD	200 KG
MALLI MODEL	L160M1	NOSTOKORKEUS PLATFORM HEIGHT	13,9 M
SARJANUMERO SERIAL NR	00XXXXX	VALMISTUSVUOSI CONSTRUCTION	201X

**ON KONEDIREKTIIVIN 2006/42/EY ASIAAN KUUULUVIEN SÄÄNNÖSTEN MUKAINEN
IS IN ACCORDANCE WITH THE REGULATIONS LAID OUT IN THE MACHINERY
DIRECTIVE: 2006/42 / EC**

**KONE TÄYTTÄÄ LISÄKSI MUIDEN EY-DIREKTIIVIN VAATIMUKSET: 2004/108/EY THE
MACHINE ALSO FULFILLS THE REQUIREMENTS LAID OUT IN THE DIRECTIVES
2004/108/EY**

**SEURAAVIA EUROOPPALAISIA YHDENMUKAISIA STANDARDEJA ON SOVELLETTU
SUUNNITTELUSSA: EN280:2013
FOLLOWING EUROPEAN HARMONIZED STANDARDS ARE USED WHEN
THE MACHINERY WAS DESIGNED: EN280:2013**

Teknisen tiedoston on valtuutettu kokoamaan:
Storage address of original documents:

LEGUAN LIFTS OY
Ylötie 1, FI-33470 Ylöjärvi, Finland

Ilmoitettu laitos/Notified Body

INSPECTA TARKASTUS OY, NB0424

Testausraportti/Test Report

No. 10537/1

Paikka / Place, Päiväys / Date
Ylöjärvi, FINLAND

xx.xx.2015

Valmistaja / Manufacturer:

LEGUAN LIFTS OY
Ylötie 10, FI-33470 Ylöjärvi, Finland

XXXXX

Toimitusjohtaja / Managing Director

2. GENERAL INFORMATION

LEGUAN 160 is a self propelled Mobile Elevating Work Platform – or commonly called access platform, designed for indoor and outdoor use. An access platform is destined for lifting of persons and their equipment only. It is not allowed to use an access platform as a crane.

LEGUAN is designed and built in accordance with the international safety standards and MEWP (Mobile Elevating Work Platforms) standards.

The picture below shows the main parts of this access platform:

- | | |
|---|--------------------------------------|
| 1. Chassis | 13. Self levelling bar 2 |
| 2. Transmission, either with wheels or with crawler tracks | 14. Lower boom 2 |
| 3. Outrigger | 15. Linkage piece 2 |
| 4. Outrigger cylinder | 16. Upper boom cylinder |
| 5. Slewing ring | 17. Self levelling "slave" cylinder |
| 6. Connection box of control system with emergency lowering buttons | 18. Telescoping cylinder |
| 7. Self levelling bar 1 | 19. Upper boom |
| 8. Pedestal | 20. Telescoping boom |
| 9. Lift cylinder | 21. Jib boom |
| 10. Lower boom 1 | 22. Self levelling bar 3 |
| 11. Valve box | 23. Jib boom cylinder |
| 12. Linkage piece 1 | 24. Controls box at platform |
| | 25. Platform |
| | 26. Platform self levelling cylinder |

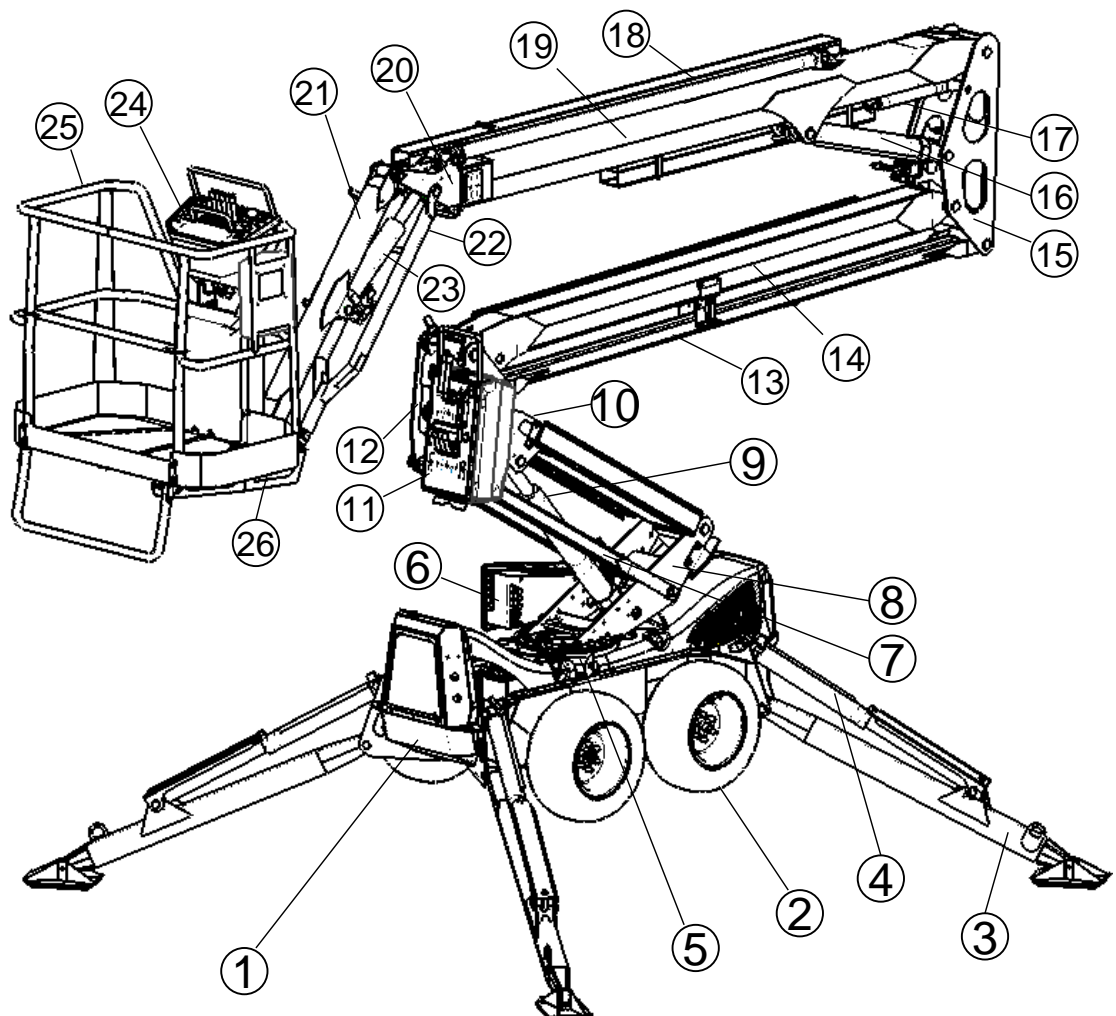

3. TECHNICAL SPECIFICATION, LEGUAN 160

Working height		15,9 m
Max. platform height		13,9 m
Max. outreach		6,7 m
Safe working load		200 kg
Transport length		5000 mm
Transport length without platform		4570 mm
Transport height,	23" wheels	2015 mm
	20" wheels	1980 mm
	Tracks	2010 mm
Width,	23x10.50-12 wheels	1240 mm
	23x8.50-12 wheels	1210 / 1040 mm
	20x8.00-10 wheels	1250 / 1020 mm
	Tracks	1290 mm
Platform dimensions, W x L, 2 persons		1300 x 750 mm
Platform rotation		± 45°
Slewing		360°
Gradeability		35%
Support dimensions (outrigger spread)		3292 x 3256 mm
Max. gradient of slope for set up		23% (13,3°)
Weight, depending on equipment		2100 - 2300 kg
Drive system		4WD or rubber tracks
Drive speed		1,4 km/h / 4 km/h
Lowest operating temperature		- 25° C
Starter battery / Electric system		12V
Sound power level at platform controls, L _{WA}		75 dB

3.1. Reach diagram

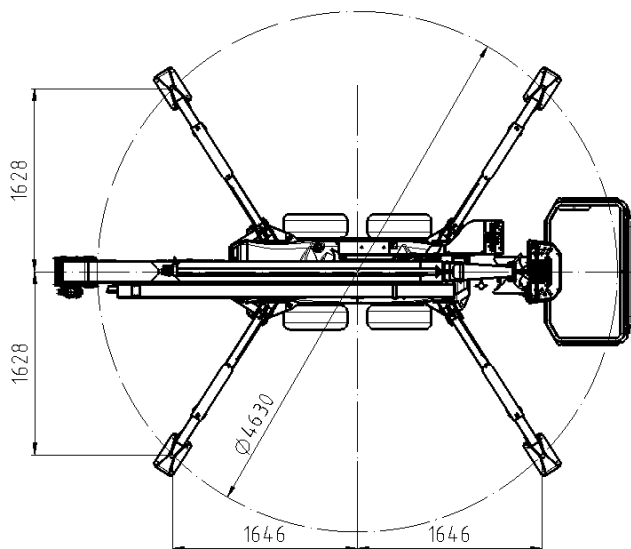
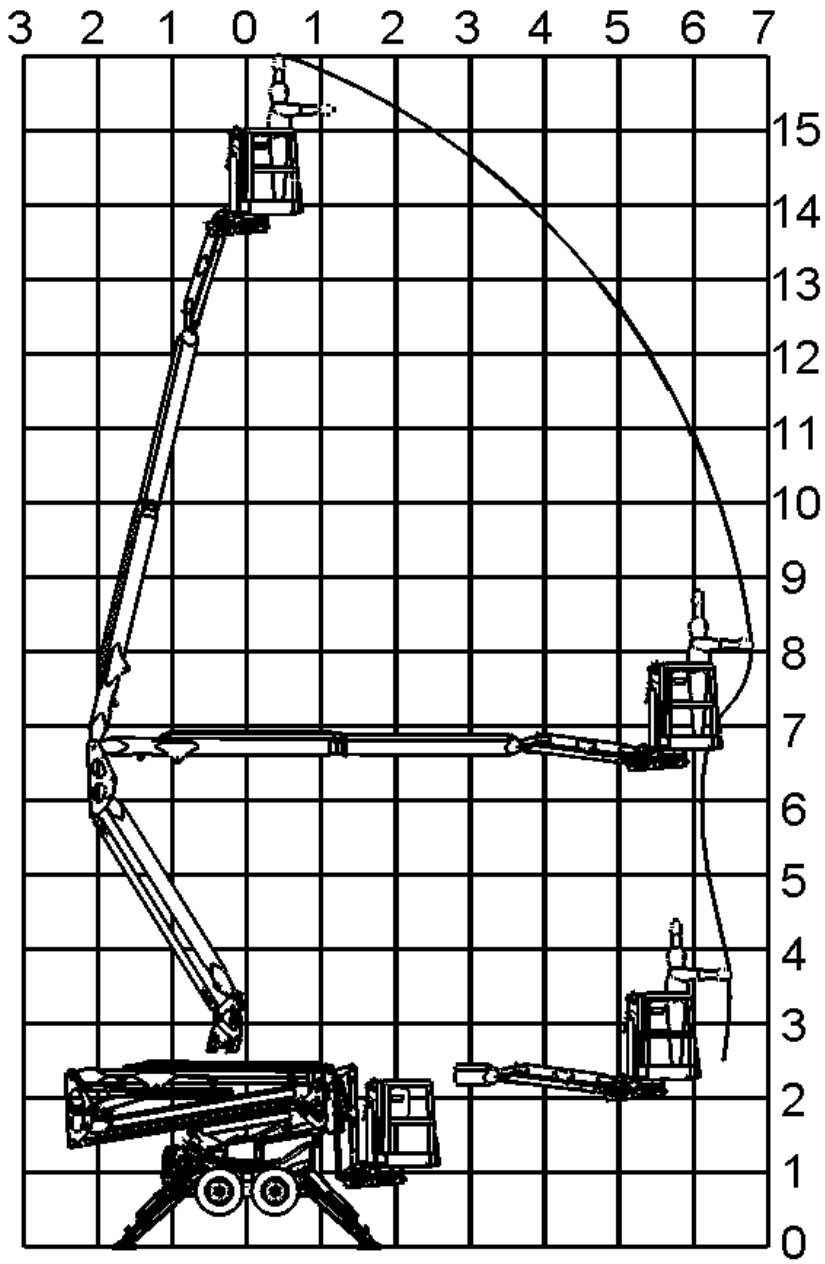

4. SIGNS AND STICKERS

1. Type plate and CE marking
2. Safe working load (SWL)
3. Max. horizontal force and wind speed
4. General user instructions
5. Daily inspection
6. Always use outriggers
7. Symbol stickers (pictograms) of controls
8. Emergency lowering
9. Residual current device
10. Voltage of electric motor
11. Max. support force
12. Distance from energized electric wires
13. Tie down points
14. Tyre pressure
15. LEGUAN 160 sticker

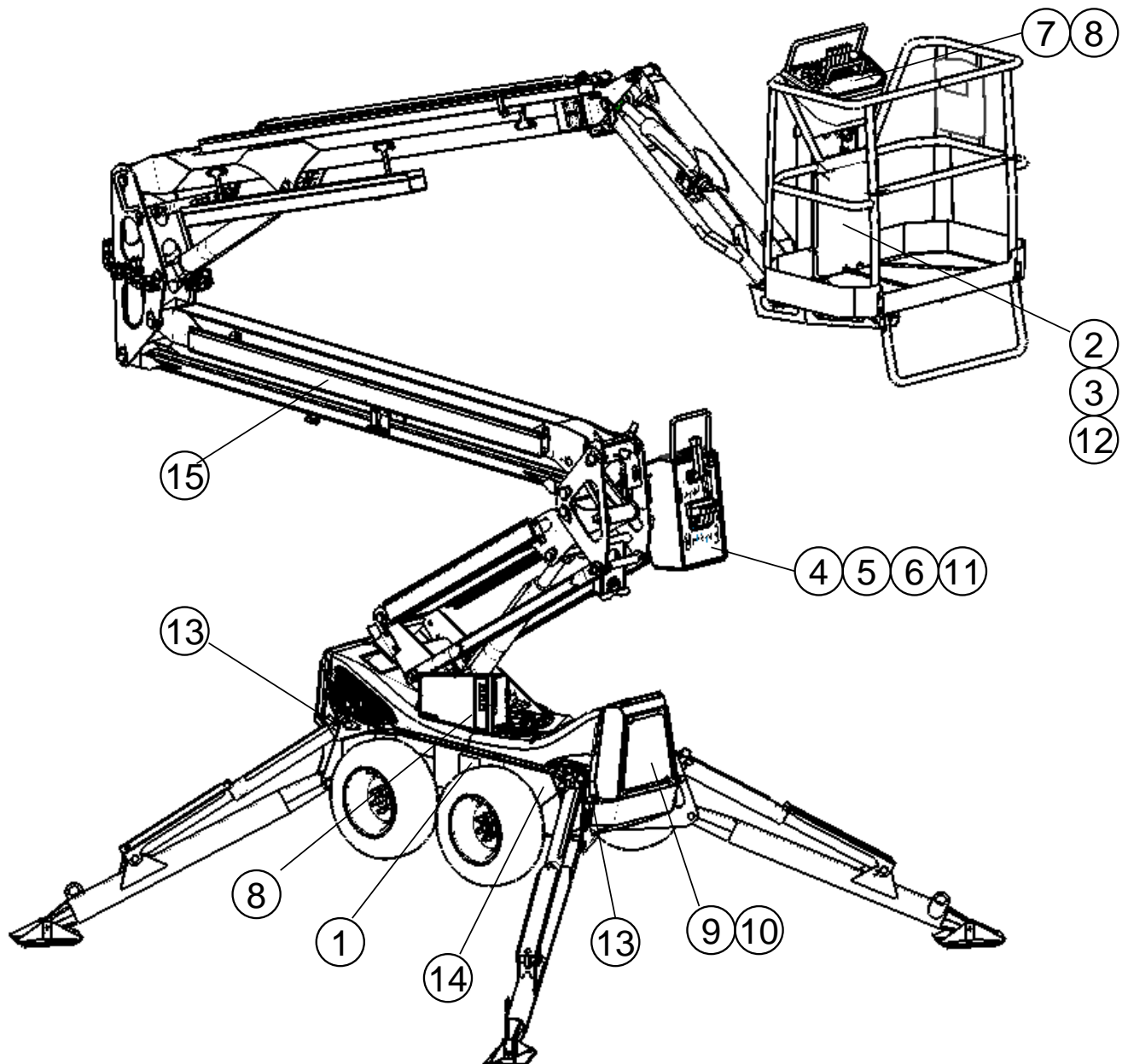

5. SAFETY INSTRUCTIONS

The operator must know and follow all safety instructions. The operator must receive sufficient instructions in order to be able to use the lift correctly and safely. This Operators Manual must always be kept in the box on the platform.

ATTENTION !

In order to prevent unpermitted use of the access platform, take the main battery disconnect key that is located on ground level and the engine ignition key, if fitted, with you after ending operation.

CAUTION! DANGER !



THE ACCESS PLATFORM IS NOT VOLTAGE INSULATED. NEVER USE IT NEAR ANY VOLTAGE CARRYING PARTS OR DEVICES. DO NOT DRIVE ANY PART OF THE ACCESS PLATFORM OR PLATFORM CLOSE TO UNINSULATED CABLES OR OTHER VOLTAGE CARRYING PARTS OR DEVICES.

WHEN WORKING WITH THE ACCESS PLATFORM THE OPERATOR(S) MUST ALWAYS WEAR CERTIFIED SAFETY HARNESS WHICH IS PROPERLY CONNECTED TO THE PLATFORM.

5.1 Before starting operation

- All warnings and labels must be read carefully.
- Only persons with min. 18 years of age are allowed to use the access platform. They must have received sufficient operating instructions.
- Operator must know all the functions of this access platform as well as the Safe Working Load, loading instructions and safety instructions.
- If there is heavy traffic in the working area, it must be fenced off widely enough and marked with a fence or with a line. Road traffic regulations must be followed as well.
- Make sure that there are no bystanders in the working area.
- Do not use faulty access platform. Inform about all faults and defects and make sure that they are repaired before starting operation.
- Follow check and service instructions and intervals.
- The operator must check this access platform visually at the beginning of each work shift. This check is necessary in order to make sure that the machine is all right before making the daily inspection prior to starting operation.
- If combustion engine is used indoors, make sure that the ventilation is sufficient.

5.2 Risk of tipping over



- Safe working load (200 kg), number of persons (2) and additional load on the platform must never be exceeded.
- When wind speed is equal to or greater than 12,5 m/s - 28 mph, the use of the access platform must be discontinued immediately and the platform must be lowered down to transport position.
- Ensure that the access platform is used on dry, solid, level ground only. The ground is solid enough if it can carry min. 3 kg/cm². On softer grounds use extra support plates under the outriggers (plate dimensions 400 x 400 mm).
- Do not use a ladder, chair, stool, scaffolding or by any other means try to increase reach capability of this access platform.
- In case the platform has got stuck or jammed, or it is too close to a building or a wall to be moved, do not try to release the platform by operating the controls. All persons must leave the platform first (with the help of a rescue service of fire brigade if necessary), only after that one can try to lower the platform by using the emergency lowering.
- Do not try to increase the area of the platform or the load. Increasing of the area exposed to wind will weaken the stability of the access platform.
- Weight must be equally distributed on the platform. Make sure that additional weight cannot shift on the platform.
- Do not drive on gradients that are steeper than the max. values given for this access platform and for the slope.
- Never use this access platform as a crane or an elevator. This access platform is intended for lifting of the max. allowed number of persons and additional load only.
- Check and make sure that all tyres are in good condition. If the tyres are air filled make sure that there is correct pressure in the tyres.
- In order to ensure the safe operation of this access platform the manufacturer has conducted approved tests for the **LEGUAN 160** in accordance with the standard EN280 +A2 : static stability test in accordance with paragraph 6.1.4.2.1 and dynamic overload tests in accordance with paragraph 6.1.4.3 of the EN280 +A2.

5.3 Risk of falling



- The operator(s) must always wear certified safety harnesses when operating this access platform. The harnesses must be connected to the fastening point at platform mounting bracket.
- Do not stretch or reach out over the handrails. Stand steadily on the platform floor.
- Keep platform floor clean.
- Always close the platform gate before starting operation.
- Do not drop or throw any material down from platform.
- It is not allowed to go to or step out from the platform when the booms are lifted.

5.4 Risk of collision



- Adjust the drive speed so that it is safe with regard to the ground conditions.
- The operator must follow all regulations concerning the use of safety equipment on the work site.
- Make sure that there are no overhead obstacles on the work site that could prohibit lifting of the platform, or objects that might cause a collision.
- Do not operate this access platform in the working area of another overhead lifting device or similar equipment that is moving, unless this lifting device is secured so that there is no risk of collision.
- Beware of crushing hazard when holding the handrail of the platform in an eventual collision situation.
- When operating the lift beware of eventual limited visibility and trapping hazard.

5.5 Risk of electric shock

- This access platform is not voltage insulated nor protected against contact with voltage carrying parts, or when approaching them.
- Do not touch the machine if it comes in contact with voltage carrying electric line.
- Persons on the platform or at ground level must not touch or operate the platform before power has been cut off from the electric line.
- During welding repairs, it is not allowed to use any part of this access platform as earth conductor.
- Do not use this access platform during thunderstorm or high winds.
- Leave clearance to electric lines taking into account movements of platform, movements of electric line, and high winds and gusts.

The minimum safety clearances to voltage carrying electric lines are shown in the following table. These clearances must be respected.

VOLTAGE	MIN. DISTANCE
0 – 1000V	2 m
1- 45 kV	3 m
110 kV	5 m
220 kV	5 m
400 kV	5 m

5.6 Risk of explosion / fire

- It is not allowed to start the motor/engine in a place where one can smell LPG, petrol, solvent or other flammable substance.
- Do not fill with fuel when the engine is running.
- Charge the battery only in places with sufficient ventilation, where there is no open fire or no works which could cause spark emissions (like welding).

5.7 Daily inspection before starting operation

- | | |
|-------------------------|----------------|
| - ground | - controls |
| - supports | - driving area |
| - horizontal levelling | - platform |
| - emergency stop button | - oil leakages |
| - emergency lowering | - working area |

ATTENTION! If you note faults or missing equipment on this access platform, do not put it into operation before the faults have been corrected. Never set the access platform up in a place where the ground may be too soft. Beware of soft grounds and potholes in particular.

6. CONTROLS AND SWITCHES

6.1 Controls at platform

The controls and indicators on the control panel at platform may be slightly different in different models. Indicators and switches that are marked as options are not mounted on all models.

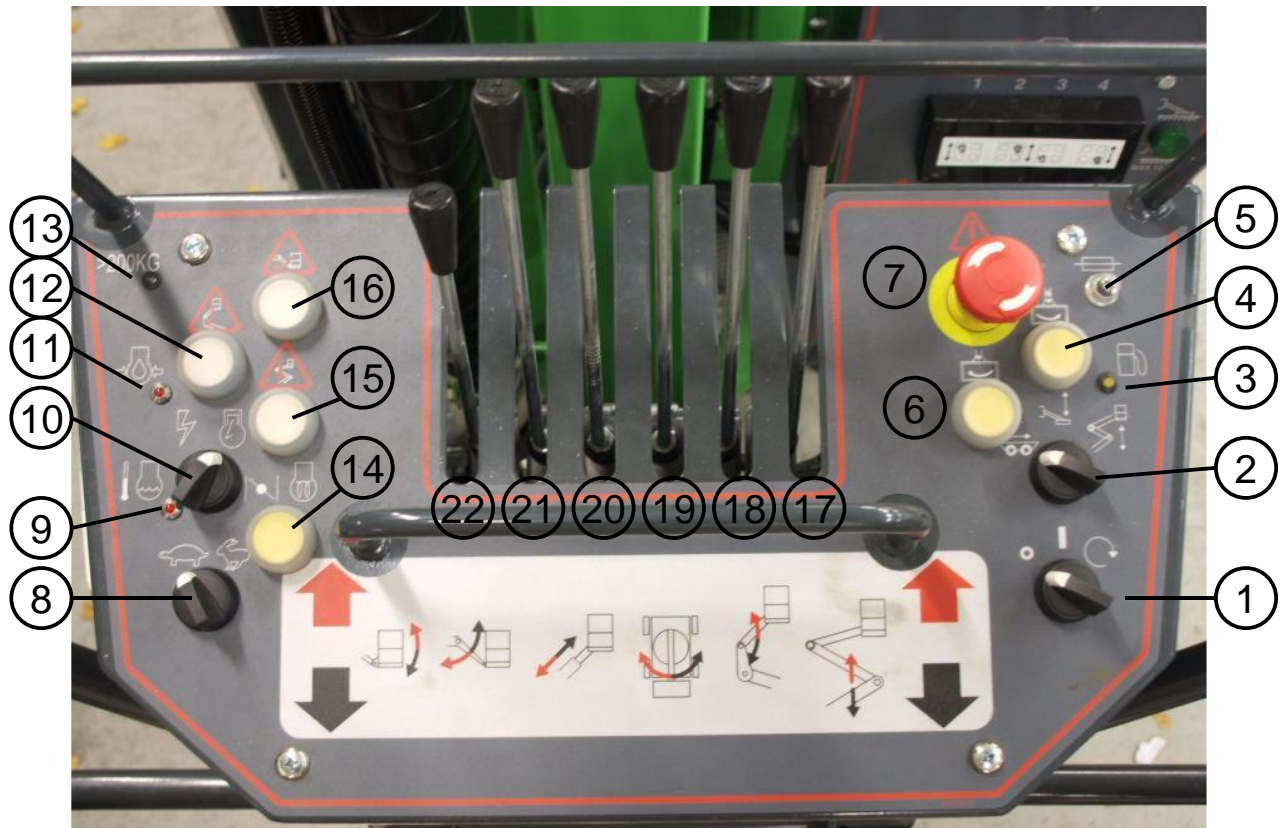

- | | |
|---|--|
| 1. Ignition switch: Stop - ON - Glow (diesel) – Start | 11. Engine oil pressure indicator (option) |
| 2. Function selector switch: Drive – Outrigger operation – Boom operation | 12. Emergency lowering, upper boom |
| 3. Fuel level indicator (option) | 13. Overload control indicator |
| 4. Platform rotation, to the right (option) | 14. Choke / Glow indicator |
| 5. Fuse, platform rotation (option) | 15. Emergency lowering, lower boom |
| 6. Platform rotation, to the left (option) | 16. Emergency lowering, jib boom |
| 7. EMERGENCY STOP switch | 17. Control lever, lower boom |
| 8. Drive speed area selector switch | 18. Control lever, upper boom |
| 9. Coolant level indicator (option) | 19. Control lever, slewing |
| 10. Selector switch of propelling: electric motor or combustion engine | 20. Control lever, telescope |
| | 21. Control lever, jib boom |
| | 22. Control lever, platform self levelling |

6.2 Controls at ground level

6.2.1 Battery disconnect switch at ground level

Battery disconnect switch connects and disconnects the circuit from the + line of the battery. When main current is switched off, all low voltage functions are cut off except for emergency lowering. DO NOT switch off the main current when the booms are not in transport position!

6.2.2 Controls on the control valve box at ground level

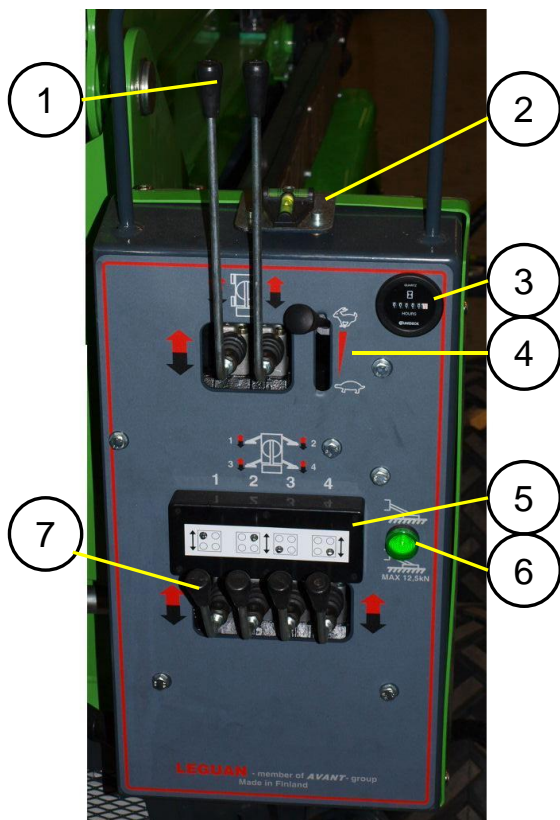

1. Control levers, drive
2. Water level
3. Hour meter
4. Hand throttle
5. Outrigger pressure indicators, red LEDs
6. Boom lifting indicator
7. Control levers, outriggers

6.2.3 Emergency lowering buttons at ground level



1. Emergency lowering, jib boom
2. Emergency lowering, upper boom
3. Emergency lowering, lower boom
4. Crank, manual emergency operation of slewing

6.2.4 230V - Connection and switches (Option)

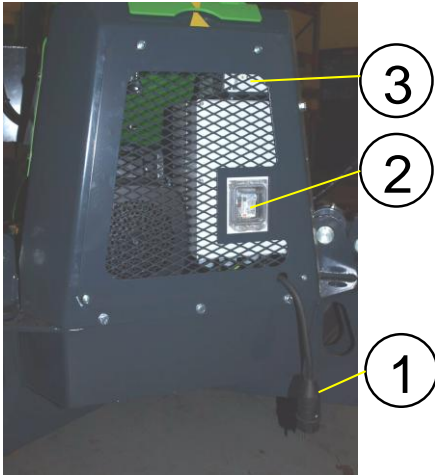

1. 230V 50Hz, 16A connecting cable
2. Switch of residual current device. The switch must be in "ON" position in order that any 230V device will work, including the 230V outlets. With the TEST button one can test the function of the residual current device, and also if there is 230V current coming from the network. If the residual current does not go off when pushing the TEST button, it is either defect or then there is no current coming from the network (the connecting cable must be connected of course).
3. Battery charger. There are two indicators on the charger which show the charge level of the battery: Yellow indicator on = low charge; Yellow and green indicator on = battery almost fully charged; Green indicator on = battery fully charged / trickle charge

6.2.4 Lower controls (Option)



1. Selector switch of lower / upper controls
2. Ignition switch: Stop – ON - Start
3. Overload control indicator
4. EMERGENCY STOP switch
5. Control lever, lower boom
6. Control lever, upper boom
7. Control lever, slewing
8. Control lever, telescope
9. Control lever, jib boom

Function of lower controls:

1. The ignition switch at platform must be turned to "ON" position.
2. Select with the selector key switch no. 1 either lower controls or upper controls at platform. The machine can be operated either with lower or upper controls, but not with both at the same time.
3. When lower controls are selected the engine/electric motor can be started and stopped with the ignition switch no. 2 at lower controls.
4. When the engine/motor is running the booms can be operated – except for platform self levelling – with the control levers of lower controls.

ATTENTION! The EMERGENCY STOP switch at lower controls works always, regardless of the position of the selector switch of lower/upper controls.

7. STARTING THE ENGINE / ELECTRIC MOTOR

Read carefully this Operators Manual and also the Operators Manual for the engine before starting operation. Read and understand all safety instructions before starting operation.

It is the operator's responsibility to follow all operating and safety instructions.

This access platform is destined for lifting of persons and additional load only. Lifting of materials is unsafe and not allowed.

If several persons are operating this machine during the same work shift, all of them must be trained and they must follow all operating and safety instructions.

1. Switch on the battery disconnect switch.
2. When using the electric motor connect the 230V cable and check also function of residual current device. With the TEST button you can also check that there comes 230V to the machine.
3. Make sure that the booms are down in transport position. If necessary, press on the emergency lowering buttons one by one.
4. Check emergency stop switch; release by turning the switch if it is switched on
5. Fasten safety harnesses on the fastening points at platform mounting bracket and close the gate.
6. Select desired propelling with the switch no. 10 at platform (electric motor/combustion engine, see page 14) and select slower drive speed.
7. If electric motor is selected, start the electric motor by turning the ignition switch to the "Start" position to the right.

Starting of combustion engine:

8. Adjust the hand throttle (lever no. 4, page 15) to about $\frac{3}{4}$ throttle.
9. If ambient temperature is below +5°C preheat the diesel engine in the "Glow" position of the ignition switch at the platform. When the switch is turned to "Glow" position the yellow indicator lights up. Preheat until the indicator goes off (if ambient temperature is very low this may take up to 20-25 seconds).
10. When the yellow indicator goes off start the engine by turning the ignition switch to the right to "Start" position.
11. When starting the petrol engine turn the ignition switch to the right to "Start" position and at the same press also on the choke button until the engine starts.
12. Once the engine has started reduce throttle to desired engine revs level.

ATTENTION! The engine must always be stopped with the ignition switch at platform, by turning the switch to the left to "Stop" position.

8. DRIVE CONTROL

ATTENTION! The machine can only be moved when the booms are down in transport position!

When driving with the machine special attention must be paid to the following things:

1. **Drive on solid and level grounds only**, with sufficient carrying capacity.
2. **Working materials and tools *must be fastened and secured*** against rolling and/or sliding.
3. **Safety harnesses must always be attached to the fastening points at platform mounting bracket** when the engine or electric motor is running.
4. Operate the control levers smoothly, avoid jerky movements.

Instructions for driving:

1. Start the engine and turn the function selector switch no. 2 at platform (see page 14) to "Drive" position.
2. Make sure that the drive speed area selector switch is in desired position. **Changing of drive speed area is not allowed when the machine is moving!**
3. Driving forward and backward happens by moving the levers of the drive control valve (see page 15). By pushing the left lever left side wheels turn forward; by pulling the lever left side wheels turn backward. Right side wheels turn in the same manner by pushing and pulling the right side lever.
4. Turning of the machine is based on the skid steer principle: When you want to turn the machine either to the right or to the left, push/pull the drive control lever on the inner curve side. By doing this the inner wheels brake and consequently the machine turns.

If you want to turn the machine on the spot, push one side control lever and pull the other side control lever to the extreme end position. The way the machine moves and turns depends also on ground conditions – start the driving carefully and at low speed.

Transmission of the LEGUAN 160 is hydrostatic. Each wheel is equipped with a hydraulic motor - the machine is four wheel drive. If the machine is equipped with rubber tracks there are two hydraulic motors in the track system.

ATTENTION! Learn how to drive with the machine at a low speed. Operate the drive control levers with ease in order to avoid abrupt and jerky movements. When driving pay special attention to stability and the dimensions, especially length, of the machine.

8.1. Defining the gradient of the slope

Measure the slope with a digital clinometer, or do as follows:

Take a water level, a straight piece of wood at least 1 m long, and a pocket tape measure.

Put the wood stick on the gradient. Put the water level on the lower edge of the stick and lift the stick until it is in horizontal position. Keep the stick level and measure the distance from the lower end of the stick to the ground. Divide the distance (height) by the length of the wood stick (distance) and multiply the result by 100.

Example:
 Wood stick length = 2 m
 Height = 0,5 m
 $(0,5 \div 2) \times 100 = 25 \%$ slope

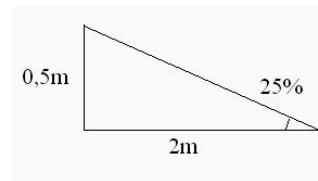

ATTENTION! When crossing slopes always drive up or down the slope, not sideways. If you have to drive sideways on a slope, lower the downhill side outriggers so that they are close to the ground. This prevents the machine from tipping over.

8.2. Crawler track chassis

General information and lifespan of rubber tracks

An access platform with skid steer chassis, equipped with crawler track chassis, offer many advantages compared with a machine on wheels. However, certain things regarding working and working environment must be taken into account with an access platform on tracks.

In order to secure the maximum life expectancy for the rubber tracks and crawler track chassis follow the instructions below.

The lifespan of the track system of an access platform on rubber tracks is heavily dependent on the working environment and the way of working. The operator can increase the lifespan by following the below mentioned operating and maintenance instructions. If the access platform is being used in terrains with stones or gravel, on demolition sites where there is concrete, or in an environment with scrap metal, the lifespan of the track system can be significantly reduced. Because of this damages on the tracks, track rollers or crawler track chassis, caused by operation in such environments, are not covered by warranty.

Nuts of the rear sprocket

It is important to check tightening of nuts on the rear sprocket (bigger track wheel) about 2 days after putting the access platform into operation. When driving with a new machine the parts in the track system adapt to each other and "find their place" so to say. Because of this it is possible that the nuts loosen during operation. Loose nuts can cause serious damage to the crawler track chassis.

- Tighten the nuts first to 120 Nm diagonally opposite
- After that retighten immediately to 140 Nm final torque diagonally opposite
- It is recommended to check tightness of nuts once a week

8.2.1 Instructions for working environment

In order to increase the lifespan of the track system avoid driving on the following terrains or work sites:

- **Environments with crushed stone, iron bars, scrap metal or similar recycling material.** Rubber tracks are not designed for this kind of environments.
- **Daily / continuous driving on asphalt or concrete.** Continuous operation on these surfaces will shorten the lifespan of rubber tracks.
- **Work sites with sharp objects, like broken stones or concrete waste.** This kind of sharp objects can cut or damage the rubber tracks permanently. Conditions which can damage tyres can also damage rubber tracks. Damaged tracks can normally not be repaired, they must be replaced. Warranty doesn't cover tracks that get damaged in this kind of conditions.
- **Work sites with corrosive substances (fuels, oil, salt or fertilizers).** Corrosive substances can oxidize the metal parts in rubber tracks. If such substances come in contact with the surface of the rubber track, the tracks must be flushed with water immediately after ending operation.

8.2.2 Operating instructions

- **Check track tension regularly.** Too loose tension can make tracks jump off the sprockets. Do not over-tension the tracks, because this causes big power loss and excessive wear on the sprockets and tracks.
- **Change turning direction as often as possible.** Turning continuously only in one direction will cause uneven wear of the sprocket and the rubber track.
- **Check condition of the track system regularly.** Excessive wear on the rollers, idlers, sprockets and bearings can damage the tracks.
- **Avoid driving sideways on a gradient.** Always drive the slopes straight up and down, and turn on flat even surface only. Continuous operation on uneven terrains or driving sideways on a gradient causes wear in the track guides and rollers and makes tracks jump off the sprockets.
- **Avoid continuous sharp turns.** By making wider and more gentle turns you can avoid unnecessary wear of the tracks and/or tracks jumping off the sprockets.
- **Avoid driving with one track on level surface and one track on a gradient.** Always drive on an even surface. If the tracks bend continuously from the inside or from the outside during operation, the metal structure of the tracks can break.

9. OPERATION OF THE OUTRIGGERS

Lifting of the booms without setting down the outriggers is never allowed!

Outriggers shall be driven down to support position as follows:

1. Make sure that the function selector switch no. 2 at platform (see page 14) is in outrigger position
2. Make sure that all four red LED indicators of outrigger pressure are lit, and that the green indicator (see page 15) is not lit. If the red LEDs are not lit, lift all four outrigger control levers so that the LEDs light up.
3. Deploy the outriggers down by pulling the levers of the control valve (see page 15). It is possible to deploy only one outrigger at the time but it is recommended to deploy two outriggers (front or rear) at the same time. Make sure that the ground under every outrigger is solid enough – put extra plates on the ground if necessary.
4. Drive the outriggers down on the ground firmly enough. They must be driven down so much **that all wheels lift off the ground !** (Usually it is not necessary to push the outriggers further unless it is necessary to reach higher). Make sure that the wheels do not touch the ground before starting to lift the booms.
5. When all outriggers are firmly on the ground and wheels lifted off the ground, check the horizontal position of the lift with the water level which is mounted on top of the control valve. **It is not allowed to lift the booms if the machine is not level!**
6. After the machine has been levelled correctly, the green indicator that allows lifting of the booms is lit and all four red LED indicators are not lit, turn the function selector switch immediately to boom lifting position. If one or more LED indicators are still lit, press sharply on all four outrigger control levers.

If the green indicator of boom lifting is lit when the outriggers are not correctly deployed, the operation of this access platform is not allowed! Contact nearest Leguan service!

10. OPERATION OF THE BOOMS

Before starting to lift the booms:

1. Make sure that all four outriggers are on solid ground, the machine has been levelled correctly and that the green indicator that allows lifting of the booms is lit. If the green indicator is not lit and one tries to lift the booms the engine/motor stops and will not start before the booms have been lowered down to transport position by using the emergency lowering buttons.
2. Turn the function selector switch no. 2 at platform to boom operation position.
3. Adjust the hand throttle to slightly more than idling.
4. The booms are operated with the control levers of the boom control valve at platform – or with the control levers of lower controls, if fitted.
5. **LEGUAN 160** is equipped with an overload control system which prevents boom movements in case the 200 kg safe working load is exceeded. Should this happen, there is an audible warning signal and an indicator lights up at the control panel. The booms can be operated again after the overload has been removed from the platform, and the ignition switch has been turned to "0" position – that is the motor/engine has been stopped and restarted.

ATTENTION! Always lift the lower booms first from transport support before operating other movements. When lowering the booms make sure to drive them straight down to transport supports.

Thanks to the fully hydraulic controls boom movements are very smooth, exact and stepless. Operate the control levers with ease and without hesitation – learn to operate the booms precisely.

Platform self levelling system keeps the bottom of the platform level automatically.

ATTENTION! If the level position of the platform must be adjusted – for instance in case the machine has not been used for a long time and the platform has tilted – operate the control lever of platform self levelling carefully, especially when the booms are up.

11. EMERGENCY LOWERING

If the power supply for some reason cuts off (e.g. no fuel or electricity cuts off, or connecting cable fails) the booms can be lowered as follows:

1. The lift is equipped with an electric emergency lowering system. There are emergency lowering buttons both on the platform and at ground level. By pushing the button the selected boom comes slowly down as long as the button is being pushed. Emergency lowering takes its power directly from the battery – it is not dependent on the position of the main switch. Emergency lowering valves are protected with a 10A fuse which is located in the connection box on the side at ground level.
2. Before lowering the booms to transport supports always make sure that they are properly aligned and going straight down to transport supports. If necessary, the booms can be rotated at the end of the slewing ring shaft either with a 22 mm key or with a socket wrench or with the crank that is located on top of the emergency lowering controls box at ground level. Switch off main current before rotating the booms

ATTENTION! Always remember to remove the tool after rotating the booms. Never rotate the slewing ring by hand when the engine/motor is running and the main current is on!

Always check function of emergency lowering before starting operation.

12. ENDING THE OPERATION

After ending operation:

1. Lower the booms down to transport position.
2. Lift the outriggers completely up to transport position.
3. Stop the engine/motor by turning the ignition switch to 0 position.
4. Remove safety harnesses from the platform and take them with you (harnesses must be kept in their place and in their box/package).
5. Move the main disconnect switch to horizontal position and take the key with you.
6. If the machine stays in a place where it can be connected to 230VAC mains current, it is recommended to connect it, in order to charge the battery (e.g. overnight).

ATTENTION! Prevent unauthorized use of the access platform!

13. TRANSPORTING INSTRUCTIONS

Lower the booms down to transport position and lift the outriggers completely up to transport position.

ATTENTION! Transporting of this access platform is allowed in its transport position only. No persons or materials are allowed to be transported on the platform.

The outriggers are equipped with lifting points from which the machine can be lifted if necessary. When lifting, it is advisable to use a lifting beam where the ropes are mounted, in order that the outriggers will not get damaged.

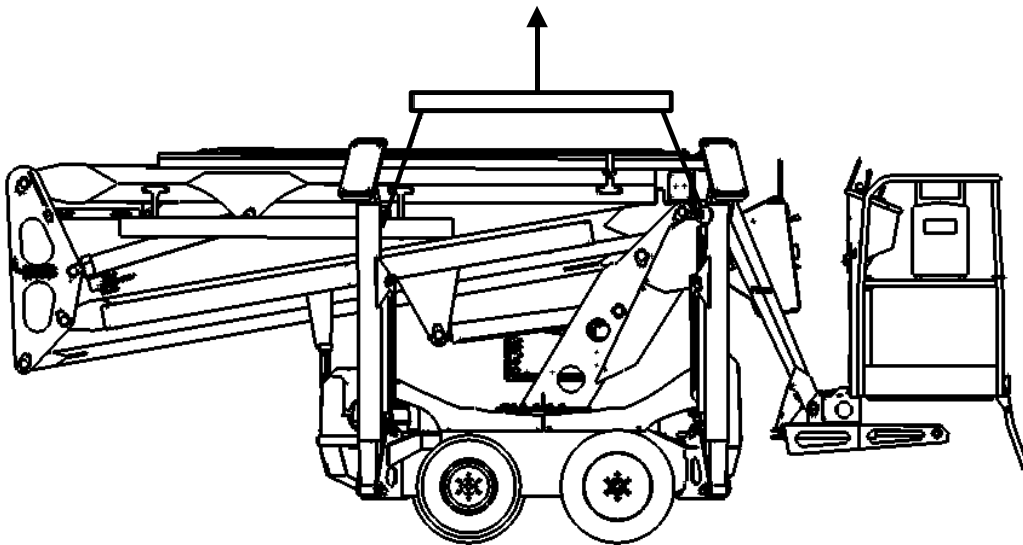

There is an automatic hydraulic brake in the rear axle which engages automatically when the engine/motor is not running.

If the machine is transported on a trailer or on a lorry or similar vehicle, it must be tied down properly. There are four tie-down points marked on the corners of the chassis which make it easy to tie down the machine. Always tie the machine down diagonally from every corner.

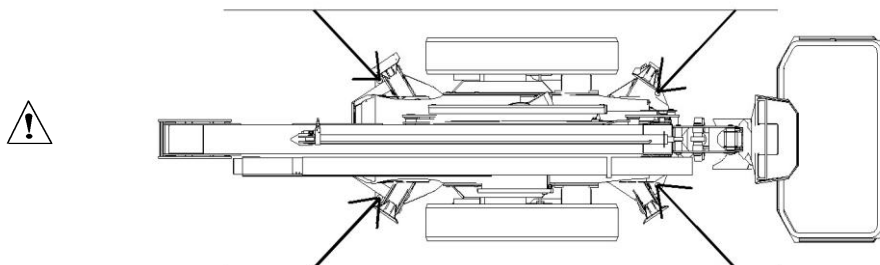

ATTENTION! It is not allowed to tie down the machine so that the ropes go over the booms. Only marked tie-down points can be used!

ATTENTION! Before longer transports close the fuel valve of the petrol engine in order that engine oil and petrol can not mix and cause misfiring of the engine.

14. SERVICE, MAINTENANCE AND INSPECTION INSTRUCTIONS

This access platform must be inspected once a year. The inspection can only be done by a qualified person. Persons who conduct periodical services shall familiarise themselves with the operation and technical features of this access platform before doing any service operations. All service and maintenance operations must be made in accordance with the instructions in this manual. If the access platform has not been used for a longer period of time, oil levels must be checked first and made sure that the machine functions correctly before starting operation.

14.1 General instructions

- It is not allowed to make any changes on the construction of the machine without written permission from the manufacturer.
- All defects that may have an effect on the safe use of this access platform must be repaired before starting operation.
- Only professional persons are allowed to open the covers and handle the electric etc. components. Risk of serious injury!
- Make sure that services are made in accordance with this Operators Manual and with the Service Manual of the engine manufacturer.
- Stop the engine before starting any service or inspection operation, DISCONNECT ALSO THE 230V MAINS CURRENT.
- Do not smoke during service and inspection operations.
- Keep the machine and especially the platform clean.
- Make sure that the operating instructions are complete, readable and in their place in the box at the platform.
- Make sure that all stickers are in their place and readable.

ATTENTION! All spare parts – especially electric components and sensors – must be original Leguan parts.

Always remember when handling the battery:

- Battery contains corrosive sulfuric acid – handle the battery with care! When handling the battery wear protective clothing and eyewear.
- Avoid contact with clothes or skin; if electrolyte gets on your skin or clothes flush with a lot of water.
- In case of contact with eyes, flush with a lot of water for at least 15 minutes and call a doctor immediately.
- Do not smoke when handling the battery.
- Do not touch the battery terminals or cables with tools that may cause spark emissions.
- In order to avoid spark emissions always disconnect the (-) cable first and connect it last.

Handling of fuel and oil products:

- Do not let any oil leak on the ground.
- Use oil qualities recommended by the manufacturer. Do not mix different oil types and/or brands with each other.
- When handling oil always wear appropriate protective equipment.
- Before refueling always stop the engine/electric motor and disconnect from mains current.
- Only use fuels recommended by the engine manufacturer. Do not mix any additives with the fuel.
- If fuel or oil gets into eyes, mouth or open wound, clean immediately with a lot of water or designated fluid and call a doctor.

Check hydraulic hoses and components only when the engine is stopped and with pressure released from the hydraulic system. Do not operate the machine if you have noticed faults or leaks in hydraulic system. Ejection of hydraulic fluid can cause burns or penetrate the skin and cause serious injuries. Consult a doctor immediately if hydraulic fluid penetrates your skin. Wash carefully with water and soap any body part that has come in contact with hydraulic oil. Hydraulic oil is also harmful to the environment – prevent oil leakages. Only use hydraulic oil type approved by the manufacturer.

Never handle pressurized hydraulic components, because in case of failure on a fitting or component ejection of high pressure hydraulic fluid can cause tipping over of the machine and serious injuries. Do not operate the machine if you have noticed a fault in the hydraulic system.



Check hydraulic hoses for eventual cracks and wear. Follow the wear of the hoses and stop operation if the outer layer of any hose has worn out. Check routing of the hoses, adjust the hose clamps if necessary in order to prevent chafing. Hydraulic hoses have finite service life and the expiration date is marked on the hoses. After that they have to be changed. If there are signs of oil leakage, put a piece of cardboard under the probable leakage place in order to find the leakage.

If you find a fault, operation of the access platform must be stopped immediately and the hose or the component must be replaced. Contact Leguan service.

14.2 Services and checks, maintenance schedule

Regarding the service of the engine see also engine manufacturer's Operators Manual = EM

CH = Check CL= Clean R = Replace A = Adjust F = First service at 50 h

Operation		day	month	100 h	200 h/12 month	400 h/24 month	1000 h
Engine oil, EM	FR	CH		R			
Engine oil filter	FR				R		
Air filter, EM			CH/CL		R		
Glow plug							CH
Valve clearance, EM							A
Fuel filter						R	
Fuel tank				CH			CL
Fastening of platform	F	CH					
Hydraulic oil							R
Hydraulic oil level			CH				
Hydraulic oil suction filter						CL	
Hydraulic oil filters	FR				R		
Battery			CH				
Coolant	FCH		CH			R	
Locking of bearings and pivot pins	FCH		CH				
Electric wires					CH		
Hydraulic fittings and hoses	F	CH					
Cylinders, load holding & check valves	F	CH					
Function of emergency lowering	F	CH					
Function of emergency stop circuit	F	CH					
Function of set up system	F	CH					
Hydraulic pressure adjustments	F				CH		
Function of control valves	F	CH					
Mounting of booms on the chassis			CH				
Condition of steel construction			CH				
Movement speeds of booms	F		CH		A		
Greasing of the machine			R				
Function of load control system	F			CH	A		
Level position of water level	F		CH				

Hydraulic oil type:

Statoil Hydraulic Oil 131,
(-45 – 65 °C. Vickers 104 C IP 2 81/80, FSD 8401)

Hydraulic system oil volume:

oil tank 35 l, complete system 55 l

Engine oil:

See engine manufacturer's manual

Grease:

Litium NLGI 2 grease (not MoS2), slewing ring with grease containing EP (extreme pressure) additive

Pressure settings of hydraulic system:

Main pressure 275 bar (3980 PSI),
outriggers 200 bar (2900 PSI), booms 235 bar (3410 PSI)

Tyre pressure:

20*8.00-10 grass profile 3.0 bar (43 PSI)
23*10.50-12 grass profile 3.0 bar (43 PSI)
23*10.50-12 TR profile 3.0 bar (43 PSI)

Wear pads on the telescopic boom must be checked every 5 years max.

Tightening torque of the M16 fastening bolts of the slewing ring is 210 Nm – torque must be checked once a year and bolts must be changed every 5 years.

Above mentioned service intervals are recommendations. If the operating conditions are very hard and/or the machine is in heavy duty use the service and change intervals must be shortened.

15. SERVICE INSTRUCTIONS

15.1 Greasing of the machine

Greasing of the machine is of utmost importance in order to prevent wear in joints. Most of the joints are service free - however the slewing ring must be greased in accordance with the maintenance schedule, using grease that contains EP (extreme pressure) additive. Outrigger bearings and articulation bearings in all hydraulic cylinders must be greased in accordance with the maintenance schedule.

15.2 Handling of fuel and refueling

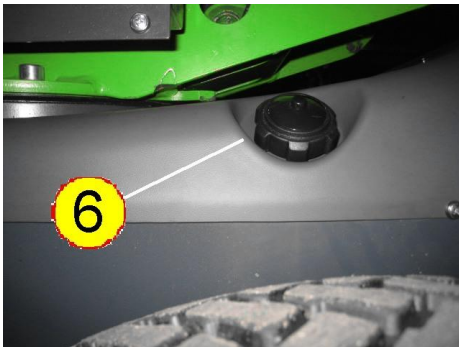

Check fuel level and refuel if necessary (fuel tank cap, no. 6). In diesel engine use DIESEL fuel only, see also Kubota Operators Manual. Use of other fuels is not allowed. Make sure not to let the fuel tank get empty. Should this happen, refuel and restart – the engine is fitted with automatic fuel bleeding. In petrol engine use fuel defined by the engine manufacturer in the engine Operators Manual.

15.3 Hydraulic oil and oil filter change

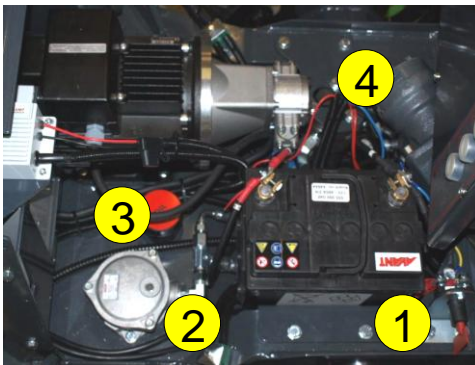

Hydraulic return oil filter is located on top of the hydraulic oil tank (no. 2) at the rear of the chassis. Replace the filter by removing the filter cap and replacing the filter cartridge. When changing hydraulic oil, the oil can be removed with a suction pump from the opening of breather cap (no 3), or by opening the drain plug. In both cases it is important to clean the magnetic drain plug.

Hydraulic pressure filter cartridge (no. 4) must be changed always when return filter is changed. Take off the filter bracket, lift up the filter, open and replace the filter cartridge.

15.4 Hydraulic oil level

Hydraulic oil level can be checked with the dipstick in the filler (no. 3). Oil level should be at the upper mark in the dipstick when the lift is in transport position (booms down on transport supports and outriggers completely up).

15.5 Battery check

In order to secure the starting and safe operation the battery must be checked regularly. Inspect and clean battery terminals regularly. Check also condition and fastening of battery cables and terminal insulators. Make sure that battery cables cannot chafe against any sharp edges. Check also condition and fastening of battery disconnect switch and cables.

ATTENTION! Always clean the battery before opening the caps so that dirt cannot get in the battery.

15.6 Check of set up outrigger control system



Always check the function of the set up outrigger control system when starting operation. If the red LED indicators don't light up, lift briefly all four outrigger control valve levers. If all red LEDs now light up and the green indicator doesn't, the set up system works correctly. After this the setting of outriggers can be done as usual.

ATTENTION! If the set up control system doesn't work correctly, it is not allowed to use this access platform, and the failure/defect must be repaired before starting operation.

15.7 Water level check

Correct position of the water level (on top of the control valve box at ground level) in relation to the upper surface of the slewing ring must be checked in accordance with the maintenance schedule, or if there is reason to believe that the position of the water level has changed:

Make sure that the booms are in transport position and put a water level on the slewing ring. Compare the position of this water level to the position of the water level on the control valve box. If the positions are different, adjust the water level on the valve box with the adjustment screws so that both levels are in the same position. Do the adjustment both lengthwise and sideways.

15.8 Adjustments in hydraulic system

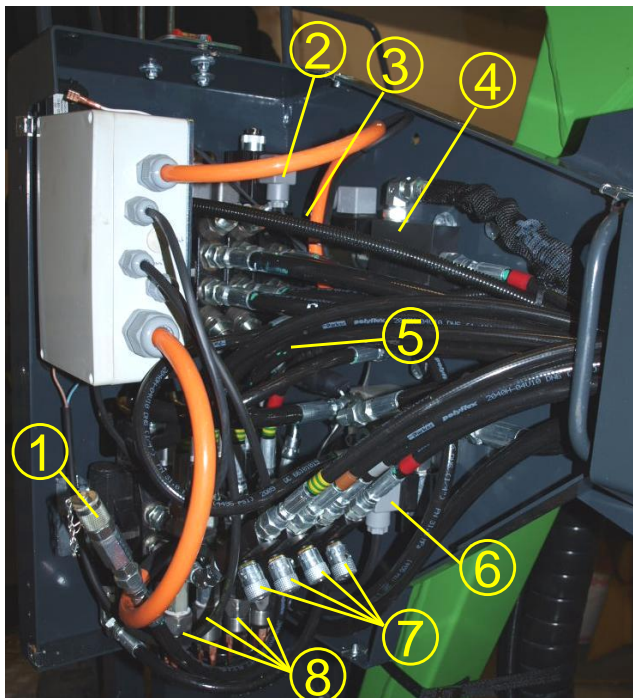

All settings of the hydraulic system have been made at the factory and normally there is no need to adjust them.

Picture left shows the valves in the valve box at ground level. The components are:

1. Hydraulic pressure check fitting. All hydraulic pressures are measured here.
2. Drive control valve, solenoid K98B (outriggers)
3. Drive control valve, main pressure adjustment 275 bar
4. Selector valve of lower controls K11S (option, lower controls)
5. Drive control valve, solenoid K98A (booms)
6. Tank line collector block, boom pressure solenoid K9
7. Outrigger lift speed adjustment
8. Outrigger pressure switches, PS1...PS4. Pressure is adjusted with the screw in the middle of the fitting. Adjustment 100 bar.

Hydraulic main pressure (no. 3 in picture) is adjusted from the pressure relief valve of the drive control valve. Outrigger pressure is adjusted from the pressure relief valve of the outrigger control valve. Boom pressures are adjusted from the boom control valve – in addition there are shock valves for boom slewing with which the pressure of the slewing hydraulic motor can be adjusted. Slewing speed is adjusted from the check valves on the side of the slewing hydraulic motor.

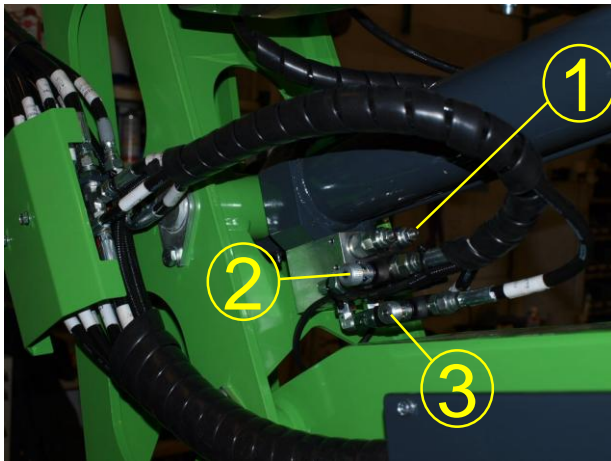

All cylinders – except for the self levelling "slave" cylinder – are equipped with load holding valves (no. 1 in the picture left), which prevent cylinder movements in case e.g. a hydraulic hose fails. When using emergency lowering of the booms, the electric solenoid valve in the cylinder (no. 2) opens and oil flows through the adjustable restrictor valve into the tank and the boom(s) come down. Boom lowering speed is adjusted with the restrictor valve. Adjustment of lift cylinder emergency lowering is on the side of the oil tank. On some cylinders the lowering speed is adjusted with check valves (no. 3).

15.9 Components in overload control system 

Overload control system has been set to correct values at the factory. Changing of the settings without permission and instructions from the manufacturer is strongly forbidden. RISK OF TIPPING OVER!

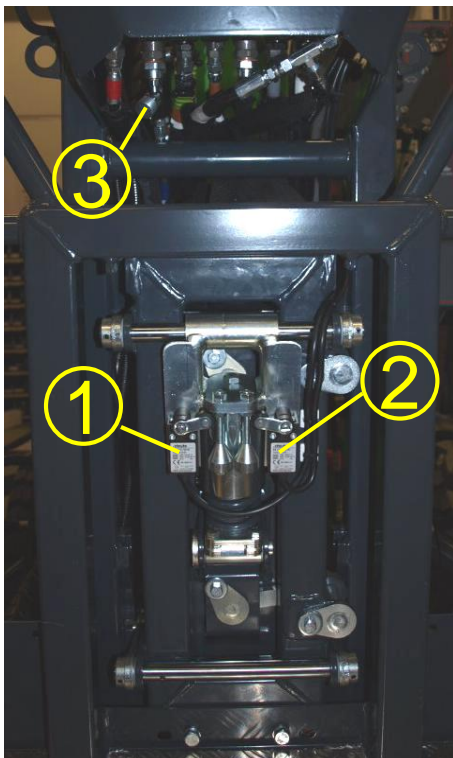

Overload control mechanism is located between the platform and platform mounting bracket, and is accessible by opening the cover plate on the platform. The platform is supported by a spring, located between limit switches S18 (no. 1) and S17 (no. 2). When the load on platform reaches 200 kg, limit switch S17 cuts off power supply to solenoid K98A in the drive control valve and to tank line collector block solenoid K9 and consequently prevents boom movements. If limit switch S17 for some reason doesn't work, limit switch S18 cuts off power supply to solenoid K98A in the drive control valve and prevents boom movements. In both cases there is an audible warning signal at the platform controls, and a red indicator starts to blink. Overload control system is reset by removing the overload from the platform and turning the ignition switch to "0" position.



NEVER EXCEED SAFE WORKING LOAD!

15.10 Check and adjustment of track tension

Check and adjust track tension with the outriggers deployed and tracks lifted off the ground. First track tension check and eventual adjustment shall be made after first hour of operation. After that track tension shall be checked, and adjusted if needed, once a week. Check also tightness of the bolts and nuts of the sprockets. See to it that the track tension is always correct. It has a direct effect on the wear of the tracks and eventual derailing of the tracks.

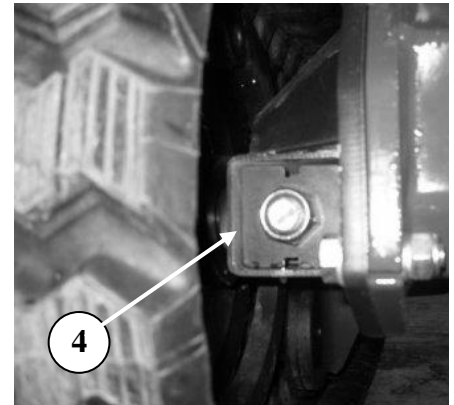
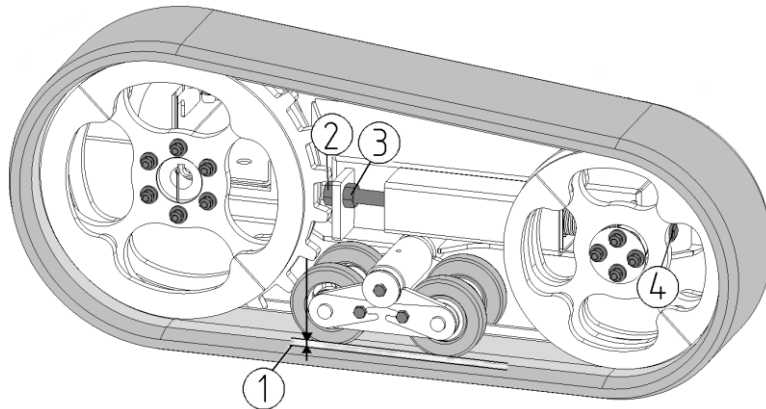

1. Lift the tracks off the ground by deploying the outriggers.
2. Move the tracks a bit forward and backward by moving the drive control levers. Check track tension as follows:
 - Way 1: Measure the slack between the track rollers and inside of the track, no. 1 in the picture above. The slack should be 10-30 mm. If it is more than 30 mm, tighten the track.
 - Way 2: Check if the front end plate no. 4 of the track tightening system can move freely. The end plate is located at the front of the track system, behind the front idler. If the plate moves easily, track tension is correct. If the plate is stuck, tighten the track.

Adjust track tension

Start adjusting by opening locking nut no. 2. After that tighten the tracks with the tightening nut no. 3 until the slack between the roller and inside of the track is about 10 mm, or until the end plate no. 4 moves freely. Finally retighten locking nut no. 2. The width across flats of the tightening and locking nuts is 36 mm (torque 350-400 N/m) . The nut at the end plate shall not be tightened when adjusting track tension.

16. REPAIR INSTRUCTIONS

16.1 Welding

All load carrying steel parts are manufactured from S420MC EN10149 sheet and S355J2H EN10219 tube.



Welding repairs are only allowed to be carried out by professional welders. When welding, use only methods and additives suited for above mentioned steel qualities.

SFS EN-ISO 5817 quality level D of imperfections in welding is suitable for all weldings, except for load carrying parts. Repair weldings in load carrying parts can be performed only by permission from the manufacturer.

ATTENTION! It is not allowed to change the construction and structure of this access platform without written permission from the manufacturer.

17. INSTRUCTIONS FOR TEMPORARY STORAGE

- The cable of the + pole of the battery should be disconnected, if the access platform is being stored for a period longer than 1 month
- The machine shall be covered and, if possible, stored inside or under roof in a place where unauthorized persons don't have access.
- Make sure that eventual leaks during storage will not cause waste water or similar environmental problems.

ATTENTION! See also engine manufacturer's instructions for the storage of the engine.

18. TROUBLESHOOTING

Following table shows eventual failures and malfunctions of the access platform and the ways how to repair them.

PROBLEM	REASON	CORRECTIVE ACTION
Engine/electric motor does not start when ignition switch is moved to START position. Engine and electric propelling	The booms are not properly down on the transport supports, and set up outrigger control system doesn't work.	Lower the booms down to transport supports by using emergency lowering. Select drive position with the function selector switch and start the engine/electric motor.
Combustion engine does not start when ignition switch is moved to START position. (See also engine manufacturer's Operators Manual).	Main Disconnect Switch is in "OFF" position. Petrol engine ignition switch is in "OFF" position Engine/electric motor selector switch at platform is in wrong position Emergency stop switch is pushed down Engine is cold. Fuel tank is empty. Empty start battery. Fuse inside the connection box is broken. The fuses are at the end of the terminal base.	Move to ON position. Move ignition switch to "ON" position Move to correct position Release emergency stop by turning it counterclockwise Preheat. Refill. Charge by connecting to 230V or change battery if necessary. Replace fuse.
Combustion engine does not start when ignition switch is moved to START position. (See also engine manufacturer's Operators Manual).	Faulty contacts in electric wires. Start switch is broken.	Check wires and terminals; and voltages with a voltage meter. Replace switch.

PROBLEM	REASON	CORRECTIVE ACTION
Electric motor does not start when ignition switch is moved to START position.	<p>Mains 230V cable is not connected to network.</p> <p>Engine/electric motor selector switch at platform is in engine position.</p> <p>Emergency stop switch is pushed down</p> <p>Battery Disconnect Switch is in "OFF" position.</p> <p>Empty start battery.</p> <p>Fuse inside the connection box is broken. The fuses are at the end of the terminal base.</p>	<p>Connect 230V mains, min. 16A wall socket fuse. Make sure that the socket is electrified.</p> <p>Move switch to electric motor position</p> <p>Release emergency stop by turning it counterclockwise</p> <p>Move to ON position.</p> <p>Charge by connecting the cable to 230V mains, or change battery if necessary.</p> <p>Replace fuse – if the fuse blows again, find out the reason.</p>
Electric motor stops suddenly during operation.	<p>Power failure.</p> <p>Emergency stop button accidentally pushed down</p> <p>Electric motor thermal overload relay (F1) in connection box has gone off.</p> <p>Connection fault in mains or 12V wiring.</p>	<p>Lower the booms by using the emergency lowering. Check that there is current in mains.</p> <p>Release emergency stop and restart.</p> <p>Wait for approx. 2 min. and start the motor – the relay will return to ON automatically. Find out the reason for overload.</p> <p>Check voltages and wirings.</p>
Movements don't work even though the engine/electric motor is running.	<p>Function selector switch at platform in wrong position.</p> <p>Failure in hydraulic system – e.g. hydraulic pump broken</p> <p>Overload on platform.</p>	<p>Turn the switch to correct position.</p> <p>Check hydraulic pressure . If there is no pressure check function of hydraulic pump and the coupling between engine and pump.</p> <p>Remove overload.</p>
Engine/electric motor stops when booms are lifted from transport support.	<p>Outriggers are not correctly deployed down to support position – green indicator lamp is not lit.</p>	<p>Lower the booms down to transport supports with emergency lowering, restart the engine/motor and deploy the outriggers properly so that the green indicator lights up.</p>

PROBLEM	REASON	CORRECTIVE ACTION
<p>Boom(s) come down by itself.</p>	<p>Dirt in load control valve or faulty valve.</p> <p>Dirt in emergency lowering valve or faulty valve.</p> <p>Emergency lowering valve(s) don't work when emergency lowering button is pushed.</p> <p>Lift cylinder seals faulty.</p>	<p>Clean valve with compressed air, if that doesn't help change valve.</p> <p>Clean valve with compressed air, if that doesn't help change valve.</p> <p>Check emergency lowering fuse, if all right check also emergency lowering valve(s) separately.</p> <p>Change lift cylinder seals.</p>
<p>Outrigger gives in.</p>	<p>Make sure that the ground doesn't give in.</p> <p>Air in outrigger cylinder(s).</p> <p>Dirt in outrigger cylinder check valve.</p> <p>Faulty check valve.</p> <p>Faulty outrigger cylinder seals.</p>	<p>Put extra support plates under the outriggers or move the machine to another place.</p> <p>Drive outriggers up and down a couple of times.</p> <p>Clean valve with compressed air.</p> <p>Change valve.</p> <p>Change outrigger cylinder seals.</p>
<p>Platform tilts backward by itself when booms are down on transport supports.</p>	<p>Air in hydraulic system.</p> <p>Dirt in load control valve of self levelling cylinder or faulty valve.</p> <p>Faulty self levelling cylinder seals.</p>	<p>Start the engine/motor, drive the platform to extreme end positions by using the lever no. 22 (see page 14). If this doesn't help, do the air bleeding of the platform self levelling system (there are bleeding screws in the self levelling cylinders).</p> <p>Clean valve with compressed air. If that doesn't help, change the valve.</p> <p>Change cylinder seals.</p>

18. SERVICES MADE

It is advisable to write down all service operations that are included in the periodical service. All services that have been made during the warranty period must be noted on the list below, otherwise the manufacturer's warranty will expire. The service operations mentioned in the maintenance schedule on page 27 shall be noted as follows: FIRST SERVICE, 1 MONTH SERVICE, 6 MONTHS SERVICE etc.

Date	Operating hours	Remarks / Information
1. _____	_____	_____
2. _____	_____	_____
3. _____	_____	_____
4. _____	_____	_____
5. _____	_____	_____
6. _____	_____	_____
7. _____	_____	_____
8. _____	_____	_____
9. _____	_____	_____
10. _____	_____	_____
11. _____	_____	_____
12. _____	_____	_____
13. _____	_____	_____
14. _____	_____	_____