

**NOTE!** These instructions should be considered only as a quick reference and they do not replace the operating instructions of your device.

Before using the device, please read the operating instructions and make sure you understand them and the warnings within.

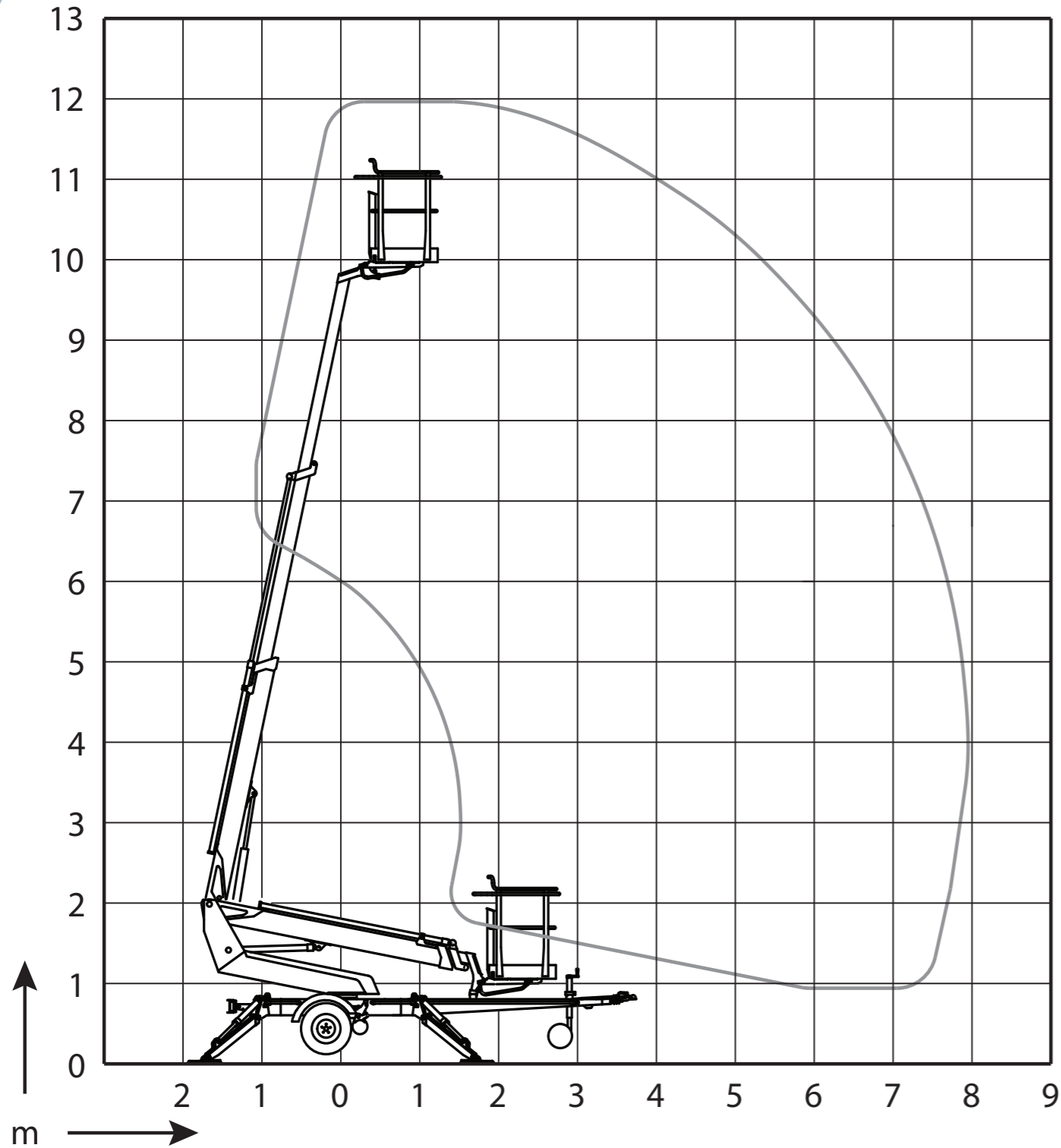

	120T	120TN	120TB
Max. allowed load on platform	120 kg	120 kg	130 kg
Transport height	1.95 m	2.05 m	1.95 m
Transport width	1.72 m	1.53/0.88 m	1.72 m
Support width	3.15/3.55 m	3.6/3.9 m	3.15/3.55 m
Weight	1,285 kg	1,355 kg	1,360 kg

## LIFT FUNCTIONS

Boom rotation: unlimited

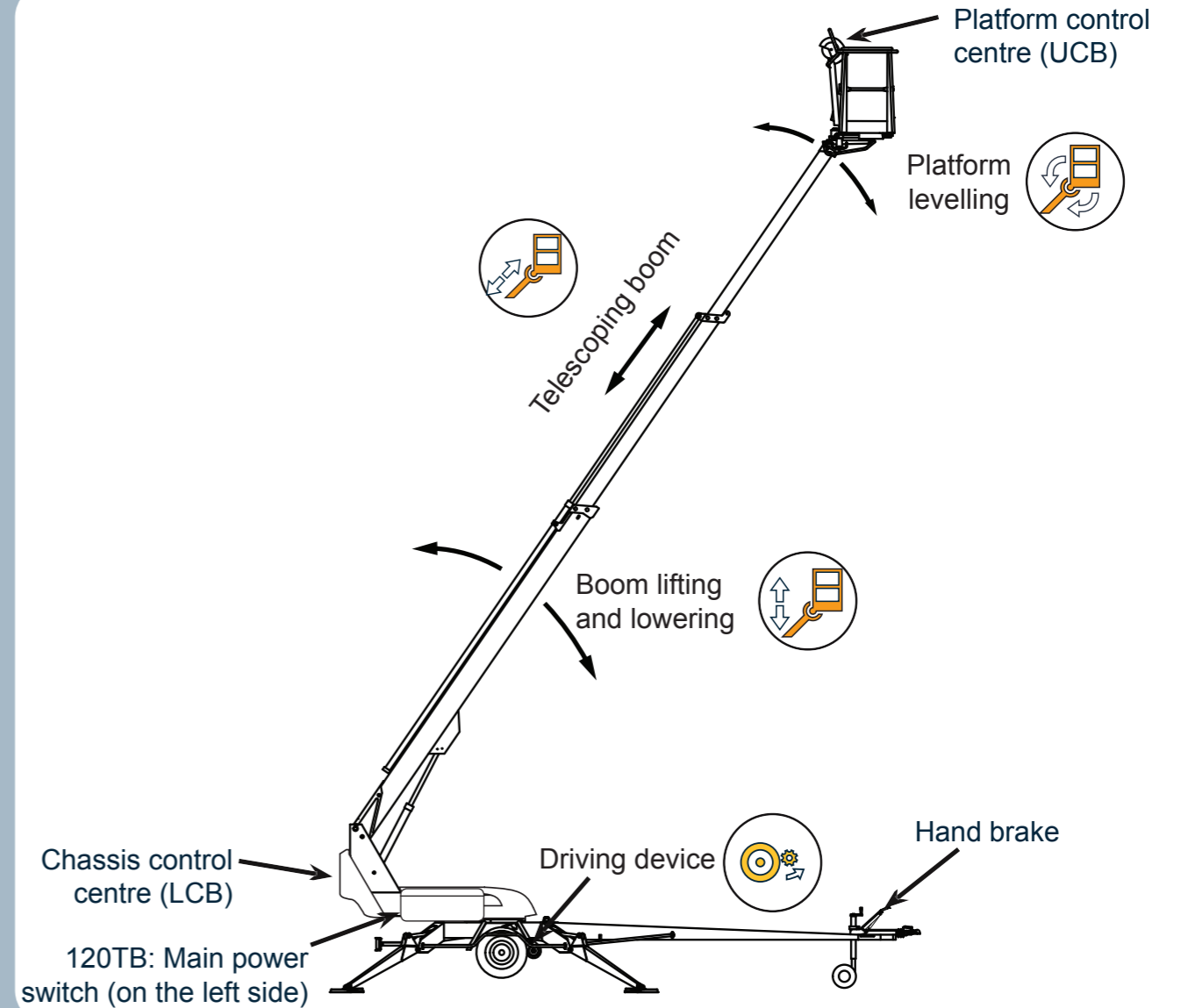
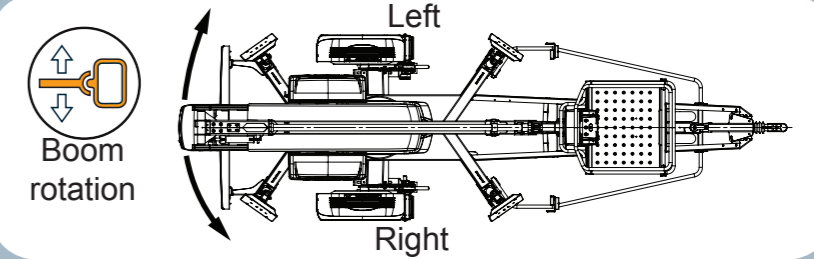

## DAILY INSPECTION

- Check the condition of the chassis, boom and platform
- Check that the tyres are inflated and there are no signs of damage
- Check the condition and operation of the lights
- Check the hydraulic hoses, pipes and connections and the hydraulic fluid level
- Test the safety limit switches
- Test the sound signal, emergency descent and emergency stop
- Check that all labels and signs are in place, intact and legible
- Check that the operating instructions are included and legible.

## STAY SAFE WHILE WORKING



Safety functions:

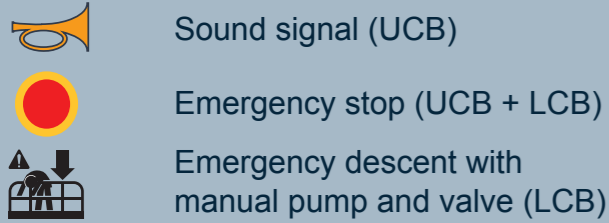

- This quick guide does not replace the operating instructions of the device. Read the operating instructions prior to use
- The operator must be at least 18 years of age
- The use of a faulty lift is strictly forbidden
- Never use the lift in temperatures below  $-20^{\circ}\text{C}$  or at wind speeds over 12.5 m/s
- Never use the lift as a crane
- Make sure the work area is clear
- Never exceed the maximum allowed load on the platform
- Never load the platform from above
- The maximum allowed lateral load is 200 N

## POWER SOURCES

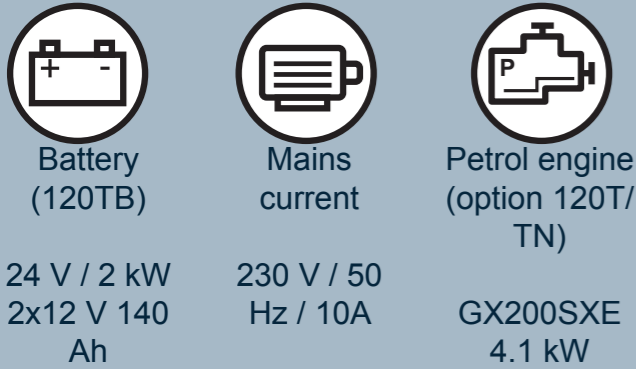

### Considerations for power sources:

- If the lift is connected to mains current, the power unit will not start
- When using mains current, the maximum power cable length is 25 metres (2.5 mm<sup>2</sup> cable), fuse: 10 A.
- Recharge the batteries at the end of the day. Storing uncharged batteries reduces their life.
- Operating temperature affects battery capacity.
- If the engine does not start, make sure none of the emergency stop buttons are pressed down.

## TOWING AND USING THE DRIVING DEVICE WITH THE LIFT IN THE TRANSPORT POSITION

Move the device only in its transport position, with the support outriggers completely retracted.

- Boom lowered on the boom support
- Control device covers closed
- Support outriggers completely retracted
- No items on the platform or chassis
- Check that the electrical cable has been disconnected or is sufficiently long

### Towing the lift

- Ensure that the axle has been widened (120TN)
- Connect the ball-coupling and wire
- Connect the electrical cable and test the lights
- Release the parking brake
- Lift the jockey wheel up
- Make sure the driving device is not engaged

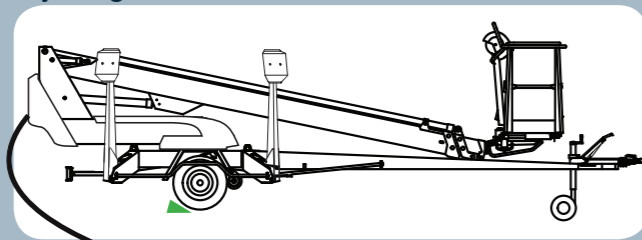
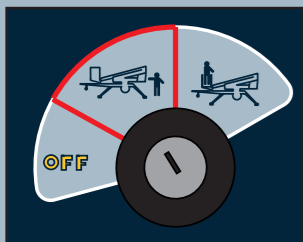

### Driving with the driving device

- Set the selector to its "chassis control centre" position
- Engage the driving device rollers
- Release the parking brake
- Use the controls to drive the device
- Keep an eye on the power supply cable and obstructions along the way

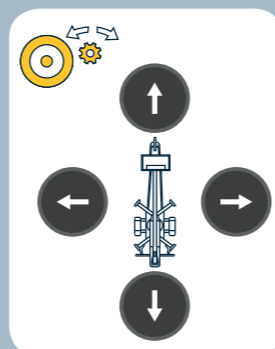
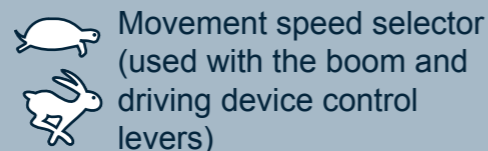

## OPERATING AND SUPPORTING THE LIFT FROM THE CHASSIS CONTROL CENTRE

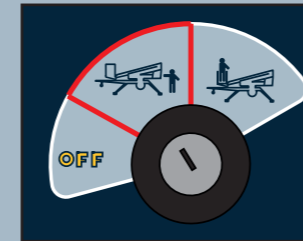

Indicators 120T/TB:

- The outriggers are engaged and the boom can be used.

Indicators 120TN:

- Support outriggers at support width.
- The outriggers are engaged.

Once the support outriggers are engaged, the boom can be moved from the chassis control centre.

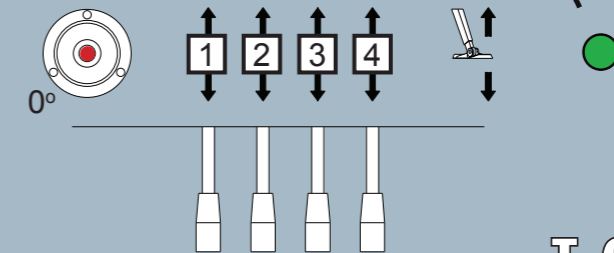
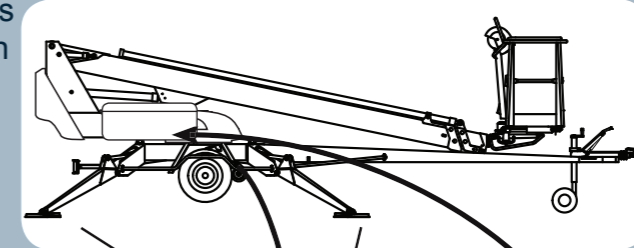
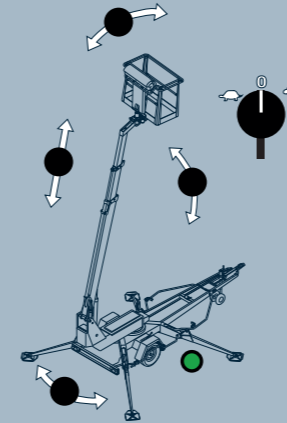

NOTE! The support outriggers cannot be moved when the boom is not on its support.

### Support

- Make sure the base is sufficiently solid and level. If required, use additional plates.
- Lower the front outriggers
- Lower the back outriggers
- Level the chassis. The air bubble in the spirit level should be inside the inner ring.
- Check that the wheels are completely off the ground

### Max. support force on the outriggers:

- 9,500 N (970 kg)

120TB Outrigger motor start switch. When other movements are used, the engine starts automatically when a movement speed is selected.

The start and stop buttons of the 120T/TN are located in the LCB control centre.

## OPERATION FROM THE PLATFORM CONTROL CENTRE

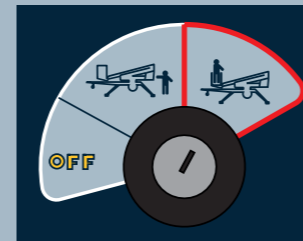

Before use

- Perform daily maintenance
- Make sure the device is stable and the chassis is level
- Test the emergency descent and stop functions
- Check the work area

Symbols in the control devices:

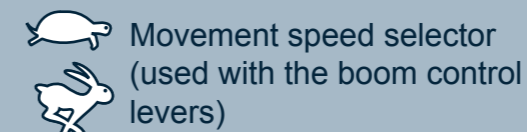
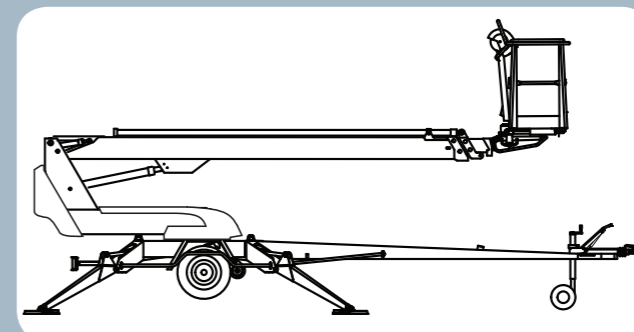
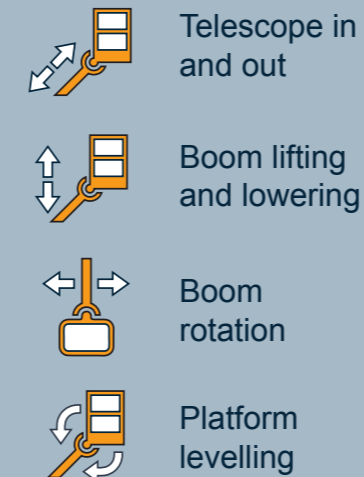

NOTE! If the support outriggers are not firmly engaged, all boom movements are disabled

### During use

- Do not exceed the maximum permitted load on the lift
- Use a safety harness
- Monitor the danger zone around the lift
- Beware of high-voltage cables and lines
- Do not climb onto the platform railing
- Do not drop items from the platform

### After use

- Drive the lift to its transport position
- Turn the selector switch to the OFF position
- Turn off the main power switch (120TB)
- Close and lock the covers of the control centres
- Disconnect the lift from the mains supply